



CORPORATION OF THE CITY OF VERNON

FINANCE COMMITTEE

THURSDAY, NOVEMBER 28, 2019

1:30 p.m. - KALAMALKA LAKE ROOM

AGENDA - REVISED

1. **ADOPTION OF AGENDA**

2. **ADOPTION OF MINUTES**

August 12, 2019 (Pg. 3)

3. **NEW BUSINESS:**

a) Council Discretionary Grant Applications - October 31st, 2019 intake

- Application Overview (Pg. 6)
- Council Discretionary Grant Policy (Pg. 12)

	APPLICANT	AMOUNT REQUESTED	Page #
1.	BC Ballooning Association	\$3,218	17
2.	Buoyant Buddies North Okanagan Dragon Boat Society	\$504	26
3.	Canadian Mental Health Association	\$10,000	36
4.	Dollywood Foundation of Canada	\$9,033	67
5.	Elks Lodge	\$10,000	81
6.	Independent Living Vernon	\$4,458	111
7.	Learning Disabilities Association – Vernon Chapter	\$4,000	129
8.	Literacy Society of the North Okanagan	\$5,000	145
9.	North Okanagan Cycling Society	\$5,000	155
10.	North Okanagan Gymnastics Society	\$24,938	166
11.	Okanagan Association of Classical Music Enthusiasts	\$6,000	194
12.	Okanagan Landing Community Association	\$7,383	213
13.	Schubert Centre	\$5,000	228
14.	Sovereign Lake Nordic Club	\$20,000	248
15.	Upper Room Mission	\$10,376	265
16.	Vernon Concert Band	\$800	279
17.	Vernon Homeless Outreach Team Association	\$2,500	294

Finance Committee Agenda – November 28, 2019

18.	Vernon Paddling Centre Society	\$1,406	310
19.	Vernon Pickleball	\$3,000	322
20.	Vernon Ski Club	\$5,000	338
21.	Vernon Youth Triathlon Society	\$3,696	352

4. **Quarter 3 Variance Analysis** (attached)

5. **NEXT MEETING:**

a) The next meeting date to be announced.

6. **ADJOURNMENT**



THE CORPORATION OF THE CITY OF VERNON

MINUTES OF THE FINANCE COMMITTEE HELD MONDAY, AUGUST 12, 2019

PRESENT: VOTING
Mayor Cumming
Councillor Mund

ABSENT: Councillor Gares

STAFF: Cindy Barker, Manager, Revenue Services
Aaron Stuart, Manager, Financial Planning & Reporting
Janice Nicol, Legislative Committee Clerk

ORDER The meeting was called to order at 1:04 p.m.

**ADOPTION OF
AGENDA** Moved by Mayor Cumming, seconded by Councillor Mund:

THAT the agenda for the Monday, August 12, 2019 meeting of the Finance Committee be adopted.

CARRIED.

**ADOPTION OF
MINUTES** Moved by Mayor Mund, seconded by Councillor Mund;

THAT the minutes of the Finance Committee meeting held June 27, 2019 be adopted.

CARRIED.

NEW BUSINESS

**TAX EXEMPTION
APPLICATIONS:
JUNE 1 – JULY 15
INTAKE**

The Manager, Revenue Services provided an overview on the updates to the tax exemption applications. The following points were noted:

- Habitat for Humanity has applied for 100% tax exemption. It was noted that Habitat remains on title only until the family meet criteria and title is then transferred to the family. BC Assessment has no way to do a partial exemption.
- Recommendation is for a one year tax exemption only.

- Exemptions are looked at on an annual basis and will be phased in over three years - meaning, if approved for a 100% exemption, first year 33%, next year 67%, following year 100%.
- Current tax exemption applications take effect for the year 2020.
- Vernon Book Volunteer Society – BC Assessment is assessing this organization as a Class 6.
- North Okanagan Valley Gleaners Society is also classified as a Class 6, is looking into making application to BC Assessment for a non-profit classification Class 08.

Moved by Mayor Cumming, seconded by Councillor Mund:

THAT the Finance Committee recommends that Council approves the percentage of tax exemption per classification for 2020 remain the same as 2019 namely as follows:

Social Service services	100%
Cultural and educational services	75%
Recreational services	50%

AND FURTHER, that the following properties making new application be granted 100% tax exemption, to be phased in over a three year period:

1. Habitat for Humanity Okanagan: #5, 4100 25th Avenue
2. Vernon Book Volunteers Society: #35, 100 Kalamalka Lake Road

AND FURTHER, that the following property making new application be granted 20% tax exemption, to be phased in over a three year period:

1. North Okanagan Valley Gleaners Society: 4405 29th Street

AND FURTHER, that the following property making new application be denied exemption:

1. North Valley Gymnastics Society: 4700 31st Street

Moved by Mayor Cumming, seconded by Councillor Mund:

THAT the Finance Committee **amends** the motion as follows:

THAT the Finance Committee recommends that Council approves the percentage of tax exemption per classification for 2020 remain the same as 2019 namely as follows:

Social Service services	100%
Cultural and educational services	75%
Recreational services	50%

AND FURTHER, that the following properties making new application be granted 100% tax exemption, to be phased in over a three year period:

1. Habitat for Humanity Okanagan: #5, 4100 25th Avenue
2. Vernon Book Volunteers Society: #35, 100 Kalamalka Lake Road

AND FURTHER, that the following property making new application be granted 20% tax exemption **to be applied in full in the first year and not be subject to the three year phase in period:**

1. North Okanagan Valley Gleaners Society: 4405 29th Street

AND FURTHER, that the following property making new application be denied exemption:

1. North Valley Gymnastics Society: 4700 31st Street

CARRIED.

DATE AND TIME OF NEXT MEETING

The next Finance Committee meeting is to be announced.

ADJOURNMENT

The Finance Committee meeting adjourned at 1:27 p.m.

CERTIFIED CORRECT:

Chair

Council Discretionary Grant Applications - October 2019 Intake

Count	Organization	Organization Overview	Purpose of Grant	Amount Requested	Amount Recommended	Reason for Denial for Council Resolution
1	BC Ballooning Association	Host a three day competitive festival that coincides with the Vernon Winter Carnival. Festival brings 10 to 15 pilots to showcase their skills.	To provide accommodation to the pilots that are volunteer time to participate and provide a briefing room and outdoor park area.	\$ 3,218		
2	Buoyant Buddies North Okanagan Dragon boat Society	Mission is to raise breast cancer awareness in our community and demonstrate that women who are living with the disease can lead active lives. Aim to improve the physical and psychological well-being of people with breast cancer.	4 lifejackets from innerspace watersports for new members joining.	\$ 504		
3	Canadian Mental Health Association	Dedicated to promoting mental wellness in the community. Enabling individuals, groups, and communities to increase control over, and to enhance their mental health.	To continue and expand our vital early intervention and prevention initiatives with Vernon youth.	\$ 10,000		
4	Dollywood Foundation of Canada	Dolly Parton's Imagination Library sends one book every month to the child's home from birth to age 5. The books are for all children, regardless of income and at no cost to the children or families.	For the first year, the program would need \$8,421 for the books and \$612 for 1,000 registration brochures. 5 year projected funding summary provided in application.	\$ 9,033		
5	Elks Lodge	Offer weekly recreation activities and dinner for community members. Monthly dances and performances are held at the lodge. Vernon elks are actively involved in community events.	Purchase a new piece of kitchen equipment, a meat slicer and replacement of tables.	\$ 10,000		

Council Discretionary Grant Applications - October 2019 Intake

Count	Organization	Organization Overview	Purpose of Grant	Amount Requested	Amount Recommended	Reason for Denial for Council Resolution
6	Independent Vernon Living	Resource centre for people with a variety of disabilities. Mission is to create sustainable community links, to work for societal change, and to remove barriers so that people with disabilities have the opportunity to reach their full potential.	To purchase 2 laptops and docking stations to assist staff with an accessible and reliable computer workstation when they are working with consumers one on one. Laptops provide the portability needed when staff are running programs or need to move offices to better accommodate the needs of consumers.	\$ 4,458		
7	Learning Disabilities Association - Vernon Chapter	Purpose is to advance the education, general-well being and support of children, youth and adults with average and above average intelligence who have severe learning difficulty processing, retaining and or retrieving sensory information.	\$2000 for supported tutoring bursaries for 4 students January to April \$1000 Rent \$1000 Support Materials In order to receive the support at no charge, parents apply for a tutoring bursary for their child.	\$ 4,000		
8	Literacy Society of the North Okanagan	Works with the community partners to provide literacy support for children and adults. Help to fill identified gaps and to address the learning and literacy needs in the community. A steering committee has formed and developed a strategy to address financial literacy gaps among youth.	The funds would be used to build the foundation of a local data-base of financial literacy resources and compile them as a one-stop source for local service providers. This includes research, outreach in the community. A candidate would be hired that would benefit from this work experience.	\$ 5,000		

Council Discretionary Grant Applications - October 2019 Intake

Count	Organization	Organization Overview	Purpose of Grant	Amount Requested	Amount Recommended	Reason for Denial for Council Resolution
9	North Okanagan Cycling Society	Mission is to create positive trail experiences for mountain bikers in the North Okanagan. Society works collaboratively with its membership, local and provincial governments and the community to develop and protect bike trails that is safe and enjoyed by a variety of different stakeholders.	Assist with funding and completion of a brand new professional built mountain bike trail within Kalamalka Provincial Park.	\$ 5,000		
10	North Okanagan Gymnastics Society	Dedicated to promoting the health and physical fitness of the community. NVGS provides programs uniquely designed to make each participant feel welcome and comfortable without regard to ability or fitness level.	Assistance to purchase/ replacement the gym equipment list. The list includes the most urgent needs. Any amount up to \$24,938.	\$ 24,938		
11	Okanagan Association of Classical Music Enthusiasts	To fill the gap that exists in the region when all local classical music organizations are on hiatus from early June until October and classical music performers and audiences have no outlet for playing or experiencing this type of music.	Help to provide free concerts and workshops for the community as part of the Vernon Proms' 2020. Expected to be attended by 1500+ audience. The grant will cover the rental fees for the venues, production costs and fees for professional artists.	\$ 6,000		

Council Discretionary Grant Applications - October 2019 Intake

Count	Organization	Organization Overview	Purpose of Grant	Amount Requested	Amount Recommended	Reason for Denial for Council Resolution
12	Okanagan Landing Community Association	To promote recreational, educational and cultural activities in the Okanagan Landing and District area; and to provide suitable buildings and grounds for the furtherance of such objectives.	Priority 1: Paddlewheel Hall Roadside Bulletin Sign to post events (\$1,630) Priority 2: Historical Wall Murals to emphasize cultural heritage (\$2,760) & Station House Museum Signs (\$827) Priority 3: Paddlewheel Hall Pergoia Sign to increase awareness, emphasize heritage(\$1,600), Paddlewheel Hall road & lakeside signs (\$566)	\$ 7,383		
13	Schubert Centre	A social and recreational "hotspot" for seniors since 1984. Staff and volunteers diligently uphold the United Nations principles for Older Person resolution, which states that seniors have the right to dignity, care, independence, participation, and self-fulfillment in society.	To replace the flooring and furnishings in the offices. The flooring in the rest of the facility has been updated over the last few years however the offices have not been in over 15 years.	\$ 5,000		
14	Sovereign Lake Nordic Club	Canadas largest cross-country ski club with more than 1800 members. Provides affordable winter sports for the Vernon community.	Support the club host the 2020 Nordic Ski Nationals at Sovereign Lake March 25-April 2, 2020. Estimated attendance is approx. 650-800 athletes plus 400 coaches. Grant will be for rental of tents and trailers to serve as shelters for ski waxing and servicing.	\$ 20,000		

Council Discretionary Grant Applications - October 2019 Intake

Count	Organization	Organization Overview	Purpose of Grant	Amount Requested	Amount Recommended	Reason for Denial for Council Resolution
15	Upper Room Mission	Provides emergency services by means of food and basic needs to homeless and vulnerable individuals and families in our community. The main goal is to express love and care for the underprivileged in our community. We seek to meet their physical, emotional and spiritual needs.	Re-launch "Loads of Love-Laundry Services" which offers free laundry services in a safe inclusive environment to those in need. One of our washing machines is no longer working and our other one is almost dead. Some of the funds will be used to purchase new machines (\$6,276). Folding table, chair and hampers (\$2,100), Laundry soap and dryer sheets (\$2,000).	\$ 10,376		
16	Vernon Concert Band	To provide a venue for people of all ages and abilities to get together and play in a concert band and to share that love of music with others by playing concerts and providing music for community events.	To cover some of the operating expenses that allow the band to practise and perform. For example, we require liability insurance to rent space to practise at Seaton School as well to perform concerts at such venues at Polson Park.	\$ 800		
17	Vernon Homeless Outreach Team Association	Offers compassion to those living on the streets in Vernon BC and to let them know that someone does care.	Use the funds for supplying carts with food and essentials.	\$ 2,500		
18	Vernon Paddling Centre Society	Devoted to the promotion of safe and skillful paddling. A club of independent paddlers who enjoy outrigger canoeing and other paddling sports.	To cover equipment purchases, the duo-flo stabilizers will allow us to modify 2 custom built wheelchair paddle boards and a kayak so that we can safely take our users out on the water. They are easy to assemble and add to our equipment and would enhance our ability to expand programs.	\$ 1,406		

Council Discretionary Grant Applications - October 2019 Intake

Count	Organization	Organization Overview	Purpose of Grant	Amount Requested	Amount Recommended	Reason for Denial for Council Resolution
19	Vernon Pickleball	To promote the development and growth of all aspects of the game of pickleball - social, recreational and competitive - for individuals of all ages and abilities in Greater Vernon	To acquire and install security cameras at the Marshall Fields pickleball facility. Estimate of \$4,000.	\$ 3,000		
20	Vernon Ski Club	Programs prepare athlete for competition in Slalom, giant Slalom, Super and downhill alpine disciplines. The club is lead by 100% volunteer parents and only coaches are compensated. Provides the ski swap and races to the community.	New race timing equipment - wireless, modern timing technology designed to accurately measure the time from when wand is activated in start gate to breach of laser at finish. BC Gaming grant is funding the other 50% of equipment.	\$ 5,000		
21	Vernon Youth Triathlon Society	Supports youth triathlons and multi-sport initiatives in the Greater Vernon area. The society was formed to ensure the sustainability of the annual youth triathlon event and multi-sport and triathlon opportunities for youth in Vernon.	The new permit requirements requires the society to rent stand alone fencing for the event. In addition to the fence cost, the society requests; 1. City cover the permitting costs for our event. 2. The City provide us with 2 RCMP officers for the morning of the event. 3. The City assist us with some site preparation at Kin Beach prior to our event and clean up.	\$ 3,696		
TOTAL REQUESTED			21	\$ 141,312		
				TOTAL RECOMMENDED	\$ -	



THE CORPORATION OF THE CITY OF VERNON
 3400 – 30th Street, Vernon, B.C. V1T 5E6
 Telephone: (250) 545-1361 FAX: (250) 545-4048
 website: www.vernon.ca

Corporate Policy

Section:	Finance	
Sub-Section:		
Title:	Council Discretionary Grant Policy	

RELATED POLICIES

Number	Title

APPROVALS

POLICY APPROVAL:	AMENDMENT APPROVAL:	SECTION AMENDED
Approved by: <i>"Wayne Lippert"</i> Mayor Date: November 13, 2007	Amendment Approved by: <i>"Wayne Lippert"</i> Mayor Date: June 9, 2008	Updated Sec. 1.3© to include "excluding tax exemptions."
	Amendment Approved by: <i>"Rob Sawatzky"</i> Mayor Date: November 26, 2012	"Remove clause noting that unspent funds in one fiscal year are rolled over to the next year."
	Amendment Approved by: <i>"Rob Sawatzky"</i>	"Amend intake periods, remove application form, and perform various

POSTED TO CITY OF VERNON WEBSITE

	Mayor Date: July 15, 2013	housekeeping updates and changes."
	Amendment Approved by: "Akbal Mund" Mayor Date: March 12, 2018	"Amended paragraph under Policy. Amended Capital Expenditures, Intake Period, Project under Definitions and added Program. Amended 1.2 (d) and (e) and 2.2, 2.2.1 and 3.1 (e) Removed last sentence"

POLICY

The City supports the enhancement and preservation of a positive quality of life for all its residents. One means of achieving this goal is through the provision of grants to organizations that contribute to the general interest and advantage of the City.

The awarding of grants is solely within Council's discretion; Council may deny any and all grant requests.

This policy is in effect subject to the continuance of ongoing annual funding.

Organizations requesting \$25,000 in a single year must submit, at their expense, audited financial statements to the City.

DEFINITIONS

Application means the documents listed in Section 2.1

Application Deadline means the 30th day of April and the 31st day of October.

Capital Expenditure means providing an asset in the City of Vernon that is significant and is of lasting benefit.

Community Based means a non-restricted membership group or organization:
 (a) whose practices are consistent with the City's Strategic Directions; and
 (b) who provide program(s), project(s) or capital expenditure(s) which positively and directly impact the City or its residents.

POSTED TO CITY OF VERNON WEBSITE

Intake Period means that applications will be accepted April 1 to April 30 up to 4:00pm and October 1 to October 31 up to 4:00pm, or if City Hall is closed on the due date, the next working day that City Hall is open up to 4:00 pm.

Project means a one-time event.

Program means an ongoing initiative by an organization. Funding preference will be given to startup programs.

Regional Funding means a funding source from surrounding communities or the regional district.

Resident means an individual who resides in the City.

PROCEDURES

1.0 *Eligibility for Grants*

- 1.1 An organization wishing to be considered for a discretionary grant will have to submit an application.
- 1.2 Each year, the City may award discretionary grants to organizations for the purpose of providing funding for a program, project or capital expenditure. An organization must meet the following criteria in order to qualify for a grant:
 - (a) The organization must be a non-profit organization or registered society;
 - (b) The organization must be Community Based;
 - (c) The organization is providing a service which is not provided by any other group or organization within the City or which is provided for in another municipality and is used by Residents.
 - (d) The organization may only submit one application per calendar year.
- 1.3 An organization is not eligible for a grant and the request will be denied if the grant:
 - (a) Is for retroactive funding or to cover a deficit.
- 1.4 Preference will be given to organizations who are not receiving local government funding such as:
 - (a) Regional funding
 - (b) Grants or other assistance from the City of Vernon, excluding tax exemptions.

2.0 Application Process

- 2.1 The organization must submit the following documents which form the application to apply for a grant:
- (a) A signed, completed application form;
 - (b) The most recent set of financial statements;
 - (c) The minutes of the most recent annual general meeting;
 - (d) A list of the members of the executive (including positions held, address and contact numbers);
 - (e) Confirmation of registered society status.
 - (f) A profile and history of the organization and its accomplishments.

2.1.1 Incomplete applications will not be considered.

- 2.2 The organization must submit the application to the Director of Financial Services, at Vernon City Hall no later than 4:00 pm on the application date(s), or if City Hall is closed on that day, no later than 4:00pm on the next working day that City Hall is open.

- 2.2.1 Applications for funding will be made on a semi-annual basis for those applications received between the intake periods of April 1 to April 30 4:00pm and October 1 to October 31, 4:00 pm each year, or if City Hall is closed on the 30th of April or the 31st of October, no later than 4:00 pm on the next working day that City Hall is open.

An application received before or after the application deadline will be returned to the applicant.

- 2.3 The Finance Division will:
- (a) Review all applications to ensure policy compliance; and
 - (b) Forward the applications to the Finance Committee for consideration and recommendation to City Council.
 - (c) Where funds have been exhausted for the current fiscal year the Director of Financial Services will advise the applicant by letter, and forward a copy of the notification to Mayor and Council.

3.0 Council Consideration

- 3.1 The Finance Committee will consider the following factors when making recommendations to Council as to which organizations it will support or deny a grant:
- (a) The extent to which an application demonstrates that there is need in the community;
 - (b) The extent to which the profile and history of the organization and its accomplishments and organization's goals and objectives are supportive of, or align with the City's Strategic Directions;

POSTED TO CITY OF VERNON WEBSITE

- (c) The degree to which the grant will support the enhancement of a positive quality of life for all City Residents;
- (d) The extent to which the organization has obtained other sources of funding (e.g. Federal or Provincial Government funding, corporate sponsorships, fundraising campaigns, etc.);
- (e) The availability of funds budgeted for discretionary grants;
- (f) The need(s) of the organization requesting funding;
- (g) The degree of demonstrated economic development, environmental stewardship or social benefit that may be generated by the award of a Council Discretionary Grant.



The Corporation of the City of Vernon

COUNCIL DISCRETIONARY GRANT APPLICATION FORM

IMPORTANT: The deadline for Council Discretionary Grant Applications are semi-annual being April 30 and October 31 each calendar year.

Applications will only be accepted during the intake periods of April 1 - April 30 and October 1 to October 31. Applications must be submitted to the Director of Financial Services no later than 4:00pm on the application deadline (April 30th and October 31st), if City Hall is closed that day, on the next working day that City Hall is open.

Applicants may run the risk of grant funding being depleted if waiting to apply until the October intake deadline.

If grant applications are received after the cut off periods they will be returned to the applicant and must be submitted at the next intake period.

Please note: Incomplete applications will not be considered

ORGANIZATION INFORMATION

NAME OF ORGANIZATION APPLYING FOR COUNCIL DISCRETIONARY GRANT:	British Columbia Ballooning Association (B.C.B.A.)
CONTACT PERSON:	Lori Carey
ORGANIZATION MAILING ADDRESS:	[REDACTED]
BUSINESS PHONE:	[REDACTED]
EMAIL ADDRESS:	[REDACTED]
REGISTERED NON PROFIT SOCIETY INCORPORATION NUMBER (required):	5007141

"Personal information contained on this form is collected under the *Freedom of Information and Protection of Privacy Act* and will be used only for the purposes of responding to your request".

City Hall Address: 3400 30th Street, Vernon BC, V1T 5E6
 Inquiries: 250-545-1361
 Web: www.vernon.ca

City Hall Address: 3400 30th Street, Vernon BC, V1T 5E6
Inquiries: 250-545-1361
Web: www.vernon.ca

PLEASE IDENTIFY THE STEPS YOUR ORGANIZATION HAS TAKEN TO ACQUIRE GRANTS FROM OTHER SOURCES:
As our society is newly formed, we are ineligible for many of the grants offered by regional districts & provincial funding bodies. For 2012 we have been focusing our efforts on sponsorship, continuing and creating new partnerships with local businesses, we have, or are in the process of, applying for grants/donations/sponsorships from Vantage One Credit Union, The Rotary Club, Armstrong Regional Co-op and the Lion's Club. Effort to identify new possible funding sources are ongoing.

A PROFILE AND HISTORY OF THE ORGANIZATION AND ITS ACCOMPLISHMENTS: BCBA formed as a society in the spring of 2019, but our board of directors have been involved with the Vernon Hot Air Balloon Festival and the sport of Hot Air Ballooning for a number of years. Our focus for 2020 is to start with a successful Hot Air Balloon Festival, adding educational programs throughout the coming year and years.

SERVICE PROVIDED TO THE COMMUNITY: The festival provides an economic boost to Vernon. The pilots are their support team stay in Vernon & support local businesses. Our education programs, which teach crewing & piloting skills require training space which again boost the economy & provides a unique spiky education. Other activities that run during the festival (large event & "where's Mini" are designed as fun activities for children and their families. The festival offers local businesses a unique advertising opportunity. The festival is a great tourism event. The spectacular balloon glow duplicates the balloon in all their glory and draws thousands of spectators, young & old every year. What an opportunity to showcase our beautiful city to locals & visitors alike!

ORGANIZATION GOALS, OBJECTIVES AND ACTIVITIES: The British Columbia Ballooning Association's (BCBA) mission is to introduce and educate the public to the sport of Hot Air Ballooning while entertaining the public with Hot Air Balloon events. One such event, one of only two held in western Canada is our Hot Air Balloon Festival, a three day competitive festival that coincides with the sport of Vernon's winter carnival. The three day festival brings 10 to 15 pilots some ranked in the top 50 in the world, to Vernon to showcase their skills.





The Corporation of the City of Vernon

COUNCIL DISCRETIONARY GRANT APPLICATION FORM

GRANT REQUEST

(You may wish to provide attachments, please note below where these items can be found.)

AMOUNT OF REQUEST: We are requesting \$3,218.⁰⁰ to cover the cost of pilot accommodations and crew training sites (briefing room & outdoor park area)

IN-KIND SERVICES: (please describe and include cost)

We are not requesting any in-kind services at this time as many of our sponsoring partners are providing "in kind" donations

PURPOSE OF GRANT AND PROPOSED ALLOCATION OF FUNDS: In order for the festival to happen, we need to provide accommodations to the pilots that are volunteering their time to participate in the festival. Without the pilots & their balloons, there simply is no festival. The pilots will arrive on the Thursday night and stay through until Sunday evening. The cost quote: \$2430. The briefing room & park space are used to train approx. 40 people in how to crew and/or officiate a balloon competition. This is a unique opportunity to learn about the sport of Hot Air Ballooning. Cost quote: \$788.

BENEFITS TO COMMUNITY RESULTING FROM GRANT OR CITY GOALS AND OBJECTIVES THAT WILL BE MET, IF THE GRANT IS APPROVED: In addition to the beautiful site of Hot Air Balloons in the skies above Vernon, and the opportunity to learn skills from pilots that are ranked among the top 30 in the world, the tourism and economic benefits to the city are immense. Food, lodgings and advertising opportunities for local businesses are just a few of these benefits. This is a truly unique opportunity that no other community in BC offers. And everyone can experience it! All they have to do is look up at the sky and watch these beautiful airships in action.

DEGREE OF COMMUNITY FINANCIAL SUPPORT OR SPONSORSHIP:

To date we have raised approx \$6,000 from the community and we are in the early stages of our fundraising efforts. The Hot Air Balloon Festival is now in its 29th year in Vernon. Festivals do not run for that many years without a huge degree of community support. This is a great economic and tourism opportunity for Vernon. Our sponsor partners know this. We sincerely hope that the city of Vernon will lend its support to our efforts by granting this request.

City Hall Address: 3400 30th Street, Vernon BC, V1T 5E6
 Inquiries: 250-545-1361
 Web: www.vernon.ca



The Corporation of the City of Vernon

COUNCIL DISCRETIONARY GRANT APPLICATION FORM

DEGREE OF DEMONSTRATED ECONOMIC DEVELOPMENT, ENVIRONMENTAL STEWARDSHIP OR SOCIAL BENEFIT THAT MAY BE GENERATED BY THE AWARD OF A COUNCIL DISCRETIONARY GRANT:

- Tourist attraction that no other community in BC offers
- Encourages participation in an amateur sport by teaching crewing and officiating skills. Trawlers are Pilots & crews that are ranked among the top 30 in the world.
- The number of spectators grows every year, all of whom contribute to the local community
- A unique advertising opportunity for our local businesses.
- Festival coincides with Vernon Winter Carnival and draws crowds to both events, increasing economic benefit to everyone involved.

All of which demonstrates a high degree of economic and social benefit to the city of Vernon.

GRANT QUALIFICATION CHECKLIST (please check all that apply):

- Community Based
- Providing a service which is not provided by any other group or organization within the City or which is provided for in another municipality and used by residents
- Must only submit one application per calendar year
- Grant request is not to cover retroactive funding or to cover a deficit

Note: Organizations do not qualify for the discretionary grant program if they are in receipt of regional funding or are receiving grants or other assistance from the City of Vernon. *not in receipt of any other regional or city funding*

GRANT REQUIREMENTS (please attach to your grant application):

- Most Recent Set of Financial Statements
- Minutes of Most Recent Annual General Meeting
- List of Members of the Executive (including positions held, address and contact numbers)

In the case of newly formed groups, a budget and information regarding the organization purpose including list of Board of Directors will be sufficient.

04 30 2019
Date

L Carey
Signature

City Hall Address: 3400 30th Street, Vernon BC, V1T 5E6
Inquiries: 250-545-1361
Web: www.vernon.ca

	<u>Budgeted Costs</u>	<u>Received to Date</u> (incl. cash and "in kind")
Fees		
Transportation Canada	\$ 60.00	\$
Insurance	\$ 3,000.00	\$
Landowner costs	\$ 300.00	\$
Fence rental	\$ 60.00	\$
Miester Fees	\$ 1,000.00	\$
subtotal	\$ 4,420.00	\$
Pilot Costs		
Propane	\$ 6,500.00	\$
Accommodations	\$ 2,430.00	\$
Nitrogen	\$ 150.00	\$ 150.00
Welcome Bags	\$ 750.00	\$ 750.00
subtotal	\$ 9,830.00	\$ 900.00
Volunteer Costs		
Appreciation gift bags	\$ 600.00	\$
Thank you cards	\$ 70.00	\$ 70.00
subtotal	\$ 670.00	\$ 70.00
Training Costs		
Room rental	\$ 633.00	\$
Park rental	\$ 155.00	\$
Tent rental	\$ 30.00	\$
Table rental	\$ 10.00	\$
New Pilot invitations	\$ 180.00	\$ 150.00
Training materials	\$ 1,000.00	\$
subtotal	\$ 2,003.00	\$ 150.00
Event Costs		
Glow	\$ 5,145.00	\$
Flight competitions	\$ 3,600.00	\$
Banquet	\$ 3,100.00	\$
Meet and Greet	\$ 3,300.00	\$
Door Prizes	\$ 500.00	\$
subtotal	\$15,645.00	\$
Contest Costs		
T-shirt contest	\$ 4,000.00	\$
Colouring contest	\$ 250.00	\$
Bingo contest	\$ 260.00	\$
Mini contest	\$ 150.00	\$
subtotal	\$ 4,660.00	\$
Advertising		
Winter Carnival Brochure	\$ 1,500.00	\$ 1,500.00
Newspaper	\$ 3,260.00	\$ 3,260.00
subtotal	\$ 4,760.00	\$ 4,760.00
Total Budget	\$41,988.00	

Name of Organization: British Columbia Ballooning Association

Contact Person: Lori Carey

Organization Mailing Address: [REDACTED]

Business Phone: [REDACTED]

Email Address: [REDACTED]

Registered Non Profit Society: S007141
Incorporation Number

Organization Goals, Objectives and Activities:

The British Columbia Ballooning Association's (B.C.B.A) mission is to introduce and educate the public to the sport of Hot Air Ballooning while entertaining the public with hot air balloon events. Once such event, one of only two held in Western Canada is our Hot Air Balloon Festival, a three day competitive festival that coincides with the start of Vernon's Winter Carnival.

The three day festival brings 10 to 15 pilots, some ranked among the top thirty in the world, to Vernon to showcase their skills in flying mountainous and cold temperature terrains.

Service Provided to the Community:

The festival provides an economic boost to local businesses. The pilots and their support teams stay in Vernon and support local businesses while they are here.

Our education programs, which teach crewing and officiating skills, require briefing room space which again boosts the local economy, while providing a unique sporting education to those interested in hot air ballooning.

Other activities that run during the festival, such as the hot air balloon themed bingo event and the "Where's Mini" treasure hunt contest, are designed as fun activities for children and their families. These events encourage participants to travel around Vernon, getting to know about our local businesses while learning about balloons and the sport of hot air ballooning.

The festival offers local businesses a unique advertising opportunity.

The festival is a great tourism event. The spectacular balloon glow, which happens on the Friday night at the start of the festival, displays the balloons in all their glory and draws thousands of spectators, young and old every year. What an opportunity to showcase our beautiful city and all that it offers to locals and visitors alike!

A Profile and History of the Organization and It's Accomplishments:

B.C.B.A formed as a society in the spring of 2019, but our board members have been involved with the Vernon Hot Air Balloon Festival and the sport of Hot Air Ballooning for a number of years. Our focus for 2020 is to start with a successful Hot Air Balloon Festival, adding educational programs throughout the coming year and years.

Please Identify the Steps your Organization has taken to Acquire grants from other sources:

As our society is newly formed, we are ineligible for many of the larger grants offered by regional districts and provincial funding bodies. For the current year, we have been focusing on sponsorship efforts, continuing and creating new partnerships with local businesses. We have or are in the process of applying for grants, and "in kind" grants from Vantage One Credit Union, The Rotary Club, Armstrong Regional Co-op, and the Lions Club.

Amount of Request:

We are requesting \$3,218.00 to cover the costs of pilot accommodations and crew training locations (briefing room and park area).

In-Kind Services: (please describe and include cost)

We are not requesting any In Kind services at this time as many of our sponsoring partners are providing "In Kind" donations.

Purpose of Grant and Proposed Allocation of Funds:

In order for The Balloon Festival to happen, we need to provide accommodations to the pilots that are volunteering their time to participate in the festival. Without the pilots and their balloons, there simply is no Festival. The pilots will arrive on the Thursday night and stay through until Sunday evening. The cost quote that we have been given for accommodations is \$2,430.

The briefing room and park rental space are used to train approximately forty people in how to crew a hot air balloon and/or officiate a competition. This is a unique opportunity to learn about the sport of Hot Air Ballooning. The training, and briefing sessions occur before and during the Festival. Our cost quote for the briefing room and park space is \$788.

Benefits to Community resulting from Grant or City Goals and Objectives that will be met, if the Grant is approved:

In addition to the beautiful site of Hot Air Balloons in the skies above Vernon, and the opportunity to learn about a sport from pilots that are ranked among the top 30 in the world, the tourism and economic benefits to the city are immense: Food, lodgings, and advertising opportunities for local businesses are just a few of these benefits.

This is a truly unique opportunity that no other community in BC offers.

And everyone can experience it. All they have to do is look up into the sky. No ticket prices, no accessibility barriers...simply stop and look up at the sky and watch these beautiful air ships in action.

Degree of community Financial Support or Sponsorship:

To date, we have raised approximately \$6,000 from the community and we are in the early stages of our sponsorship and fundraising efforts.

The Hot Air Balloon Festival is now in its 29th year in Vernon. Festivals do not run for that many years without a huge degree of community support. This is a great economic and tourism opportunity for Vernon. Our sponsorship partnerships know this. We sincerely hope that the City of Vernon will lend its support to our efforts by granting this request.

Degree of Demonstrated Economic Development, Environmental Stewardship or Social Benefit that may be generated by the award of a council Discretionary Grant.

Tourist attraction that no other community in BC offers

Encourages participation in an amateur sport by teaching crewing and officiating skills. Trainers are pilots and crews that are ranked among the top thirty in the world.

The number of spectators grows every year, all of whom contribute to the local community.

A unique advertising opportunity for local businesses

The festival co-insides with the Vernon Winter Carnival and draws crowds to both events, increasing the economic benefit to everyone involved.

All of which demonstrates a high degree of economic and social benefit to the city of Vernon.



Dear Vernon City Council Members,

Thank you for taking the time to review our application for the Council Discretionary Grant.

Attached is our application. We were unable to type directly on the application form, so we have provided the completed form in handwriting and attached a typed copy should you find that easier to read.

As you will see in the following pages, we are requesting \$3218 to cover the cost of pilot accommodations and training space for the 2020 Hot Air Balloon Festival.

The Festival is a 3 day competitive event that will run February 7 - 9, 2020. Ten to fifteen Hot Air Balloon Pilots will be competing in the 2020 festival, some of whom are ranked among the top 30 in the world. The competition also offers training to anyone interested in learning how to crew and/or officiate a Hot Air Balloon Event.

The benefits of the festival to Vernon:

- It is a tourist attraction that no other community in B.C. offers.
- It encourages participation in an amateur sport by teaching crewing and officiating skills; trainers are pilots and crew members some of whom are ranked among the top 30 in the world.
- The number of spectators grows every year, all of whom contribute to the local community.
- It offers a unique advertising opportunity for our local businesses.
- It coincides with the Vernon Winter Carnival and draws crowds to both events, increasing the economic benefit to everyone involved.

Thank you again for considering our request.



The Corporation of the City of Vernon

COUNCIL DISCRETIONARY GRANT APPLICATION FORM

IMPORTANT: The deadline for Council Discretionary Grant Applications are semi-annual being April 30 and October 31 each calendar year.



Applications will only be accepted during the intake periods of April 1 - April 30 and October 1 to October 31. Applications must be submitted to the Director of Financial Services no later than 4:00pm on the application deadline (April 30th and October 31st), if City Hall is closed that day, on the next working day that City Hall is open.

Applicants may run the risk of grant funding being depleted if waiting to apply until the October intake deadline.

If grant applications are received after the cut off periods they will be returned to the applicant and must be submitted at the next intake period.

Please note: Incomplete applications will not be considered

ORGANIZATION INFORMATION

NAME OF ORGANIZATION APPLYING FOR COUNCIL DISCRETIONARY GRANT:	Buoyant Buddies North Okanagan Dragonboat Society
CONTACT PERSON:	Nancy Street
ORGANIZATION MAILING ADDRESS:	Buoyant Buddies North Okanagan Dragonboat Society, P.O. Box 20017, Vernon BC V1T9Z4
BUSINESS PHONE:	[REDACTED]
EMAIL ADDRESS:	vernonbbs@gmail.com
REGISTERED NON PROFIT SOCIETY INCORPORATION NUMBER (required):	50058471

"Personal information contained on this form is collected under the Freedom of Information and Protection of Privacy Act and will be used only for the purposes of responding to your request".

City Hall Address: 3400 30th Street, Vernon BC, V1T 5E6
Inquiries: 250-545-1361



The Corporation of the City of Vernon

COUNCIL DISCRETIONARY GRANT APPLICATION FORM

ORGANIZATION GOALS, OBJECTIVES AND ACTIVITIES: our goal/mission is to raise breast cancer awareness in our community + demonstrate that women who are living with the disease can lead active lives. Our aim is to improve the physical + psychological well-being of people with breast cancer, as well as support them.
activity: we are a breast cancer dragon boat team paddling on Swan Lake as a member of the Vernon Rowing + Dragon Boat Club (VRDBC)

- SERVICE PROVIDED TO THE COMMUNITY:**
- Healthy fitness + fun oriented support for breast cancer survivors
 - Organize the Cancer Carnation Ceremony at the Vernon dragon boat festival.
 - Volunteer at the Cancer Clinic (VGH) one day/week
 - Raise money for Vernon Jubilee Foundation (50/50 draw) at the Vernon dragon boat festival
 - Have a table at Sunshine Festival
 - Created the dragon + breast cancer symbol on the "mosaic river" at the cenotaph park

A PROFILE AND HISTORY OF THE ORGANIZATION AND ITS ACCOMPLISHMENTS:

History: Fall 2003 created our team
 Spring 2004 started paddling
 2011 applied for non-profit status (50058471)
 Participated in: Health Awareness Day, Hospice walk + tea, cancer affected sale, Safeway's Awareness Day, Ferry Fox Run, Run for the Cure, any awareness function of BC + Yukon Breast Cancer Society in Vernon, volunteer 1 day/week at Cancer clinic.
 Fundraising activities: sold mittens, cookbooks, cool-ties, flowers.
 Pub night with silent auction + 50/50 draw. 50/50 tickets at the Vipers games.
 Great Vernon ambassadors at out of town festivals: Penticton, Kelowna, Kamloops, Salmon Arm + at international breast cancer festivals: 2005 Van Courva, 2007 Australia, 2010 Peterborough, 2014 Florida, 2018 Italy.

PLEASE IDENTIFY THE STEPS YOUR ORGANIZATION HAS TAKEN TO ACQUIRE GRANTS FROM OTHER SOURCES:

- BC + Yukon Cancer Society. Their mandate changed a few years ago. no more grants, all money goes to research now. (\$2000)
- Fantastic 2012: 24 carbon paddles (\$4846.26)
- Ladies Auxiliary Fraternal Order of Eagles (\$1000)



The Corporation of the City of Vernon COUNCIL DISCRETIONARY GRANT APPLICATION FORM

GRANT REQUEST

(You may wish to provide attachments, please note below where these items can be found.)

<p>AMOUNT OF REQUEST: 4 life jackets from Innerspace Water sports, Vernon</p> $4 \times \$119.99 = 479.96$ $\text{GST } 5\% = 24.-$ <hr/> <p>Total 503.96</p>
<p>IN-KIND SERVICES: (please describe and include cost)</p> <p>We receive none</p>
<p>PURPOSE OF GRANT AND PROPOSED ALLOCATION OF FUNDS:</p> <p>We need life jackets for new members joining us, especially L+XL Our club is growing (a sweet/sour reality) as more women are diagnosed with breast cancer and/or population growth.</p>
<p>BENEFITS TO COMMUNITY RESULTING FROM GRANT OR CITY GOALS AND OBJECTIVES THAT WILL BE MET, IF THE GRANT IS APPROVED:</p> <p>Benefits to Community: being able to support all breast cancer survivors in our community to stay healthy + active.</p> <p>Objective: being able to accommodate any new members joining our team.</p>
<p>DEGREE OF COMMUNITY FINANCIAL SUPPORT OR SPONSORSHIP:</p> <ul style="list-style-type: none"> • Quite a few businesses support us with silent auction items, plus we get every year carnations donated (this year 75) for the breast cancer carnation ceremony during the Vernon dragon boat festival. • Nature's Fare donates 3% of our receipts to our cause • Some businesses have in the passed supported us financially, but also quite a few had to decline in the last few years due to economics.

City Hall Address: 3400 30th Street, Vernon BC, V1T 5E6
Inquiries: 250-545-1361



The Corporation of the City of Vernon

COUNCIL DISCRETIONARY GRANT APPLICATION FORM

DEGREE OF DEMONSTRATED ECONOMIC DEVELOPMENT, ENVIRONMENTAL STEWARDSHIP OR SOCIAL BENEFIT THAT MAY BE GENERATED BY THE AWARD OF A COUNCIL DISCRETIONARY GRANT:

Social Benefit:

- raise breast cancer awareness in our community
- support + encourage people dealing with breast cancer
- demonstrate that women with breast cancer can lead active lives
- be inspiring ambassadors at out of town festivals
- keep our seniors with breast cancer healthy + active (our oldest is 84yrs old)

GRANT QUALIFICATION CHECKLIST (please check all that apply):

- Community Based
- Providing a service which is not provided by any other group or organization within the City or which is provided for in another municipality and used by residents
- Must only submit one application per calendar year
- Grant request is not to cover retroactive funding or to cover a deficit

Note: Organizations do not qualify for the discretionary grant program if they are in receipt of regional funding or are receiving grants or other assistance from the City of Vernon.

GRANT REQUIREMENTS (please attach to your grant application):

- Most Recent Set of Financial Statements
- Minutes of Most Recent Annual General Meeting
- List of Members of the Executive (including positions held, address and contact numbers)

In the case of newly formed groups, a budget and information regarding the organization purpose including list of Board of Directors will be sufficient.

28 X 2019
Date

D. Radomske (D. Radomske)
Signature Secretary

City Hall Address: 3400 30th Street, Vernon BC, V1T 5E6
Inquiries: 250-545-1361

Buoyant Buddies Treasurers Report October 16, 2019

OPENING BALANCE January 01/2019	\$14315.47
DEPOSITS: January 01/2019-October 16/2019	\$13192.84
EXPENSES: January 01/2019-October 16/2019	(\$16176.48)

ENDING BANK BALANCE
OCTOBER16/2019

Checking Account:	\$4331.83
GIC-(matures03/2020):	\$7000.00
TOTAL:	\$11331.83

REVENUE:

Membership:	\$4025.50
Donations:	\$ 200.00
Fundraising:	\$8836.35
Nature'sFare:	\$130.99

TOTAL REVENUE: \$13192.84

EXPENSES:

Bank Charges:	\$32.50
Office Expenses:	\$457.05
Paddling & Coaching Fees:	\$6500.25
Miscellaneous:	\$1731.56
Uniforms & Equipment:	\$3849.48
Festivals:	\$3556.50

TOTAL EXPENSES: \$16176.84

NET INCOME (LOSS) (\$2984.00)



BUOYANT BUDDIES

ANNUAL GENERAL MEETING

October 17th, 2019

Held at Inglewood Community Hall, 1001-30Ave (MaryEllen's)

Present: Joanne (aka Josie) Taylor, Deb Bachman, Sharon Hoffman, MaryEllen MacGregor, Lorna Quinn, Annette Kovach, Bonnie Davidson, Alexis Kovacevic, Susan Wilson, Gillian Wells, Nancy Street, Linda Large, Aislinn Harmston, Denise Radomske and new member Donna Gregoire.

Excused: Christina Linwood, Gayle Wilson, Henriette Hoeksema, Rona Short, Cathy Mori, Sue Gilowski, Shelley Blanchard, Sophie Jansen, Deanne Graham, Debbie Stoddard, Tom MacKay, Robyn Kendall, Judy Stockdale, Sandi Sasges.

Call to Order: by MaryEllen at 6:55pm, meeting chaired by MaryEllen.

Remembrance of Lost Team Members:

Joanne gave a nice speech and prayer for our 'angels': Eli Lockwood, Emma Okrainec, Ruth Schaefer, Val Woodcock, Marie Esau, Marnie Hodge, Judy Symington, Brenda Vodden, Judy Gurney, Pat Cookson, Wendy Schafer, Annette Sept, Ruth Coxson, Angela Hemming, Marie Rogers and Barb Geislinger, Julie Vardabasso. A candle remained lit for the whole meeting.

Adoption of 2018 minutes:

Accepted by Gillian Wells and seconded by Denise Radomske; carried.

Financial report:

Nancy Street handed out and read the financial report. Gillian Wells accepted and Lorna Quinn seconded it.

Opening balance: January 01/2019	\$14315.47
Deposits: January 01/2019-October 16/2019	\$13192.84
Expenses: January 01/2019-October 16/2019	(\$16176.48)
Bank balance: October 16/2019	\$11331.83

OLD BUSINESS

Team Manager/Festival Coordinator: (Debbie Stoddard) MaryEllen MacGregor read out Debbie's report:

Sunshine Festival: to show our presence for breast cancer awareness.

Shuswap Festival: 17 of us participated. Could not find race times on website.

Vernon Festival: Full boat, Annette was the speaker for the Breast Cancer Celebration.

Race times: 3:06.58/3:12.63/3:07.96

Kamloops Festival: we did not attend as a team, only MaryEllen joined Quesnel's team.

Penticton Festival: 18 of us participated. Race times: 2:44.37/5:15(we know why)/2:43/46

Breast Cancer Challenge race: 2:36.77.

Kelowna Seniors Games: 10 BB's & 10 Dragon Riders "The Dragon Buddies" participated. Race length 460m. Times: 2:38.96/2:47.56/2:54.66 and final 'D' Division: 2:58.70

Flowers: (*Annette Kovach*) Carnation Ceremony - Annette got the flowers from Save-On this year. She asked for 50 and they so kindly gave her 75. Every year she approaches a different business, so as not to be a burden.

Social: (*Joanne Taylor, Nancy Street, Sharon Hoffman*)

Joanne recalled our lovely Christmas party bowling, pub night at Village Green and season end potluck at Duke's place.

This December our Christmas dinner will be on **Friday December 6th** at the Outboard Waterfront Pub. The majority decided for the "Rudolf" menu @ \$19.00 with tax (5%) & tip (18%) would come to \$23.37.

Fundraising: (*MaryEllen MacGregor, Sharon Hoffman & Deb Stoddard*)

The 50/50 ticket sale at the Vipers' game, which Deb B. organized, turned out to be a great fundraiser for us. Also many thanks to Sharon H. for her hard work with the garage sale and offering her place for it. We also had our hamburger/silent auction pub night organized by MaryEllen.

Scrapbook: (*Bonnie Davidson*)

Any photos anyone has re: any functions, actions of BB's and/or the team can be sent by e-mail or in print to her.

Uniforms/storage locker/equipment: (*Gillian Wells*)

We got 30 new Jerseys, 13 more pink backpacks and hats, as well as 104 crests. Wooden and black paddles have been repaired and shortened. MaryEllen with a retired Graphic artist friend of hers made up a new logo for the team. MaryEllen also made up a team photo/Thank-you card to be handed out to donors/sponsors. Right now MaryEllen is working on a new rack card to be displayed at our publicity events and put in the Cancer Clinic and Mammogram room.

Nature's Fare receipts: (*Lorna Quinn*)

We are getting 3% back on any receipts submitted; we got \$130.99 so far this year. Please collect all Nature's Fare receipts. Suggestion: you could buy a gift card to give as a present; maybe relatives/good friends who shop there are willing to hand over their receipts to you?

Facebook: Thanks to MaryEllen MacGregor who has been posting pictures and data on the Buoyant Buddies' Face Book site.

Attendance: (*Lorna Quinn*)

Lorna would like to award people with the best attendance next year since regular attendance is so important to the development of our team.

Volunteer at Cancer Clinic: Annette reported what is involved - put on coffee, check on patients who may need water, warm blankets or whatever; check supplies and ask whatever else one could do for them; 11am pick up sandwiches from the cafeteria and offer sandwiches/beverages to patients for free. Wednesday mornings from 8:30-noon. Volunteers will take turns each Wednesday.

NEW BUSINESS

Welcome package: is a work in progress. Bonnie Davidson will make the necessary changes and e-mail the most current version. In Spring, more talk will be held about the roles of Coach, Steerperson and Drummer.

Festivals: Local ones will be addressed by Deb Stoddard at the next meeting in February 2020.

International Festival 2020 in NZ: Of those present at the AGM, the vast majority voted for participating in the festival. Bonnie will be the liaison between IBCPC (International Breast Cancer Paddlers' Commission) and our team and will forward the newsletters as they arrive. On November 30, 2019, NZ will announce the date of the festival and registration will be open in March 2020. We will need a committee of two people looking into accommodation and travel.

New Member's Social: This is expected to be a Meet and Greet in April. Bonnie Davidson hopes to have a 'Welcome package' prepared for all new comers as well as current members. Aislinn Harmston will organize and advertise the event.

Membership Dues: \$150 will be due on our next meeting in February 2020. Gillian Wells wrote a great letter which will be submitted to VRDC board members in the hope to get a reduced membership fee. Bonnie Davidson will take over as Gillian is heading South on 21st October.

Carnival: A meeting will be held on November 4th. Aislinn Harmston will go to it. Question is whether we will go into the parade. Not much enthusiasm was shown at the AGM.

Fundraising:

Grant application for City of Vernon - Nancy Street and Denise Radomske will get the application going, due Oct 31 2019. It was decided to apply for life jackets.

Selling a flower basket or herb bowl: Greenbush Greenhouses & Farm in Lumby is offering the fundraiser for Mothers' Day.

We will sell: 13" Spring basket for \$35 and our team makes \$13. or
 Fresh herb bowl for \$30 and our team makes \$10.

Last day of order is March 12th 2020. It was decided we will try this fundraiser. More info coming after Christmas.

Pub night/silent auction: we will have this again in March 2020. The other 2 dragon boat teams will join in again. We hope they will take over the 50/50 draw this time.

Vipers 50/50 ticket sale: hopefully we will get some more. Deb Bachman will look into it.

Garage sale: depends on Sharon Hoffman's location and her health. Discussed next meeting February 2020. Cathy Mori's neighbours offered to let us have it at their place. Suggestion was brought up to have coffee/goodie table in Lavington so as to tell people and direct them to our new location.

Sharon Hoffman suggests we should go again for sponsorship to businesses. MaryEllen will get in touch with Gwen Davidson who was on that committee.

Ladies Auxiliary Fraternal Order of Eagles: Deb Bachman will look into the application for a grant of \$1000

Uniforms/ Equipment/Roster: Gillian Wells still stores our equipment. Christina Linwood will help with the sign-out/in sheet and also take over the Roster. Please send any address/phone changes to Christina. New Jackets: Price \$140.- ea. Only a few will need/want one, to be discussed at meeting in February 2020. New banner flag: MaryEllen MacGregor and Susan Wilson are looking into the cost.

Attendance: (*Lorna Quinn*) Members who cannot attend a practice must phone Lorna by 10am on the practice day. She can't stress enough how important it is to let attendance person know if you are not coming. Some people have to leave their place more than one hour ahead of practice time, so they are not impressed to get there, just to be told there aren't enough paddlers. 12 paddlers are needed to take the boat out on a good day. Even if preferred notice time is over and an emergency or sudden ill feeling comes up, please still phone Lorna. Bonnie will send an email by noon on any practice day that must be cancelled. We must all check our e-mails before practice.

Cancer Clinic Volunteers: (*Annette Kovach, Joanne Taylor, MaryEllen MacGregor, Alexis Kovacevic*) Please contact Annette if you are interested in volunteering. Volunteer time is Wednesday 8:30- noon. Volunteers will take turns each Wednesday. The more volunteers we have, the less often your turn comes up.

Media/Publicity: Deb Bachman thinks we should do more publicity for our team, especially in October which is Breast Cancer Awareness month. ScotiaBank and CIBC do a great deal in October. Perhaps we can approach them to put up an information table as we do during Sunshine Festival. A committee was formed by Susan Wilson, Deb Bachman and Gillian Wells.

ELECTION OF OFFICERS

President: Bonnie Davidson
Vice President: Aislinn Harmston
Past President: MaryEllen MacGregor
Secretary: Denise Radomske
Treasurer: Nancy Street

COMMITTEES

Team Captains: Deb Bachman & Alexis Kovacevic
Sponsorship/Fundraising: MaryEllen MacGregor, Sharon Hoffman & Deb Stoddard
Team Manager/Festivals: Debbie Stoddard & Christine Linwood
International Festival: Bonnie Davidson
Festivals: Debbie Stoddard & Christina Linwood
Attendance Manager: Lorna Quinn
Florist: Annette Kovach
Sunshine: Lorna Quinn & Annette Kovach
Social: Nancy Street, _____, _____
Scrapbook: Bonnie Davidson
Equipment: Gillian Wells & Christina Linwood
Cancer Clinic Volunteer: Annette Kovach, MaryEllen MacGregor, Joanne Taylor, Alexis Kovacevic,
_____ & _____
Media/Publicity for October Deb Bachman, Gillian Wells, Susan Wilson,

N.B. We are still looking for members to volunteer for the positions left vacant. Please email Bonnie if interested)

OTHER RESPONSIBILITIES

Coach: Susan Wilson
Steer: Tom MacKay & Cathy Mori
Drum: Annette Kovach
Roster: Christina Linwood
Facebook, email acct: MaryEllen MacGregor
Nature Fare receipts: Lorna Quinn

Meeting was adjourned at 9:30pm.

Respectfully submitted,
Denise Radomske, Secretary



Canadian Mental
Health Association

Mental health for all



Mayor Victor Cumming
City of Vernon
3400 30th Street
Vernon BC, V1T 5E6

October 30, 2019

Re: Council Discretionary Grant Application

Dear Mayor Cumming:

Please accept the enclosed application from Canadian Mental Health Association, Vernon & District Branch for a Council Discretionary Grant.

We are applying for \$10,000 to continue and expand our vital early intervention and prevention initiatives with Vernon youth. As you know, we are facing a disturbing trend in youth suicide and opioid use.

CMHA is dedicated to reaching out to our community's youth, youth leaders, parents and the general community to ensure the best possible future for our young people to help them learn resilience and thrive.

Together we are changing and saving lives!

Julia Payson
Executive Director

Enclosures:

Grant Application Form
Most Recent Set of Financial Statements
Minutes of Most Recent Annual General Meeting
List of CMHA Board Members



The Corporation of the City of Vernon

COUNCIL DISCRETIONARY GRANT APPLICATION FORM

IMPORTANT: *The deadline for Council Discretionary Grant Applications are semi-annual being April 30 and October 31 each calendar year.*

Applications will only be accepted during the intake periods of April 1 - April 30 and October 1 to October 31. Applications must be submitted to the Director of Financial Services no later than 4:00pm on the application deadline (April 30th and October 31st), if City Hall is closed that day, on the next working day that City Hall is open.

Applicants may run the risk of grant funding being depleted if waiting to apply until the October intake deadline.

If grant applications are received after the cut off periods they will be returned to the applicant and must be submitted at the next intake period.

Please note: Incomplete applications will not be considered

ORGANIZATION INFORMATION

NAME OF ORGANIZATION APPLYING FOR COUNCIL DISCRETIONARY GRANT:	Canadian Mental Health Association, Vernon & District
CONTACT PERSON:	Eleanor Diekert
ORGANIZATION MAILING ADDRESS:	3100 28 Avenue Vernon BC V1T 1W3
BUSINESS PHONE:	250.542.3114 ext. 224
EMAIL ADDRESS:	eleanor.diekert@cmhavernon.ca
REGISTERED NON PROFIT SOCIETY INCORPORATION NUMBER (required):	10686 3731 RR0001

"Personal information contained on this form is collected under the Freedom of Information and Protection of Privacy Act and will be used only for the purposes of responding to your request".

City Hall Address: 3400 30th Street, Vernon BC, V1T 5E6
Inquiries: 250-545-1361
Web: www.vernon.ca



The Corporation of the City of Vernon

COUNCIL DISCRETIONARY GRANT APPLICATION FORM

ORGANIZATION GOALS, OBJECTIVES AND ACTIVITIES:

CMHA, Vernon & District Branch, is dedicated to promoting Mental Wellness in the community of Vernon and area. We believe in enabling individuals, groups, and communities to increase control over, and to enhance their mental health. As part of a federation that is a nation-wide leader and champion for mental health, we facilitate and provide resources required for individuals to maintain and improve mental health, community integration, build resilience, and support recovery from mental illness.

We are committed to providing an environment that is free from prejudice, discrimination and harassment and strive to reflect the entire community in our volunteers and staff, and promote equal access to the services we provide. We are part of a provincial and national organization, and as a leader and champion for mental health, CMHA facilitates access to the resources people require to maintain and improve mental health and community integration, build resilience, and support recovery from mental illness.

CMHA Vernon is committed to ensuring that our mission and operations embrace the whole community, and actively encourage the entire community to participate in and benefit fully from our services.

SERVICE PROVIDED TO THE COMMUNITY:

Our programs serve a diverse population in our community from youth aged 7 to seniors 75+ along the mental health spectrum. We provide education, employment and social connection for residents with a mental illness diagnosis and those experiencing mental health challenges, and a variety of supports for their families such as one-on-one support, educational opportunities and group support programs. CMHA provides affordable and supportive housing to more than 260 Vernon residents in 144 units.

We also prepare and serve more than 9,000 meals in our nutrition program, answer more than 6,500 calls on our Crisis Line which operates 24/7, 365 days a year, operate a daily telephone safety check-in service that provides more than 8,000 annual calls to isolated residents, provide mental health wellness and education programs and initiatives to more than 2,000 community members, and operate several social enterprise employment programs.

Our Recycling program diverts 10,000 tonnes of waste from landfills each year, while providing employment opportunities and skills development for individuals with mental health challenges. We are a WorkBC partner organization, providing one-to-one employment services to participants with mental health issues. We also provide training in Mental Health First Aid and SAFE Talk to community members such as educators and health workers, as well as mental health education in the workplace for a number of businesses and community organizations.

CMHA Vernon has a volunteer force of more than 80 individuals contributing over 24,000 hours of service to our community each year.



The Corporation of the City of Vernon

COUNCIL DISCRETIONARY GRANT APPLICATION FORM

A PROFILE AND HISTORY OF THE ORGANIZATION AND ITS ACCOMPLISHMENTS:

Founded in 1959, CMHA Vernon & District has been saving and changing lives while improving mental health in our community. CMHA provides programs and services for individuals and families of all ages across the spectrum of mental health providing support, education and rehabilitation.

CMHA Vernon's early accomplishments were establishing and helping to furnish and equip the inpatient psychiatric unit at the Vernon hospital. We provided funds for activities and amenities for patients to socialize and reconnect in the community. During the 1960s the organization began community-based education and programs, purchasing educational materials which were delivered to parent groups at schools, local non profit organizations, churches, health care workers and RCMP. In 1966, The Georgette Thrift Shop was established and continues to operate to this day, funding CMHA programs.

Through the past decades, CMHA has responded to changing community needs, taking on a leadership role in community sustainability. For more than three decades, we have operated the Crisis Line, with calls now exceeding 6,500 per year.

We have taken action on affordable and supportive housing by purchasing, developing and managing properties for those with mental illnesses, and low income families since the 1980s. Our services have expanded to include job training, skills development, numerous social enterprises and a partnership with WorkBC that started this April.

CMHA has become one of the City's largest non-profit housing providers, housing 260 residents in 144 units throughout Vernon. In 2018, the provincial government announced \$3 million in funds for CMHA Vernon to renovate its Albert Place facility to include additional units for seniors and families.

CMHA uses a framework of support developed by its National office as a central philosophy guiding the activities of the organization. This philosophy holds that the person experiencing mental illness is at the centre of any supportive mental health system. CMHA works with more than two dozen local agencies as community resource base to outline a range of possible resources in addition to the formal mental health system which can provide support to a person with mental illness.

CMHA's goal is to ensure that community members along the mental health spectrum live fulfilling lives in the community bolstered by the four basic elements of citizenship - Housing, education, work and income.

PLEASE IDENTIFY THE STEPS YOUR ORGANIZATION HAS TAKEN TO ACQUIRE GRANTS FROM OTHER SOURCES:

CMHA has received a \$10,000 grant from Community Foundation of the North Okanagan for our general Mental Health Awareness programs that would include our Youth Mental Health Education Sessions. We have received confirmation from United Way of mental health education program funding.

We have also applied to the Telus Community Board to support this program and have developed letters of request for funds to local businesses and individuals for their support of youth mental health.



The Corporation of the City of Vernon

COUNCIL DISCRETIONARY GRANT APPLICATION FORM

GRANT REQUEST

(You may wish to provide attachments, please note below where these items can be found.)

<p><u>AMOUNT OF REQUEST:</u></p> <p>\$10,000</p>
<p><u>IN-KIND SERVICES: (please describe and include cost)</u></p> <p>\$5,000 office space - \$650 phone - \$100 utilities - \$250 insurance - \$500 staff and management support - \$1,500 program evaluation (to ensure success and sustainability of program) \$1,500</p>
<p><u>PURPOSE OF GRANT AND PROPOSED ALLOCATION OF FUNDS:</u></p> <p>Youth & Community Mental Health Education Sessions: CMHA's ongoing dedication to early intervention and prevention through education to address Vernon's urgent crisis surrounding youth and young adult mental health has led to a vital need for expanded services for youth and educational resources. Suicide is the leading cause of injury-related death among children and youth in BC, with the North Okanagan having one of the highest suicide rates in the province. For every child and youth in BC who dies of suicide, there are more than 3,000 who identify having suicide ideation (2019 BC Coroners Service Report). Recommendations from the Coroner's Report include adopting mental well-being strategies as part of social emotional learning for students.</p> <p>Last year, CMHA piloted the Youth Mental Health Education Sessions project, a prevention-based education program for youth, youth leaders, teachers and parents. The one-hour sessions are facilitated by our Community Educator using evidence-based programming and take place in school and club settings to address youth mental health and wellness, suicide prevention, anxiety, depression and bullying. The sessions are designed to equip youth with the knowledge and tools to help manage mental health through building relationships and to provide a knowledge base of community resources for accessing help. Schools and individual classes may participate in multiple sessions throughout the year. In 2018 CMHA provided education sessions to 238 youth aged 12 to 18, as well as teachers and youth leaders. Due to lack of funding we had to decline sessions to more than 150 students. This year we plan to expand educational sessions to include parent organizations within schools and social service organizations who serve youth, and to provide printed resource and educational materials. Funds from the City grant would be used for program costs including development of customized curriculum, purchase of program supplies, transportation to schools and venues, and printing and distribution of our Suicide Prevention Handbook.</p>
<p><u>BENEFITS TO COMMUNITY RESULTING FROM GRANT OR CITY GOALS AND OBJECTIVES THAT WILL BE MET, IF THE GRANT IS APPROVED:</u></p> <p>Benefits to our community include an increased awareness of youth mental health disorders, decreased stigma surrounding seeking mental health services for youth, increased access to community mental health services and programs, increased ability to cope with stress and anxiety, and increased social connectedness and community belonging for youth. The program helps remove barriers to access by offering on-site programming during school hours.</p> <p>In 2018 CMHA conducted a series of Youth Community Forums, inviting a panel of speakers including psychiatrists, youth workers, and those with mental health lived experience. Some of the barriers to receiving mental health assistance included lack of transportation to services, lack of access to school counselors due to stigma and scheduling issues, and lack of time and finances to access services</p>

City Hall Address: 3400 30th Street, Vernon BC, V1T 5E6

Inquiries: 250-545-1361

Web: www.vernon.ca



The Corporation of the City of Vernon COUNCIL DISCRETIONARY GRANT APPLICATION FORM

outside of school. CMHA addresses these issues by providing in-school sessions free of charge.

Our community educator will track participants attending by sign-in sheet at all education sessions. Data will be compiled and measured against program goals. The results will guide planning for subsequent education sessions, as well as be shared with other youth agencies to develop best practices in ensuring youth receive the best possible mental health education and services in our community.

DEGREE OF COMMUNITY FINANCIAL SUPPORT OR SPONSORSHIP:

This year we received grants from Community Foundation of the North Okanagan and the United Way to partially fund our initiatives. A portion of our annual Ride Don't Hide event with support from more than 350 donors and 200+ riders helps fund our youth programs. Our youth and educational programming is also supported by private individuals and local 3rd party events presented by businesses and organizations.



The Corporation of the City of Vernon

COUNCIL DISCRETIONARY GRANT APPLICATION FORM

DEGREE OF DEMONSTRATED ECONOMIC DEVELOPMENT, ENVIRONMENTAL STEWARDSHIP OR SOCIAL BENEFIT THAT MAY BE GENERATED BY THE AWARD OF A COUNCIL DISCRETIONARY GRANT:

CMHA's Youth Connections Education program enhances the City of Vernon's goals of ensuring a youth friendly community and social sustainability by supporting the development of services and programs for youth with mental health challenges and youth at-risk.

Our sessions address mental health problems that can impede social development, leaving young people feeling socially isolated and stigmatized. Mental disorders may impact a youth's ability to make and retain a strong and supportive peer network or appropriate relationships with adults.

The program addresses transportation barriers for youth and parents, helps develop supportive peer networks, social connection with teachers, youth leaders and parents, and empowers youth with skills and knowledge to build resilience and establish a sense of purpose and belonging.

Underlying all of our programs and services is a non-judgmental, inclusive approach to create a welcoming atmosphere celebrating the diversity of our community members.

Our program incorporates support from non-profit and business sectors, as well as private individuals to ensure success and sustainability.

GRANT QUALIFICATION CHECKLIST (please check all that apply):

- Community Based
- Providing a service which is not provided by any other group or organization within the City or which is provided for in another municipality and used by residents
- Must only submit one application per calendar year
- Grant request is not to cover retroactive funding or to cover a deficit

Note: Organizations do not qualify for the discretionary grant program if they are in receipt of regional funding or are receiving grants or other assistance from the City of Vernon.

GRANT REQUIREMENTS (please attach to your grant application):

- Most Recent Set of Financial Statements
- Minutes of Most Recent Annual General Meeting
- List of Members of the Executive (including positions held, address and contact numbers)

In the case of newly formed groups, a budget and information regarding the organization purpose including list of Board of Directors will be sufficient.

October 28, 2019

Date

Signature

City Hall Address: 3400 30th Street, Vernon BC, V1T 5E6
Inquiries: 250-545-1361
Web: www.vernon.ca

**Canadian Mental Health Association
Vernon and District Branch**

**Financial Statements
For the Year Ended March 31, 2019**

**Canadian Mental Health Association
Vernon and District Branch**

**Financial Statements
For the Year Ended March 31, 2019**

Contents

Independent Auditor's Report	2 - 4
Financial Statements	
Statement of Financial Position	5
Statement of Changes in Net Assets	6 - 7
Statement of Operations	8
Statement of Cash Flows	9
Notes to Financial Statements	10 - 18
Schedule 1 - Statement of Changes in Replacement Reserve Fund	19
Schedule 2 - Statement of Revenues and Expenses - Programs	20



Tel: 250 545 2136
Fax: 250 545 3364
www.bdo.ca

BDO Canada LLP
2706 30th Avenue, Suite 202
Vernon, BC V1T 2B6

Independent Auditor's Report

To the directors of Canadian Mental Health Association - Vernon and District Branch

Opinion

We have audited the financial statements of Canadian Mental Health Association - Vernon and District Branch (the Association), which comprise the statement of financial position as at March 31, 2019, the statements of operations, changes in net assets and cash flows for the year then ended, and notes to the financial statements, including a summary of significant accounting policies.

In our opinion, the accompanying financial statements present fairly, in all material respects, the financial position of the Association as at March 31, 2019, and its financial performance and cash flows for the year then ended in accordance with Canadian accounting standards for not-for-profit organizations.

Basis for Opinion

We conducted our audit in accordance with Canadian generally accepted auditing standards. Our responsibilities under those standards are further described in the *Auditor's Responsibilities for the Audit of the Financial Statements* section of our report. We are independent of the Association in accordance with the ethical requirements that are relevant to our audit of the financial statements in Canada, and we have fulfilled our other ethical responsibilities in accordance with these requirements. We believe that the audit evidence we have obtained is sufficient and appropriate to provide a basis for our opinion.

Responsibilities of Management and Those Charged with Governance for the Financial Statements

Management is responsible for the preparation and fair presentation of the financial statements in accordance with Canadian accounting standards for not-for-profit organizations, and for such internal control as management determines is necessary to enable the preparation of financial statements that are free from material misstatement, whether due to fraud or error.

In preparing the financial statements, management is responsible for assessing the Association's ability to continue as a going concern, disclosing, as applicable, matters related to going concern and using the going concern basis of accounting unless management either intends to liquidate the Association or to cease operations, or has no realistic alternative but to do so.

Those charged with governance are responsible for overseeing the Association's financial reporting process.



Auditor's Responsibilities for the Audit of the Financial Statements

Our objectives are to obtain reasonable assurance about whether the financial statements as a whole are free from material misstatement, whether due to fraud or error, and to issue an auditor's report that includes our opinion. Reasonable assurance is a high level of assurance, but is not a guarantee that an audit conducted in accordance with Canadian generally accepted auditing standards will always detect a material misstatement when it exists. Misstatements can arise from fraud or error and are considered material if, individually or in the aggregate, they could reasonably be expected to influence the economic decisions of users taken on the basis of these financial statements.

As part of an audit in accordance with Canadian generally accepted auditing standards, we exercise professional judgment and maintain professional skepticism throughout the audit. We also:

- Identify and assess the risks of material misstatement of the financial statements, whether due to fraud or error, design and perform audit procedures responsive to those risks, and obtain audit evidence that is sufficient and appropriate to provide a basis for our opinion. The risk of not detecting a material misstatement resulting from fraud is higher than for one resulting from error, as fraud may involve collusion, forgery, intentional omissions, misrepresentations, or the override of internal control.
- Obtain an understanding of internal control relevant to the audit in order to design audit procedures that are appropriate in the circumstances, but not for the purpose of expressing an opinion on the effectiveness of the Association's internal control.
- Evaluate the appropriateness of accounting policies used and the reasonableness of accounting estimates and related disclosures made by management.
- Conclude on the appropriateness of management's use of the going concern basis of accounting and, based on the audit evidence obtained, whether a material uncertainty exists related to events or conditions that may cast significant doubt on the Association's ability to continue as a going concern. If we conclude that a material uncertainty exists, we are required to draw attention in our auditor's report to the related disclosures in the financial statements or, if such disclosures are inadequate, to modify our opinion. Our conclusions are based on the audit evidence obtained up to the date of our auditor's report. However, future events or conditions may cause the Association to cease to continue as a going concern.
- Evaluate the overall presentation, structure and content of the financial statements, including the disclosures, and whether the financial statements represent the underlying transactions and events in a manner that achieves fair presentation.

We communicate with those charged with governance regarding, among other matters, the planned scope and timing of the audit and significant audit findings, including any significant deficiencies in internal control that we identify during our audit.



Report on Other Legal and Regulatory Requirements

As required by the Societies Act (British Columbia), we report that, in our opinion, the accounting principles in Canadian accounting standards for not-for-profit organizations have been applied, on a basis consistent with that of the preceding year.

BDO Canada LLP

Chartered Professional Accountants

Vernon, British Columbia
June 25, 2019

**Canadian Mental Health Association
Vernon and District Branch
Statement of Financial Position**

March 31	2019	2018
Assets		
Current		
Cash and cash equivalents	\$ 975,046	\$ 824,048
Investments (Note 2)	80,304	122,325
Accounts receivable	31,427	65,654
Prepaid expenses	8,580	4,569
	<u>1,095,357</u>	<u>1,016,596</u>
Restricted cash (Note 3)	114,211	853,656
Investments (Note 2)	684,499	-
Property, plant and equipment (Note 4)	<u>12,543,997</u>	<u>12,050,006</u>
	<u>\$14,438,064</u>	<u>\$ 13,920,258</u>

Liabilities and Net Assets

Current		
Accounts payable and accrued liabilities (Note 5)	\$ 408,274	\$ 381,573
Deposits received	52,314	50,467
Deferred revenues	184,032	232,302
Short term debt (Note 6)	77,693	89,863
Current portion of long term debt (Note 7)	<u>452,733</u>	<u>439,959</u>
	<u>1,175,046</u>	<u>1,194,164</u>
Long term debt (Note 7)	6,568,847	7,021,622
Deferred capital contributions (Note 8)	<u>2,616,378</u>	<u>1,803,590</u>
	<u>10,360,271</u>	<u>10,019,376</u>
Net Assets		
Restricted	1,758,773	1,515,747
Unrestricted	<u>2,319,020</u>	<u>2,385,135</u>
	<u>4,077,793</u>	<u>3,900,882</u>
	<u>\$14,438,064</u>	<u>\$ 13,920,258</u>

On behalf of the Board:

 Director

 Director

The accompanying notes are an integral part of these financial statements.

**Canadian Mental Health Association
Vernon and District Branch
Statement of Changes in Net Assets**

For the year ended March 31	RESTRICTED			2019 Total	2018 Total
	Invested in Capital Assets	Replacement Reserve	Operations		
	(Schedule 1)				
Balance, beginning of the year	\$ 1,316,673	\$ 472,797	\$ (273,723)	\$ 1,515,747	\$ 1,293,611
Excess of revenues over expenses	(261,343)	-	504,369	243,026	82,871
Contributions received	(836,340)	-	836,340	-	-
Forgivable loan realized	-	-	-	-	139,265
Long term debt principal repayments	440,000	-	(440,000)	-	-
Purchase of capital assets	831,366	-	(831,366)	-	-
Replacement reserve provision	-	114,912	(114,912)	-	-
Interest on replacement reserve	-	3,020	(3,020)	-	-
Replacement reserve expenditures	-	(125,984)	125,984	-	-
Interfund transfers	-	19,393	(19,393)	-	-
Balance, end of the year	\$ 1,490,356	\$ 484,138	\$ (215,721)	\$ 1,758,773	\$ 1,515,747

The accompanying notes are an integral part of these financial statements.

**Canadian Mental Health Association
Vernon and District Branch
Statement of Operations**

For the year ended March 31	UNRESTRICTED			2019 Total	2018 Total
	Invested in Capital Assets	Internally Restricted	Operations		
		(Note 9)			
Balance, beginning of the year,	\$ 1,378,299	\$ 309,553	\$ 697,283	\$ 2,385,135	\$ 2,323,123
Excess (deficiency) of revenues over expenses	(55,563)	-	(10,552)	(66,115)	62,012
Contributions received	(73,537)	-	73,537	-	-
Internal restrictions	-	14,522	(14,522)	-	-
Long term debt principal repayments	12,170	-	(12,170)	-	-
Purchase of capital assets	76,580	-	(76,580)	-	-
Replacement reserve expenditures	-	(23,332)	23,332	-	-
Interfund transfers	-	23,332	(23,332)	-	-
Balance, end of the year	\$ 1,337,949	\$ 324,075	\$ 656,996	\$ 2,319,020	\$ 2,385,135

The accompanying notes are an integral part of these financial statements.

**Canadian Mental Health Association
Vernon and District Branch
Statement of Operations**

For the year ended March 31	2019	2018
	(Schedule 2)	
Revenue		
Interior Health Authority	\$ 2,180,183	\$ 2,019,090
Rent and user fees	1,068,780	1,040,065
BC Housing	703,833	587,034
Canadian Mental Health Association - BC Division	493,070	384,119
Donations and fundraising	223,552	173,914
Store sales	174,226	184,252
Grants - Other	144,489	59,238
Sundry	100,032	71,975
BC Gaming	99,116	77,500
Workshop sales	97,508	94,878
United Way	5,535	7,535
Amortization of deferred contributions (Note 8)	97,089	72,340
	5,387,413	4,771,940
Expenses		
Advertising and promotion	24,500	20,580
Amortization	413,995	401,434
Insurance	31,002	32,063
Interest and bank charges	8,414	6,261
Interest on long term debt	212,945	204,299
Memberships and licences	17,419	15,892
Office and miscellaneous	63,837	43,187
Professional development	42,858	619
Professional fees	28,567	26,447
Program expenses	237,717	150,342
Property taxes	2,351	7,759
Rent	15,832	16,889
Repairs and maintenance	329,425	352,382
Subcontracts	44,123	17,591
Supplies	94,190	92,153
Telephone	4,240	20,828
Travel	24,300	17,510
Utilities	342,172	323,738
Vehicle	28,309	28,230
Volunteer and honorariums	79,741	76,677
Wages and benefits	3,164,565	2,772,176
	5,210,502	4,627,057
Excess of revenues over expenses	\$ 176,911	\$ 144,883

The accompanying notes are an integral part of these financial statements.

**Canadian Mental Health Association
Vernon and District Branch
Statement of Cash Flows**

For the year ended March 31	2019	2018
Cash flows from operating activities		
Cash receipts from federal and provincial funding and grants	\$ 3,835,735	\$ 3,369,986
Cash receipts from rent and user fees	1,070,628	1,038,865
Cash received from other revenue	363,592	346,322
Cash paid to suppliers and employees	(4,560,874)	(3,967,110)
Interest received	8,174	4,783
Interest paid	(212,945)	(204,299)
	504,310	588,547
Cash flows from investing activities		
Purchase of investments	(642,478)	(1,066)
Capital contributions received	909,877	417,467
Purchase of capital assets	(907,985)	(1,680,166)
	(640,586)	(1,263,765)
Cash flows from financing activities		
Repayment of short term debt	(12,170)	(42,026)
Repayment of long term debt	(440,001)	(413,726)
Proceeds from long term debt	-	1,286,440
	(452,171)	830,688
Net (decrease) increase in cash and cash equivalents	(588,447)	155,470
Cash and cash equivalents, beginning of the year	1,677,704	1,522,234
Cash and cash equivalents, end of the year	\$ 1,089,257	\$ 1,677,704
Represented by:		
Cash and cash equivalents	\$ 975,046	\$ 824,048
Restricted cash (Note 3)	114,211	853,656
	\$ 1,089,257	\$ 1,677,704

The accompanying notes are an integral part of these financial statements.

**Canadian Mental Health Association
Vernon and District Branch
Notes to Financial Statements**

March 31, 2019

1. Significant Accounting Policies

Nature and Purpose of Organization	<p>The Canadian Mental Health Association - Vernon and District Branch (the "Association") is a branch of the Canadian Mental Health Association and was incorporated under the Society Act of British Columbia. The Association's purpose is to provide services that promote, maintain, and enhance the mental health of individuals in Vernon, British Columbia and the surrounding area.</p> <p>The Association is a registered charity and, as such, is exempt from income tax and may issue income tax receipts to donors.</p>
Basis of Accounting	<p>The financial statements have been prepared using Canadian accounting standards for not-for-profit organizations.</p>
Revenue Recognition	<p>The Association follows the deferral method of accounting for contributions.</p> <p>Restricted contributions are recognized as revenue in the year in which the related expenses are incurred. Unrestricted contributions are recognized as revenue when received or receivable if the amount to be received can be reasonably estimated and collection is reasonably assured.</p> <p>Restricted net investment income is recognized as revenue in the year in which the related expenses are incurred. Unrestricted net investment income is recognized as revenue when earned.</p> <p>Revenue from tenant rent is recognized when the cash is collected or when collection is reasonably assured.</p> <p>Store sales, workshop revenues, fundraising and other miscellaneous revenue are recognized in the respective programs when there is persuasive evidence of an arrangement, the services or goods have been provided and cash is collected or reasonably collectible.</p>
Use of Estimates	<p>The preparation of financial statements in accordance with Canadian accounting standards for not-for-profit organizations requires management to make estimates and assumptions that affect the reported amounts of assets and liabilities at the date of the financial statements, and the reported amounts of revenue and expenses during the reporting period. Actual results could differ from management's best estimates as additional information becomes available.</p>
Cash and Cash Equivalents	<p>Cash and cash equivalents consist of cash on hand and bank balances.</p>

**Canadian Mental Health Association
Vernon and District Branch
Notes to Financial Statements**

March 31, 2019

1. Significant Accounting Policies (continued)

Property, Plant and Equipment

Purchased property, plant and equipment are stated at cost less accumulated amortization. Contributed tangible capital assets are recorded at fair value at the date of contribution and are amortized, unless fair value is not determinable in which case contributed tangible capital assets are recorded at nominal value at the date of contribution. Expenditures for repairs and maintenance are expensed as incurred. Betterments that extend the useful life of the tangible capital asset are capitalized.

Amortization based on the estimated useful life of the asset is calculated as follows:

	Method	Rate
Buildings	Straight-line	40 years
Vehicles	Straight-line	5 years
Computer equipment	Straight-line	3 years
Furniture and equipment	Straight-line	10 years
Leasehold improvements	Straight-line	5-10 years

Financial Instruments

Financial Instruments are recorded at fair value at initial recognition.

In subsequent periods, equities traded in an active market and derivatives are reported at fair value, with any change in fair value reported in income. All other financial instruments are reported at cost or amortized cost less impairment. Transaction costs on the acquisition, sale or issue of financial instruments are expensed for those items measured at fair value and charged to the financial instrument for those measured at amortized cost.

Financial assets are tested for impairment when indicators of impairment exist. When a significant change in the expected timing or amount of the future cash flows of the financial asset is identified, the carrying amount of the financial asset is reduced and the amount of the write-down is recognized in net income. A previously recognized impairment loss may be reversed to the extent of the improvement, provided it is not greater than the amount that would have been reported at the date of the reversal had the impairment not been recognized previously, and the amount of the reversal is recognized in net income.

Contributed Materials

Due to the difficulty in determining the fair value of materials contributed to the organization they are not recognized in the financial statements.

**Canadian Mental Health Association
Vernon and District Branch
Notes to Financial Statements**

March 31, 2019

1. Significant Accounting Policies (continued)

Contributed Services Volunteers contribute many hours per year to assist the Association in carrying out its activities. Due to the difficulty of determining their fair value, contributed services are not recognized in the financial statements.

2. Investments

The carrying amount of investments are comprised of the following:

	2019	2018
At amortized cost:		
Canadian corporate bonds and term notes, bearing interest between 1.620% and 2.923% and maturing between April 2020 and November 2022	\$ 507,939	\$ -
Foreign corporate bonds, bearing interest between 2.222% to 2.840% and maturing between March 2021 and July 2023	176,560	-
At fair value:		
Cash and savings accounts	80,304	122,325
	\$ 764,803	\$ 122,325
Investments are allocated as follows:		
Current	\$ 80,304	\$ 122,325
Long term	684,499	-
	\$ 764,803	\$ 122,325

**Canadian Mental Health Association
Vernon and District Branch
Notes to Financial Statements**

March 31, 2019

3. Restricted Cash and Investments

Restricted cash and investments consists of cash and in investments in money market funds and corporate bonds which are restricted in their use and can only be used for specified purposes.

	2019	2018
Cash	\$ 114,211	\$ 853,656
Investments	764,803	122,325
	\$ 879,014	\$ 975,981

Restricted cash is allocated for the following purposes:

	2019	2018
Internally restricted funds (Note 9)	\$ 324,075	\$ 309,554
Replacement reserve funds (Schedule 1)	544,191	495,286
Gaming	-	119,931
Damage deposits	10,748	51,210
	\$ 879,014	\$ 975,981

4. Property, Plant and Equipment

	2019		2018	
	Cost	Accumulated Amortization	Cost	Accumulated Amortization
Land	\$ 2,782,085	\$ -	\$ 2,782,085	\$ -
Buildings	15,594,706	5,974,019	14,763,301	5,594,545
Vehicles	237,841	167,594	164,304	164,304
Computer equipment	71,740	63,076	68,697	60,620
Furniture and equipment	412,724	351,563	412,724	327,760
Leasehold improvements	61,370	60,217	61,370	55,246
	19,160,466	6,616,469	18,252,481	6,202,475
	\$ 12,543,997		\$ 12,050,006	

**Canadian Mental Health Association
Vernon and District Branch
Notes to Financial Statements**

March 31, 2019

5. Accounts Payable and Accrued Liabilities

Included in accounts payable and accrued liabilities are government remittances payable of \$11,982 (2018 - \$12,262).

6. Short Term Debt

	<u>2019</u>	<u>2018</u>
Royal Bank term loan, repayable in monthly instalments of \$1,265 including interest calculated at a rate of 3.58%, maturing November 2021.	<u>\$ 77,693</u>	<u>\$ 89,863</u>

**Canadian Mental Health Association
Vernon and District Branch
Notes to Financial Statements**

March 31, 2019

7. Long Term Debt

	2019	2018
MCAP Financial Corporation mortgage, with monthly principal and interest payments of \$25,434, with interest calculated at rates ranging between 2.20% and 4.12%, maturing between June 2021 and October 2027, secured by specific property.	\$ 3,916,316	\$ 4,121,828
Canada Mortgage and Housing Corporation mortgage, with monthly principal and interest payments of \$27,052, with interest calculated at a rate of 3.43%, maturing February 2021, secured by specific property.	2,774,924	3,000,828
Peoples Trust Company mortgage, with monthly principal and interest payments of \$1,674, with interest calculated at a rate of 3.46%, maturing March 2024, secured by specific property.	<u>330,340</u>	<u>338,925</u>
	7,021,580	7,461,581
Current portion	<u>(452,733)</u>	<u>(439,959)</u>
Long-term portion of debt	<u>\$ 6,568,847</u>	<u>\$ 7,021,622</u>

Principal repayments on long term debt over the next five years and thereafter are as follows:

2020	\$	452,733
2021		2,765,907
2022		315,414
2023		227,764
2024		515,844
Thereafter		<u>2,743,918</u>
	\$	<u>7,021,580</u>

**Canadian Mental Health Association
Vernon and District Branch
Notes to Financial Statements**

March 31, 2019

8. Deferred Capital Contributions

Albert Place

Contributions were received relating to capital improvements to the Albert Place building. These contributions have been deferred and are being amortized with the building additions over 40 years.

In December 2018, BC Housing provided a mortgage forgivable over a ten year period beginning in the first year of the mortgage. Monies were advanced in the March 31, 2019 fiscal year totaling \$19,348. At March 31, 2019, \$18,864 of the total \$19,348 in funding received is to be forgiven in future years.

Yin Ho

Contributions were received relating to capital improvements to the Yin Ho building. These contributions have been deferred and are being amortized with the building additions over 40 years.

In January 2019, BC Housing provided a mortgage forgivable over a ten year period beginning in the first year of the mortgage. Monies were advanced in the March 31, 2019 fiscal year totaling \$205,848. At March 31, 2019, \$202,417 of the total \$205,848 in funding received is to be forgiven in future years.

Deferred capital contributions represent the unamortized portion of contributed capital assets and restricted contributions used to purchase capital assets. The changes in the deferred capital contributions balance for the period are as follows:

	2019	2018
Beginning balance	\$ 1,803,590	\$ 1,462,030
Add: restricted contributions related to contributed equipment	909,877	413,900
Less: Amounts amortized to revenue	(97,089)	(72,340)
Ending balance	\$ 2,616,378	\$ 1,803,590

9. Internally Restricted Funds

The Association has reserved \$324,075 (2018 - \$309,553) for purposes of funding future purchases or replacement of equipment, furniture and other expenditures deemed necessary by management.

**Canadian Mental Health Association
Vernon and District Branch
Notes to Financial Statements**

March 31, 2019

10. Financial Instruments

Credit risk

Credit risk is the risk that one party to a financial instrument will cause a financial loss for the other party by failing to discharge an obligation. The Association is exposed to credit risk resulting from the possibility that a customer or counterparty to a financial instrument defaults on their financial obligations; if there is a concentration of transactions carried out with the same counterparty; or of financial obligations which have similar economic characteristics such that they could be similarly affected by changes in economic conditions. The Association's financial instruments that are exposed to concentrations of credit risk relate primarily to its accounts and contributions receivable. The majority of the Association's receivables are from government sources and the Association works to ensure it meets all eligibility criteria in order to qualify to receive the funding.

Liquidity risk

Liquidity risk is the risk that the Association will encounter difficulty in meeting its obligations associated with financial liabilities. Liquidity risk includes the risk that, as a result of operational liquidity requirements, the Association will not have sufficient funds to settle a transaction on the due date; will be forced to sell financial assets at a value, which is less than what they are worth; or may be unable to settle or recover a financial asset. The Association is exposed to this risk mainly in respect of its accounts payable, short term debt and long term debt.

Interest rate risk

Interest rate risk is the risk that the fair value or future cash flows of a financial instrument will fluctuate because of changes in market interest rates. The Association is exposed to interest rate risk on its fixed and floating interest rate financial instruments. Fixed interest instruments subject the Association to a fair value risk while the floating rate instruments subject it to a cash flow risk.

The Association mitigates interest rate risk on investments by diversifying the durations of the fixed-income investments that are held at a given time.

There have not been any changes in the risk from the prior year.

**Canadian Mental Health Association
Vernon and District Branch
Notes to Financial Statements**

March 31, 2019

11. Employee Pension Plan

The Association and its employees contribute to the Municipal Pension Plan (the "Plan"), a jointly trustee pension plan. The board of trustees, representing plan members and employers, is responsible for administering the Plan, including investment of the assets and administration of benefits. The Plan is a multi-employer defined benefit pension plan. Basic pension benefits provided are based on a formula. As at December 31, 2018, the Plan has about 197,000 active members and approximately 95,000 retired members. Active members include approximately 39,000 contributors from local government.

The most recent actuarial valuation as at December 31, 2015, indicated a \$2,224 million funding surplus for basic pension benefits. The next valuation will be December 31, 2018, with results available in 2019.

Employers participating in the plan record their pension expense as the amount of employer contributions made during the fiscal year (defined contribution pension plan accounting). This is because the plan records accrued liabilities and accrued assets for the plan in aggregate, resulting in no consistent and reliable basis for allocating the obligation, assets and cost to individual employers participating in the plan.

The Association paid \$186,476 (2018 - \$151,563) for employer contributions to the Plan in fiscal 2018.

12. Economic Dependence

The Association receives 54% (2018 - 55%) of its funding from the Province of British Columbia through the Interior Health Authority and BC Housing. The ability of the Association to continue operations is dependent upon continued funding from these sources.

13. Salaries, Honoraria and Benefits

During the year, the Association paid three employees (2018 - two) in excess of \$75,000. Total salaries, honoraria and benefits paid was \$261,267 (2018 - \$167,470). The Association does not provide remuneration to its Board of Directors.

14. Comparative Figures

Certain comparative figures have been reclassified to conform with the current year's financial statements presentation.

**Canadian Mental Health Association
Vernon and District Branch**

Schedule 1 - Statement of Changes in Replacement Reserve Fund

Under the terms of the operating agreements with BC Housing, the Replacement Reserve Funds are to be credited by the budget provision per annum plus interest earned. These funds along with accumulated interest must be held in a separate bank or investment savings accounts and can only hold instruments insured by the Canadian Deposit Insurance Corporation, the Credit Union Deposit Insurance Corporation, guaranteed by a Canadian government or in other investment instruments as agreed upon by BC Housing. The funds are to be used to replace major items that periodically wear out to ensure the building continues to be functional over its useful life.

	53rd Avenue	Albert Place	Belvedere Apartments	Group Home	Melrose Apartments	Yin Ho Gardens	2019	2018
Replacement Reserve, beginning of year	\$ 76,853	\$ 134,806	\$ 99,136	\$ 33,767	\$ 36,411	\$ 91,824	\$ 472,797	\$ 500,882
Replacement Reserve provision	36,288	15,352	14,688	6,048	5,184	37,152	114,912	99,360
Interest on replacement reserve	502	1,184	505	167	156	505	3,020	2,016
Repair and maintenance expenditures	(23,656)	(25,576)	(21,977)	(3,203)	-	(51,571)	(125,984)	(146,961)
Transfers to (from)	-	19,393	-	-	-	-	19,393	17,500
Replacement Reserve, end of year	\$ 89,987	\$ 145,359	\$ 92,352	\$ 36,779	\$ 41,751	\$ 77,910	\$ 484,138	\$ 472,797

**Canadian Mental Health Association
Vernon and District Branch
Schedule 2 - Statement of Revenues and Expenses - Programs**

For the year ended March 31	Main Operations	Housing Projects	2019	2018
Revenue				
Interior Health Authority	\$ 2,180,183	\$ -	\$ 2,180,183	\$ 2,019,090
Rent and user fees	306,924	761,856	1,068,780	1,040,065
BC Housing	-	726,012	726,012	628,346
Canadian Mental Health Association - BC				
Division	493,070	-	493,070	384,119
Donations and fundraising	223,552	-	223,552	173,914
Store sales	174,226	-	174,226	184,252
Grants	144,489	-	144,489	59,238
Sundry	67,287	32,745	100,032	71,975
BC Gaming	99,116	-	99,116	77,500
Workshop sales	97,508	-	97,508	94,878
United Way	5,535	-	5,535	7,535
BC Housing - Prior Year Subsidy Adjustment	-	(22,179)	(22,179)	(41,312)
Amortization of deferred contributions	28,149	68,940	97,089	72,340
	3,820,039	1,567,374	5,387,413	4,771,940
Expenses				
Advertising and promotion	24,500	-	24,500	20,580
Amortization	83,711	330,284	413,995	401,434
Insurance	7,171	23,831	31,002	32,063
Interest and bank charges	4,542	3,872	8,414	6,261
Interest on long term debt	3,012	209,933	212,945	204,299
Memberships and licenses	17,336	83	17,419	15,892
Office	52,313	11,524	63,837	43,187
Professional development	42,858	-	42,858	619
Professional fees	5,680	22,887	28,567	26,447
Program expenses	237,717	-	237,717	150,342
Property taxes	-	2,351	2,351	7,759
Rent	15,832	-	15,832	16,889
Repairs and maintenance	119,642	209,783	329,425	352,382
Subcontracts	42,935	1,188	44,123	17,591
Supplies	94,190	-	94,190	92,153
Telephone	-	4,240	4,240	20,828
Travel	19,653	4,647	24,300	17,510
Utilities	92,782	249,390	342,172	323,738
Vehicle	28,309	-	28,309	28,230
Volunteer and honorariums	79,741	-	79,741	76,677
Salaries, wages and benefits	2,914,230	250,335	3,164,565	2,772,176
	3,886,154	1,324,348	5,210,502	4,627,057
Excess (deficiency) of revenues over expenses	\$ (66,115)	\$ 243,026	\$ 176,911	\$ 144,883



ANNUAL GENERAL MEETING MINUTES 2018 – 2019

CMHA Vernon
Thursday, September 26, 2019

1. Call to Order:

Meeting was called to order at 5:04 pm by CMHA Vernon Board Chair, Richard Finn.
R. Finn welcomed the membership and invited each member of the Board to introduce themselves.
R. Finn offered regrets for absent Board members: B. Carscadden, T. Christensen and D. Penner.
R. Finn introduced ED., Julia Payson, who in turn, introduced the attending CMHA staff members.

2. Approval of Minutes for 2017-2018 Annual General Meeting:

MOTION: to approve the minutes of the AGM 2017-2018
Moved: J. Thom Seconded: T. Nolan Vote: Carried

3. Executive Director's Report: Julia Payson

J. Payson provided report covering the highlights of the past year:

- growth of programs and increase in engagement by the public
- growth of community awareness via media, school presentations and community events
- increase in funding through social enterprises, donations, grants and funding
- awarded BC Housing Project for an additional 30 unit
- new partnership and integration of Mental Illness Family Support Centre
- Okanagan College Leadership Skills Certificate for managers, team leaders and supervisors
- restructured leadership team to ensure holistic representation of all programs
- IT upgrade to Office 365 and higher level IT contractor to ensure security against cyber threat
- implementation of critical infrastructure supports through staffing and technology
- discussion of funding through donations, enterprises, grants and government funding
- community support through partnerships with Community Futures WorkBC and Men's Shed

MOTION: to accept the Executive Director's report as presented
Moved: J. Schneider Seconded: S. Delong Vote: Carried

4. President's Report: Richard Finn

R. Finn expressed appreciation for the work being done under the direction of J. Payson and the team of managers.

R. Finn expressed appreciation to the Board of Directors for their efforts in providing the work that is required to support the Executive Director and the organization. Linda MacKenzie, Executive Assistant, was recognized for her continuing support to the Board.

R. Finn informed the membership that the organization is in very good financial standing.

R. Finn indicated that the organization has secured insurance policies that meet the growing needs of CMHA Vernon and will ensure adequate coverage, if needed. Melody Irmen was recognized for her work in assisting the procurement of appropriate insurance coverage.

MOTION: to accept the Board President's report as presented
Moved: D. MacKenzie Seconded: M. Garcia Vote: Carried



5. Audited Financial Statement:

Financial Statement for the year ended March 31, 2019 was distributed for members review. BDO Canada representative Marcus Schrott reviewed the audited financial statement for 2018-2019, highlighted and compared the financial positions for 2018 and 2019. The Financial Statement 2018-2019 indicated that CMHA Vernon is in a good financial position for the coming year. R. Finn thanked BDO, for their work in ensuring a well-prepared financial statement.

MOTION: to accept the 2018 – 2019 Financial Statement as presented.

Moved: M. Garcia Seconded: D. Service Vote: Carried

6. Appointment of Auditor:

Appointment of auditor for the year 2019- 2020 was recommended to the membership.

MOTION: to contract BDO as auditors for the coming term of 2019 - 2020

Moved: M. Garcia Seconded: T. Nolan Vote: Carried

7. Appointment of Insurance Company:

Appointment of insurance company for the year 2019-2020 was recommended to the membership.

MOTION: to approve Marsh Insurance Canada as insurer for CMHA Vernon for the term of 2019 - 2020

Moved: T. Genest Seconded: D. MacKenzie Vote: Carried

8. Election of Board Members:

R. Finn read the names of the Board of Directors that required election or re-election by the membership.

Members requiring re-election:

Scott Delong

Members requiring election:

David Penner

James Schneider

Jodi Cunningham

MOTION: to approve the re-election and election of directors as presented

Moved: T. Genest Seconded: T. Nolan Vote: Carried

R. Finn recognized and appreciated the work done by retiring Board Members; Tanya Wick and Jay Hack



**Canadian Mental
Health Association**
Vernon & District
Mental health for all

9. Other Business:

1) Special Resolution: that the following changes be made to the By-Laws of the Society: that a number be added to the second paragraph of By-law 18.2 as highlighted and a phrase be added to By-law 19.1 as highlighted to read:

18.2.1 To further clarify Bylaw 18.2, the Canadian charitable organization(s) referred to in Bylaw 18.2 will have aims or purposes similar to those of this society. The Society will not alter or delete this Bylaw without first obtaining the written consent of the British Columbia Housing Management Commission.

19.1 The Society will not alter or delete the affordable housing purpose set out in paragraph 2(h) of its Constitution and the society will not alter or delete this bylaw without first obtaining the written consent of the British Columbia Housing Management Commission.

MOTION: to approve the changes to the By-Laws as presented
Moved: T. Genest Seconded: D. Service Vote: Carried

2) Mental Illness Family Support Services Presentation: Jenn Millan
J. Payson introduced J. Millan and expressed appreciation for the contribution that J. Millan and this program is making to the services of CMHA Vernon.
J. Millan explained that purpose of the program is to support families with members who are dealing with mental health issues. J. Millan introduced parents Laurie and Greg whose son deals with several different traumas and mental health issues. Laurie and Greg offered a comprehensive overview of the life they share with their son and the much-appreciated support that Mental Illness Family Support has provided their family.

10. Meeting Adjournment:

R. Finn thanked the membership for attending the AGM.
Meeting was adjourned at 6:15 pm



The Corporation of the City of Vernon

COUNCIL DISCRETIONARY GRANT APPLICATION FORM



IMPORTANT: *The deadline for Council Discretionary Grant Applications are semi-annual being April 30 and October 31 each calendar year.*

Applications will only be accepted during the intake periods of April 1 - April 30 and October 1 to October 31. Applications must be submitted to the Director of Financial Services no later than 4:00pm on the application deadline (April 30th and October 31st), if City Hall is closed that day, on the next working day that City Hall is open.

Applicants may run the risk of grant funding being depleted if waiting to apply until the October intake deadline.

If grant applications are received after the cut off periods they will be returned to the applicant and must be submitted at the next intake period.

Please note: Incomplete applications will not be considered

ORGANIZATION INFORMATION

NAME OF ORGANIZATION APPLYING FOR COUNCIL DISCRETIONARY GRANT:	The Dollywood Foundation of Canada
CONTACT PERSON:	Jessica Tanner - [REDACTED]
ORGANIZATION MAILING ADDRESS:	11 Waxwing Way, Brantford, Ontario, N3R 6W5
BUSINESS PHONE:	[REDACTED]
EMAIL ADDRESS:	[REDACTED]
REGISTERED NON PROFIT SOCIETY INCORPORATION NUMBER (required):	846742328RR0001

"Personal information contained on this form is collected under the *Freedom of Information and Protection of Privacy Act* and will be used only for the purposes of responding to your request".

City Hall Address: 3400 30th Street, Vernon BC, V1T 5E6
 Inquiries: 250-545-1361
 Web: www.vernon.ca



The Corporation of the City of Vernon

COUNCIL DISCRETIONARY GRANT APPLICATION FORM

ORGANIZATION GOALS, OBJECTIVES AND ACTIVITIES:

The Dollywood Foundation of Canada's early literacy, book gifting program, Dolly Parton's Imagination Library (DPIL), sends one book every month to the child's home from birth to age 5. The books are for all children, regardless of income and at no cost to the children or families. I am a mother of two young children and a nurse in our community. I want to start an Imagination Library in Vernon. DPIL strives to inspire children to love to read and to get as many books into the hands of children as possible.

SERVICE PROVIDED TO THE COMMUNITY:

Each registered child would receive a free, age appropriate book in the mail every month at no cost to them. DPIL has been shown to significantly increase the time parents and caregivers spend reading to their children each week. Children who are read to early in life are better prepared for school. Reading frequently to young children is one of the best tools caregivers and communities can provide to increase school readiness, to promote attachment and to strengthen parent child bonding.

A PROFILE AND HISTORY OF THE ORGANIZATION AND ITS ACCOMPLISHMENTS:

Please see attached.

PLEASE IDENTIFY THE STEPS YOUR ORGANIZATION HAS TAKEN TO ACQUIRE GRANTS FROM OTHER SOURCES:

I have applied online for other grants and funding and have been networking with other local groups involved with early learning programs. I have not received other funding yet.



The Corporation of the City of Vernon

COUNCIL DISCRETIONARY GRANT APPLICATION FORM

GRANT REQUEST

(You may wish to provide attachments, please note below where these items can be found.)

AMOUNT OF REQUEST:

\$9,033. For the first year, the program would need \$8,421 for the books and \$612 for 1,000 registration brochures. Please see attached 5 year projected funding summary for the Vernon area.

IN-KIND SERVICES: (please describe and include cost)

No in kind services yet, though I am hoping to receive some for advertising the program once I secure funding.

PURPOSE OF GRANT AND PROPOSED ALLOCATION OF FUNDS:

The grant money would pay for the books for the projected number of registered children for the first year. And it would pay for 1000 registration brochures for caregivers/parents to sign up the children.

BENEFITS TO COMMUNITY RESULTING FROM GRANT OR CITY GOALS AND OBJECTIVES THAT WILL BE MET, IF THE GRANT IS APPROVED:

This program directly benefits all children in our community as the program continues year to year, as well as the caregivers and eventually the community as a whole as those children grow up and become contributing members of our community.

DEGREE OF COMMUNITY FINANCIAL SUPPORT OR SPONSORSHIP:

I have not secured any other funding at this time but have applied and will be applying on other grants for current funding and continued funding to support the ongoing financial needs of the program.

City Hall Address: 3400 30th Street, Vernon BC, V1T 5E6

Inquiries: 250-545-1361

Web: www.vernon.ca



The Corporation of the City of Vernon

COUNCIL DISCRETIONARY GRANT APPLICATION FORM

DEGREE OF DEMONSTRATED ECONOMIC DEVELOPMENT, ENVIRONMENTAL STEWARDSHIP OR SOCIAL BENEFIT THAT MAY BE GENERATED BY THE AWARD OF A COUNCIL DISCRETIONARY GRANT:
 "A love of books and reading offers the foundation for literacy skills that set children up for future success." This program helps promote literacy, school readiness, and attachment, all important for children, families and our community. As a nurse, I have worked with families that do not read to their children, do not buy books, and do not own books for their children. I believe this program will open the door for every child to have that education, bonding and joy that reading bring.

GRANT QUALIFICATION CHECKLIST (please check all that apply):

- Community Based
- Providing a service which is not provided by any other group or organization within the City or which is provided for in another municipality and used by residents
- Must only submit one application per calendar year
- Grant request is not to cover retroactive funding or to cover a deficit

Note: Organizations do not qualify for the discretionary grant program if they are in receipt of regional funding or are receiving grants or other assistance from the City of Vernon.

GRANT REQUIREMENTS (please attach to your grant application):

- Most Recent Set of Financial Statements
- Minutes of Most Recent Annual General Meeting
- List of Members of the Executive (including positions held, address and contact numbers)

In the case of newly formed groups, a budget and information regarding the organization purpose including list of Board of Directors will be sufficient.

Oct. 31/19
Date
[Signature]
Signature

Funders & Policymakers



Inspire a Love of Reading



Dolly launched the Imagination Library to honor her father who was smart and hardworking, but never learned to read or write. The program is meant to give children from all walks of life, in Canada and around the world, a chance that Dolly's father never had.

Children ages birth-five who are registered with the program receive a free, age-appropriate book mailed to their home each month.

Dolly Parton believes that if you can read, you can do anything, dream anything, and be anything. Through her Imagination Library program, she wants to ensure all children have books at home, regardless of the environment in which they live.

Dolly Parton's Imagination Library puts books into the hands and hearts of children around the world. We partner with local communities to provide a free, high-quality book each month to registered children from birth to age five. The books are hand selected by a committee of early childhood experts to be age-appropriate and align with the child's developmental needs.



Books are personalized with the child's name and mailed directly to their home to create a gifting experience that makes books exciting and special.

A love of books and reading offers the foundation for literacy skills that set children up for future success. Dolly Parton's Imagination Library levels the playing field for all children by helping them build a home library of their very own and encouraging increased interaction with caregivers around books and reading.

"You can never get enough books into the hands of enough children."

Dolly



Dream More, Learn More, Care More, Be More

ImaginationLibrary.com



Helping Children Succeed & Communities Prosper

Improving early childhood literacy with Dolly Parton's Imagination Library creates opportunities for children to thrive so they succeed in school and help their communities grow and prosper.



1 Invest in books for children and families



2 Support local partners offering the program



3 Improve early literacy in your community

Dolly is investing in young children and hopes you will too.

The Dollywood Foundation covers program overhead by providing the custom-built Book Order System and coordinating the book selection, procurement, and fulfillment processes. In addition, the Dollywood Foundation purchases high-quality, customized books at scale, significantly reducing cost. With these contributions, our local partners are only required to cover the at-cost book and mailing expenses for children registered in their coverage area.

Funders and local partners facilitate the cost of providing books so there is no cost to children and families. This approach, along with the model that the program is available to all children and families in a covered area, helped Dolly Parton's Imagination Library receive a coveted **Best Practice Award** from the **U.S. Library of Congress** for addressing social barriers to literacy.

With funding and local community partnerships, the Imagination Library is able to provide an age-appropriate book each month to every child registered in the program, absolutely *free* to the family.

The average retail cost of Imagination Library titles is about \$16 per book. However, by purchasing in volume, the Imagination Library is able to acquire and mail customized titles for about \$3.55 per child per month.

How can you get involved?

- ✓ Help fund Dolly Parton's Imagination Library to promote literacy and a love of reading in your community.
- ✓ Utilize your position as a community leader to communicate Dolly Parton's Imagination Library value for children and families in your community.
- ✓ Connect with potential community partners to let them know you are interested in financially supporting Dolly Parton's Imagination Library locally.
- ✓ Organize other friends and colleagues to join in financially supporting Dolly Parton's Imagination Library for local children.
- ✓ Foster local Imagination Library research on books and literacy practices in the home.

The *Journal of the American Academy of Pediatrics* states that reading aloud to children at a young age can positively impact a child's brain development: When preschool children listen to stories, it activates the areas of their brains that are associated with processing images and narrative comprehension. It also exposes children to a larger, more diverse vocabulary and greater variety of sentence structures than just talking to them.

Imagination Library Simplified Funding Formula



**Example for community with 1,000 eligible children*





How It Works

At a Glance

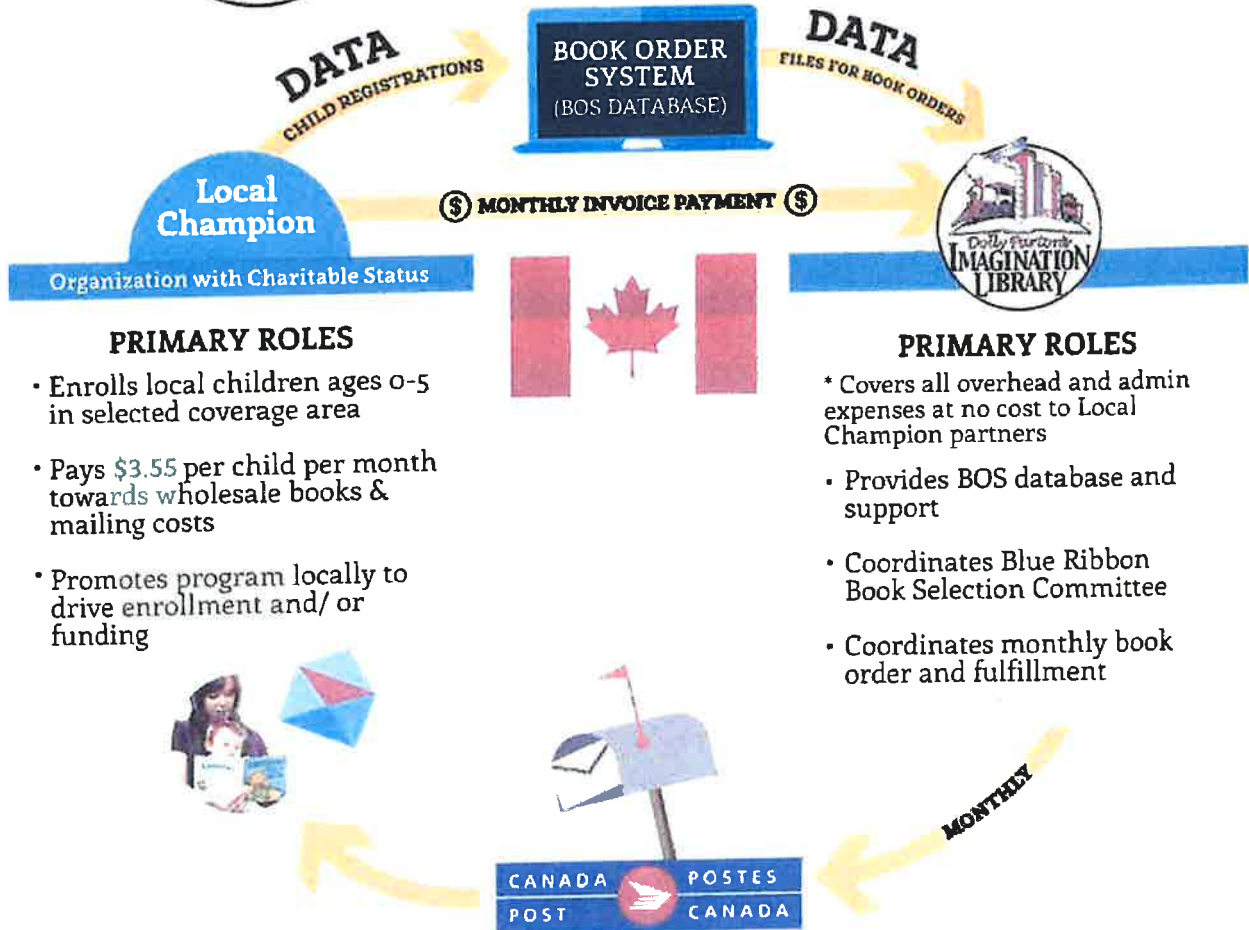

- Books arrive at child's home with name on the mailing label
- Program is free to families birth to age 5 children living in participating coverage areas





Dolly Parton's Imagination Library Summary of Research

Welcome to the Imagination Library

Imagination Library began with Dolly Parton's desire that every child, regardless of income, would have access to books. Since its founding, the Dollywood Foundation has conducted and encouraged research on the Imagination Library program in an effort to assess communities' reactions to the program and its impact on children's literacy. The majority of this research has been implemented at the local community level, by program staff or local researchers, to provide formative and summative feedback to support local Dolly Parton's Imagination Library (DPIL) implementations.

"We love the Imagination Library program! My daughter is so excited to get her new book each month. It supplements our trips to the public library and gets her excited about entering kindergarten as well."

The Dollywood Foundation initiated a review of over 20 years of research conducted on Imagination Library programs in the U.S. and internationally. The findings from the body of DPIL research indicate the program is extremely popular in the communities where it is implemented and show promise in promoting changes in home literacy environments, children's attitudes toward reading, and early literacy skills.



Positive Perceptions

- Participating family members were overwhelmingly positive about the program and its impact on their children when asked in questionnaires, interviews, and focus groups.
- Community members, including Imagination Library partners and preschool and kindergarten teachers, also had positive views of the program and its impact on book ownership and literacy practices in homes.
- The positive views of the program and its impacts were present regardless of the demographic characteristics of the community or its participants, and longer program participation often resulted in more positive outcomes.



Richer Home Literacy Environments

- Parents read aloud more to their children and were more comfortable reading as a result of DPIL.
- Parents reported their children owned more books as a result of participating in the program.



Dream More, Learn More, Care More, Be More

ImaginationLibrary.com





Improving Attitudes and Skills

- Parents believed their children were more interested in reading due to receiving the books each month.
- Participating children were excited when their DPIL books arrived in the mail monthly, addressed specifically to the child.
- Some studies found DPIL had promise with respect to developing children's early literacy skills, as participants had more advanced skills than their classmates who did not participate in the program.



Logic Model

The Dollywood Foundation is committed to supporting local DPIL programs and communities. One focus of our recent work has been identifying common outcomes for all DPIL programs. This will ensure we are all on the same page and provide the best program possible for children and families. These research-based outcomes were identified through reviews of the literature and are considered to be building blocks for lifelong literacy, supported by the research, and aligned with DPIL's philosophy and goals.

Imagination Library strives to...

Enhance participants' home literacy environments so that...

- ✓ Books are available in homes
- ✓ Caregivers begin reading to children early in life
- ✓ Caregivers read to children frequently and for increasing amounts of time as they age

Promote positive attitudes and increased motivation to read so...

- ✓ Children ask adults to read to them
- ✓ Children "play" with books independently

Increase the number of interactions between caregivers and children during reading so...

- ✓ Children respond and contribute to book reading
- ✓ Children practice reading skills

Such that children develop emerging literacy skills including...

- ✓ Understanding print conventions
- ✓ Naming letters and making letter sounds
- ✓ Increasing their vocabulary
- ✓ Understanding oral sounds, syllables, and words
- ✓ Improving auditory memory



Dolly Parton's Imagination Library

Summary of Research

Logic Model (continued)

The Dollywood Foundation is committed to guiding and assisting community-based DPIL programs to provide the best experience for all participants. The Foundation will support both beginning and existing community-based DPIL programs by providing resources to help organizations...

- ✓ Plan how to research and evaluate the program
- ✓ Establish partnerships with local researchers
- ✓ Become familiar with the research on DPIL and what lessons were learned
- ✓ Use the Dollywood Foundation's resources and guidance to communicate effectively with researchers and other community stakeholders
- ✓ Conduct innovative research to assess DPIL's identified outcomes

The Foundation looks forward to continuing our work supporting rigorous research on Imagination Library in existing and new DPIL communities. Through this research, we can continue to expand Dolly's vision of ensuring every child is exposed to the magic of books!

Logic Model

Based on Imagination Library Research Findings and Literature Review.

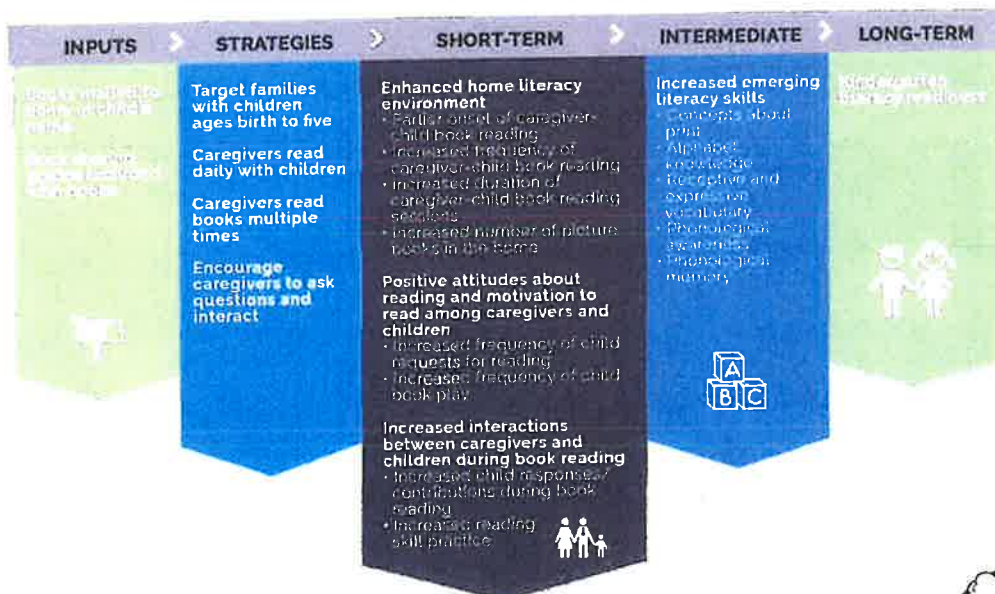

For information and program details, please visit ImaginationLibrary.com.



Awards & Milestones

Program Awards

Together, Dolly Parton and her book gifting organization have received honors and awards for their dedication to enriching the lives of children everywhere. The Good Housekeeping Seal of Approval, Best Practices award from the Library of Congress Literacy Awards and recognition in Reading Psychology are among a few of the prestigious acknowledgments the program has received.

- **2000** – Association Of American Publishers Honors Award From Association Of American Publishers
- **2001** – Good Housekeeping Seal Of Approval
- **2003** – Child And Family Advocacy Award From Parents As Teachers National Center
- **2012** – Imagination Library Recognized In The Academic Journal, Reading Psychology, For “increasing Parental Reading Through Book Distribution.”
- **2014** – Best Practices From The Library Of Congress Literacy Awards

Program History

1995 – Entertainment icon and savvy businesswoman, Dolly Parton, founded the Imagination Library. She was inspired by her [father's inability to read](#) or write. The program started as a local effort in Dolly's home, Sevier County, Tennessee. In hopes of inspiring a love of reading and learning from a young age, the program mails one free, age-appropriate book to registered children each month. The first book order totaled 1,760 books.

2000 – A national replication effort began to expand the program's reach beyond Sevier County, Tennessee.

2001 – Dolly Parton's Imagination Library saw program expansion with 27 affiliates operating in 11 states across the nation. Local sponsors around the country came forward to support the program's expansion, including Spartanburg, Sioux Falls and Sioux City, which seeded the program within their United Way organizations. These new communities mailed books to almost 30,000 children under the age of five, proving that dreams really do come true.

2002 – United Way organizations helped Imagination Library reach thousands of children in Native American communities throughout the US. Preschoolers in 92 Native American communities would become recipients of Imagination Library books.

2003 – The organization sent their one millionth free book! The milestone symbolized not only what had been accomplished so far, but also showed the promise of even more valuable opportunities for the future of Imagination Library.

2004 – Phil Bredesen, Governor of Tennessee, pledged to provide Dolly Parton's Imagination Library program to every child under five across the entire state. For the first time, an entire state guaranteed that every child within its borders will have access to quality books and the joy they inspire.

2005 – An International Book Committee was formed to choose age-appropriate books for Imagination Library. With the help of Penguin Group USA, the newly

formed committee selected the book titles to ensure every child received the best books possible. This move was the first step in transitioning into an international organization. Soon Imagination Library would extend into Canada followed by the United Kingdom and Australia.

2006 – Dolly bounced on a stage in Toronto to announce that the Imagination Library will now be available to children in Canadian communities. For the first time, the program crossed an international border with the goal to make the program Canada’s own unique attempt to instill a love for reading in all of her children.

2007 – In a special visit to London, Dolly announced that her Imagination Library would now be available to communities throughout the United Kingdom. In addition, Dolly’s Imagination Playhouse, featuring the Penguin Players, not only performed daily at Dollywood through the summer, it also brought the show on the road, performing over 70 times to over 4,000 kids.

2008 – Almost 5.5 million books were mailed and the total mailed since program inception soared to 17.1 million books!

2009 – In the United Kingdom, the 100,000th book was distributed, and in Canada the number of children participating each month increased by over 100%. Partnerships with Rotary International and United Way were announced in March and June respectively.

2010 – Dolly presented the 25 millionth Imagination Library book and by the end of the year the 30 millionth book had been mailed.

2011 – The Imagination Library announced a partnership with The American Printing House for the Blind. Audio versions of many of the Imagination Library books were created for children with visual impairments.

2012 – Following the success of the audio books, some Imagination Library books will be made available in Braille. Furthermore, the research article based on DPIL (by the extraordinary team from Le Moyne College) was accepted for publication in the journal, Reading Psychology.

2013 – Dolly’s Imagination Library Expands To Australia after a partnership with the United Way led to a pilot effort with several communities which ultimately launched a national program.

2014 – The Imagination Library received the Best Practices Award from The Library Of Congress Literacy Awards

2015 – The 20th anniversary culminated with a record-breaking performance that both extended and deepened the program across the world. The Book Selection Committee chose 12 bilingual Spanish titles for the USA and 10 new titles with more specific Canadian content. In addition, the pre-sales began for the Dolly Parton License Plate in Tennessee.

2016 – The program celebrated the “One Million A Month” milestone at Dolly’s sold-out concert benefiting the Imagination Library. In addition, a pilot program in Belize received over 19,000 Imagination Library books. Also, The Dolly Parton License Plate was approved for sales in Tennessee.

For Vernon, BC
as per Census Profile
2016.



TOTAL ELIGIBLE
POPULATION UNDER 5
2640

BUDGETED POPULATION
(60% OF ELIGIBLE)
1584

COST OF BOOKS AND
MAILING PER CHILD
\$3.55

**THE EXPENSES BELOW REFLECT THE CORRESPONDING PERCENTAGE OF THE
BUDGETED POPULATION**

	Registered Population	YEAR 1	Registered Population	YEAR 2	Registered Population	YEAR 3	Registered Population	YEAR 4	Registered Population	YEAR 5
Mth 1	5%	\$281	20%	\$1,125	40%	\$2,249	60%	\$3,374	80%	\$4,499
Mth 2	6%	\$358	22%	\$1,227	42%	\$2,352	62%	\$3,476	82%	\$4,601
Mth 3	8%	\$434	24%	\$1,329	44%	\$2,454	64%	\$3,579	84%	\$4,703
Mth 4	9%	\$511	25%	\$1,432	45%	\$2,556	65%	\$3,681	85%	\$4,806
Mth 5	10%	\$587	27%	\$1,534	47%	\$2,659	67%	\$3,783	87%	\$4,908
Mth 6	12%	\$664	29%	\$1,636	49%	\$2,761	69%	\$3,886	89%	\$5,010
Mth 7	13%	\$740	31%	\$1,739	51%	\$2,863	71%	\$3,988	91%	\$5,113
Mth 8	15%	\$816	33%	\$1,841	53%	\$2,966	73%	\$4,090	93%	\$5,215
Mth 9	16%	\$893	35%	\$1,943	55%	\$3,068	75%	\$4,193	95%	\$5,317
Mth 10	17%	\$969	36%	\$2,046	56%	\$3,170	76%	\$4,295	96%	\$5,420
Mth 11	19%	\$1,046	38%	\$2,148	58%	\$3,273	78%	\$4,397	98%	\$5,522
Mth 12	20%	\$1,122	40%	\$2,250	60%	\$3,375	80%	\$4,500	100%	\$5,624
		\$8,421		\$20,250		\$33,746		\$47,242		\$60,738



Jeanne Smitiuch
Regional Director, Canada
Dolly Parton's Imagination Library
519-771-2543 | jsmitiuch@imaginationlibrary.ca
www.imaginationlibrary.ca
11 Waxwing Way, Brantford, Ontario N3R 6W5



The Corporation of the City of Vernon

COUNCIL DISCRETIONARY GRANT APPLICATION FORM



IMPORTANT: The deadline for Council Discretionary Grant Applications are semi-annual being April 30 and October 31 each calendar year.

Applications will only be accepted during the intake periods of April 1 - April 30 and October 1 to October 31. Applications must be submitted to the Director of Financial Services no later than 4:00pm on the application deadline (April 30th and October 31st), if City Hall is closed that day, on the next working day that City Hall is open.

Applicants may run the risk of grant funding being depleted if waiting to apply until the October intake deadline.

If grant applications are received after the cut off periods they will be returned to the applicant and must be submitted at the next intake period.

Please note: Incomplete applications will not be considered

ORGANIZATION INFORMATION

NAME OF ORGANIZATION APPLYING FOR COUNCIL DISCRETIONARY GRANT:	Benevolent & Protective Order of Elks of Canada; Lodge #45 (Vernon)
CONTACT PERSON:	Maureen Sather; Secretary/Treasurer
ORGANIZATION MAILING ADDRESS:	3103 - 30th Street Vernon, BC V1T 5E3
BUSINESS PHONE:	250 549 1883
EMAIL ADDRESS:	elks45@telus.net
REGISTERED NON PROFIT SOCIETY INCORPORATION NUMBER (required):	S-41630
Website Facebook page	Website: www.vernonelks.com Facebook: @elkslodge45

"Personal information contained on this form is collected under the *Freedom of Information and Protection of Privacy Act* and will be used only for the purposes of responding to your request".

City Hall Address: 3400 30th Street, Vernon BC, V1T 5E6
Inquiries: 250-545-1361
Web: www.vernon.ca



The Corporation of the City of Vernon COUNCIL DISCRETIONARY GRANT APPLICATION FORM

ORGANIZATION GOALS, OBJECTIVES AND ACTIVITIES:

The Vernon Elks Lodge established on March 30, 1920 will have been a fixture of Vernon for 100 years. Our Vision is, "to become the most progressive family focused organization in Canada, meeting community and members' needs and expectations in effective and innovative ways."

We offer weekly recreational activities and a dinner for community members. Monthly dances and performances are also held at the lodge. Annually we host pancake breakfasts and our community garage sale. Vernon Elks are actively involved in community events such as the Vernon's Winter Carnival, Military Tattoo, Interior Provincial Exhibition and fundraising activities for other not for profits, with a special focus on children & youth. Over 95% of participants of events and activities are community members and not Elks Lodge members. Approximately 10 small community groups and organizations participate in the volunteer opportunities at the lodge during the community dinner on Friday evenings.

SERVICE PROVIDED TO THE COMMUNITY:

See attachment appendix 'A'

A PROFILE AND HISTORY OF THE ORGANIZATION AND ITS ACCOMPLISHMENTS: For the past 99 years Elks Lodge #45 has remained an intricate part of our community. The Elks Lodge does not exist for the purposes of its members but solely for the benefit of the community placing a special emphasis on programs & services for children. Many special memories have been made at the lodge. It offers a relaxed atmosphere where the community can socialize and share recreation with others. The lodge is an ideal place for weddings, celebrations of life, fundraising events, and community events. The Vernon Elks have a long history of supporting families in need. We have donated our venue to families in need to help raise money to support the high cost of medical travel and treatment. We have provided hearing aids to children whose families otherwise cannot afford them. The tradition of the Friday Night Meal Program has helped families for 89 years by providing an affordable and nutritious meal. The volunteer program provides a way for community members and groups to contribute to their community while supporting programs & services.

PLEASE IDENTIFY THE STEPS YOUR ORGANIZATION HAS TAKEN TO ACQUIRE GRANTS FROM OTHER SOURCES:

Elks Lodge No.45 submitted an application to the Government of Canada – New Horizons for Seniors for a grant in toward replacement of the 2 furnaces (over 30 years old) and to BC Gaming for replacement of lighting, which will increase energy efficiency. We have not received a response at this time whether the funding has been approved. The Elks Lodge is unable to apply to United Way or Community Foundation as we are not a registered charity. The support of the City of Vernon is critical to the success of our ongoing programs and services.

City Hall Address: 3400 30th Street, Vernon BC, V1T 5E6

Inquiries: 250-545-1361

Web: www.vernon.ca



The Corporation of the City of Vernon

COUNCIL DISCRETIONARY GRANT APPLICATION FORM

GRANT REQUEST

(You may wish to provide attachments, please note below where these items can be found.)

<p><u>AMOUNT OF REQUEST: \$10,000</u></p>
<p><u>IN-KIND SERVICES: (please describe and include cost)</u> The Vernon Elks Lodge #45 does not have any paid positions and would not be able to operate without the selfless dedication of our volunteers who are involved in every aspect of our daily operations and activities. Volunteer activities include, but are not limited to: cooking, cleaning, set-up and take-down, shopping, volunteer coordination, booking events, bookkeeping, and coordinating special events. Exclusive of special events our volunteers donate an average of 540 hours of their time each month. 540 (hours per month) X 12 months = 6,480 (hours per year) X \$11.35 (minimum wage) = \$73,548.00 per year. Elks Volunteers also contribute to community events such as the Vernon RibFest, Military Tattoo, Winter Carnival etc.</p>
<p><u>PURPOSE OF GRANT AND PROPOSED ALLOCATION OF FUNDS:</u> This application is specific to purchasing a new piece of kitchen equipment a meat slicer and for replacement of the tables. Below is a list of equipment that is necessary to continue the activities 1) Rectangle Table Replacement The Elks Lodge is in dire need of replacing the 25 rectangle tables. The current tables are in very poor repair, due to excessive use (setting up and taking down for storage). Currently, we do our best to maintain & repair the tables. The table finishes are dull & peeling, they look filthy even though they are regularly cleaned. The edges are badly scuffed, worn, & very rough. The folding mechanics are worn, stiff & extremely difficult to open and close. The bracket between the table legs & the table top are wiggly, causing them to be rocky & insecure. We are concerned that the tables may not hold up under the weight they are required to hold as well as they have become increasingly difficult for our senior volunteers to set up and take down.</p>
<p><u>BENEFITS TO COMMUNITY RESULTING FROM GRANT OR CITY GOALS AND OBJECTIVES THAT WILL BE MET, IF THE GRANT IS APPROVED:</u></p> <p>See attachment Appendix 'B'</p>
<p><u>DEGREE OF COMMUNITY FINANCIAL SUPPORT OR SPONSORSHIP:</u></p> <p>See letters of support</p>

City Hall Address: 3400 30th Street, Vernon BC, V1T 5E6
Inquiries: 250-545-1361
Web: www.vernon.ca



The Corporation of the City of Vernon

COUNCIL DISCRETIONARY GRANT APPLICATION FORM

DEGREE OF DEMONSTRATED ECONOMIC DEVELOPMENT, ENVIRONMENTAL STEWARDSHIP OR SOCIAL BENEFIT THAT MAY BE GENERATED BY THE AWARD OF A COUNCIL DISCRETIONARY GRANT:

This project will update lighting to energy saving products as well as save energy costs on an ongoing basis while contributing positively to the sustainability of the environment. It also takes advantage of incentives offered by BC Hydro.

GRANT QUALIFICATION CHECKLIST (please check all that apply):

- ✓ Community Based
- ✓ Providing a service which is not provided by any other group or organization within the City or which is provided for in another municipality and used by residents
- ✓ Must only submit one application per calendar year
- ✓ Grant request is not to cover retroactive funding or to cover a deficit

Note: Organizations do not qualify for the discretionary grant program if they are in receipt of regional funding or are receiving grants or other assistance from the City of Vernon.

GRANT REQUIREMENTS (please attach to your grant application):

- ✓ Most Recent Set of Financial Statements
- ✓ Minutes of Most Recent Annual General Meeting
- ✓ List of Members of the Executive (including positions held, address and contact numbers)

In the case of newly formed groups, a budget and information regarding the organization purpose including list of Board of Directors will be sufficient.

October 30, 2019

Date

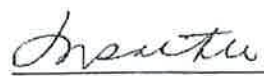

Signature

City Hall Address: 3400 30th Street, Vernon BC, V1T 5E6
Inquiries: 250-545-1361
Web: www.vernon.ca

SERVICE PROVIDED TO THE COMMUNITY:

The Friday Night Supper program has been offered by the Elks Lodge for the last 89 years (from Sept - June). The multi-course dinners are hot and nutritious. Many participants are seniors, persons with disabilities, some of whom find it difficult to shop for food or to prepare hot meals. The Friday Night Dinner is offered at a reduced cost and additional meals can be purchased and taken home for another day. Over 95% of the Friday Night Dinner Program participant are community members and are not otherwise affiliated with the lodge.

This service provides an opportunity to gather together and socialize for individuals that are often isolated or experience loneliness. The Lodge provides a sense of belonging, a sense of purpose and increases the quality of the lives of both the participants and the volunteers.

The Lodge Banquet Hall is home to provide opportunities for the Ukrainian Dancers (children and youth) to perform for the crowd. The semi-annual performances by the dancers compliment The Ukrainian Dinner and the interaction between the seniors, children, and youth is heartwarming. This intergenerational event is one of the best attended activities.

The Volunteer Opportunities Program works together with organizations such as Vernon Treatment Centre where individuals in recovery from addictions can work in a kitchen environment to develop job and social skills. Successful volunteers, upon request, can receive letters of recommendation and reference that they can use toward securing a paid position.

The Elks Lodge Community Donation Program provides a small donation to community groups and not for profit organizations (mostly children and youth programs) in exchange for volunteering. The purpose of this service is multi-fold; Children, Youth and Young families experience firsthand the value of contributing to others in the community; Children and Youth have opportunities to participate in activities that they would not be able to otherwise ex: attend kids camp or join an activity of interest; The Elks Lodge has invested volunteers to share in the work as well as to sustain the programs into the future.

BENEFITS TO COMMUNITY RESULTING FROM GRANT OR CITY GOALS AND OBJECTIVES THAT WILL BE MET, IF THE GRANT IS APPROVED:

Benefits to the Community:

Vernon Elks Lodge #45 is historically and currently one of Vernon's most central gathering places. It is the only hall available in the city centre proper. In addition to recreational and social gatherings, the lodge is a key provider of affordable meals in the community. Purchasing a meat slicer will improve the food program and the ease of use for our senior volunteers. We will be able to prepare the food more quickly and efficiently and will be able to ensure consistency to the meals for those who need them.

City Goals:

Foster Community Development through Social Planning

- Continue to support the City of Vernon's community development through social planning services to the City, including programs and initiatives to address homelessness, childcare, attainable housing, food security and neighbourhood safety.
- The Elks Lodge contributes to Food Security by providing a full Friday Night Meal. Cooking with a meat slicer has many operational and health benefits. It is such an efficient method of plating food.

Work with community groups and agencies to support youth and senior oriented initiatives

- Elks Lodge #45 has several programs oriented to seniors. Pool, shuffleboard, card games, dances, and darts are just a few of activities that seniors have come to expect.
- The Ukrainian Dancers and multiple organizations use the lodge to meet and/or learn new skills.

Minutes of the May 21st 2019 Elks Annual General Meeting

The Meeting was called to order by ER Wm McDonald at 5:05 pm

Roll Call 4 officers 13 members 1 visitor

Reading of Minutes: M.Sather read the minutes of the previous meeting. As there were no errors or omissions it was Moved & Seconded by Sue Camponi & Heinz Schar to accept minutes as read, AIF

Correspondence: Cards of thanks were read from 4 people who received bursaries.

Treasurers Report: Moe advised Management A/C -915.91 Reno A/C \$5864.72 Gaming A/C \$23513.47 It was Moved & Seconded by Sue Camponi & Laverne Francis to accept report as read. AIF

Other reports – Back Door now fixed. Breakfast are over for the summer.

Reading of New Members – no new member to report

New Business: - no new business

Good of the Order: We will hold vote for Directors Election. The people who will stand are listed:
Ex. Ruler Wm McDonald- Sec/Treasurer Maureen Sather- Loyal Knight Murray Wosnick – Leading Knight Bob Montgomery- Lecturing Knight Bob Hill – Esquire – Heinz Schar -chaplin Annetta Herzog

The ballots were counted by Wm McDonald & Maureen Sather. All in favor – Carried.
There was a motion to destroy all ballots by Maureen Sather -seconded by Sue Camponi. All in favor Carried. List of Directors/ Officers for 2019/2020

Exalted Ruler	Wm McDonald
Secretary/Treasurer	Maureen Sather
Loyal Knight	Murray Wosnick
Leading Knight	Bob Montgomery
Lecturing Knight	Bob Hill
Esquire	Heinz Schar
Chaplin	Annetta Herzog

Attendance 4 officers 13 members 1 visitor

The meeting was closed at 6:30

Wm. McDonald.......... Maureen Sather..........

Elk's Lodge#45

Income Statement 01/01/2018 to 12/31/2018

REVENUE

Lodge Revenue	
Membership Dues	670.00
Total Lodge Income	670.00

Income	
Hall rentals	12,360.00
Keno Commissions	3,357.75
Liquor Sales	50,917.81
Bottle Refund	230.15
Dinner Sales	46,416.00
Lottery Sales	515.00
Miscellaneous Revenue - Lodge	24,743.00
PST Commission	232.80
Pull Tab Income	469.00
Total Management Revenue	139,261.51

Other Revenue	
Miscellaneous Revenue	25.61
Total Other Revenue	25.61

TOTAL REVENUE 139,957.12**EXPENSE**

Lodge Expenses	
Per Capita Dues	1,666.49
Regalia	72.87
Total Lodge Expenses	1,739.36

Gaming Expenses	
Gamin Licences	75.00
Total gaming Expenses	75.00

Cost of goods Sold	
Liquor Purchases	32,632.91
Dinner Costs & Supplies	29,341.22
Lottery Purchases	587.62
Social Event Expense	2,024.84
Total Cost of Goods Sold	64,586.59

General & Administrative Expe..	
Bookkeeping Expense	1,253.33
Administration	2,819.05
Advertising & Promotions	79.40
Birthday supplies	140.64
Bar Supplies	4,582.11
Car Allowance	1,756.83
Hall Expenses	2,378.63
First Data Corp.	524.16
Janitor & Supplies	4,234.82
Keno Administration	493.35
Kitchen Supplies & Equip.	1,088.68
Insurance	7,251.60
Interest & Bank Charges	939.25
Laundry	1,188.69
Legal Expenses	263.81
Office Supplies	1,358.29
Permits and Licenses	270.00
Property Taxes	4,909.29
Repair & Maintenance	34,528.94
Security	819.00
Telephone	2,970.39

Printed On: 05/27/2019

Elk's Lodge#45

Income Statement 01/01/2018 to 12/31/2018

Tickets	343.83
Utilities - Hydro	4,241.39
Utilities - Fortis	2,472.76
Utilities - Shaw	1,083.23
Utilities - Water/Sewer	1,341.28
Utilities - Waste Management	1,019.85
Winter Carnival Expenses	1,019.85
Total General & Admin. Expen...	85,171.75
TOTAL EXPENSE	151,652.70
NET INCOME	43,505.58

Printed On: 06/27/2019

Elk's Lodge#45
Balance Sheet As at 12/31/2018

ASSET

ASSET ACCOUNTS

Junk Account		300.00
Upstairs Bar Float		1,450.00
Cash - Safe		665.00
Downstairs Float		5,879.05
Management Account - VOCL		35.97
Class A Membership Equity		11,591.33
Credit Union - Reno Acct.		19,623.17
Total Assets		

Inventory Assets

Liquor Inventory_		8,500.00
Lottery Tickets		2,000.00
Other Inventory_		1,500.00
Total Inventory Assets		10,000.00

Capital Assets

Leasehold Improvements	32,918.38	
Accum. Amort.-Leasehold Impro...	-3,374.92	
Net-Leasehold Improvements		23,041.46
Office Furniture & Equipment	84,077.83	
Kitchen Equipment	3,662.37	
Accum. Amort.-Fum & Equip.	-73,759.24	
Net - Furniture & Equipment		13,980.96
Building	182,000.00	
Accum. Amort.-Building	-30,250.00	
Net - Building		151,750.00
Land		241,000.00
Renovations - Grant		-40,747.77
Computer 2008	568.71	
Accum. Amort-Computer2008	-568.71	
Net-Computer2008		0.00
Total Other Assets		389,037.85

TOTAL ASSET 418,660.82

LIABILITY

Current Liabilities

Account Payable		22,680.00
New Horizon's Grant		9,588.00
L.Tax		751.58
HST Rec'd on Sales	2,683.77	
GST/HST Paid on Purchases	-3,967.42	
Net GST (Owing) or Refund		-1,283.65
Total Current Liabilities		30,649.93

TOTAL LIABILITY 30,649.93

EQUITY

Owners Equity

Retained Earnings - Previous Year		389,606.47
Current Earnings		-1,945.58
Total Owners Equity		388,010.89

TOTAL EQUITY 388,010.89

LIABILITIES AND EQUITY 418,660.82

Printed On: 06/27/2019

Elk's Lodge#45

Trial Balance As at 12/31/2018

Ac...	Account Description	Debits	Credits
1020	Junk Account	-	98.18
1030	Till	0.00	-
1035	Upstairs Bar Float	300.00	-
1040	Cash - Safe	1,450.00	-
1045	Downstairs Float	665.00	-
1050	Petty Cash	0.00	-
1060	Management Account - VCCU	5,679.05	-
1061	Class A Membership Equity	35.97	-
1065	Gaming Account - HSBC	0.00	-
1068	Gaming - Investment Acct. - HSBC	0.00	-
1089	Credit Union - Reno Acct	11,591.33	-
1200	Accounts Receivable	0.00	-
1230	Intercompany Loan - Charity Acc...	0.00	-
1520	Liquor Inventory_	5,500.00	-
1535	Lottery Tickets	2,000.00	-
1540	Other Inventory_	1,500.00	-
1810	Leasehold Improvements	32,918.38	-
1811	Accum. Amort.-Leasehold Impro...	-	9,874.92
1820	Office Furniture & Equipment	84,077.83	-
1821	Kitchen Equipment	3,862.37	-
1825	Accum. Amort. -Furn. & Equip.	-	73,750.24
1860	Building	182,000.00	-
1865	Accum. Amort. -Building	-	30,250.00
1880	Land	241,000.00	-
1883	Renovations - Grant	-	40,743.77
1895	Computer 2008	568.71	-
1896	Accum. Amort-Computer2008	-	568.71
1910	Computer Software	0.00	-
1920	Goodwill	0.00	-
2100	Account Payable	-	22,680.00
2120	Bank Loan - Current Portion	-	0.00
2125	Due to BCLC	-	0.00
2128	Loan to Charity Act - Intercompany	-	0.00
2127	Loan to Reno Acct.	-	0.00
2130	New Horizon's Grant	-	9,598.00
2140	Credit Card Payable	-	0.00
2160	Corporate Taxes payable	-	0.00
2200	Lounge in/out account	-	0.00
2300	PST Payable	-	0.00
2305	LTax	-	751.68
2310	HST Rec'd on Sales	-	2,583.77
2315	GST/HST Paid on Purchases	5,063.42	-
2320	GST/HST Owing	-	0.00
2620	Bank Loans	-	0.00
2625	Loan - Lodge Acct	-	0.00
2630	Mortgage Payable	-	0.00
2640	Loans from Owners	-	0.00
3010	Owners Contribution	-	0.00
3015	Owners Withdrawals	-	0.00
3580	Retained Earnings - Previous Year	-	398,806.47
4020	Membership Dues	-	670.00
4030	Regale	-	0.00
4203	Administration from Gaming	-	0.00
4205	Crib Income	-	0.00
4206	Flea -USE 4220	-	0.00
4210	Hall rentals	-	12,360.00
4212	Keno Commissions	-	3,357.75
4215	Liquor Sales	-	90,917.81
4217	Bottle Refund	-	230.16
4225	Dinner Sales	-	46,416.00
4230	Lottery Sales	-	515.00
4240	Social Event Revenue	-	0.00
4280	Miscellaneous Revenue - Lodge	-	24,743.00
4285	PST Commission	-	232.80
4270	Pull Tab Income	-	489.00

Printed On: 06/27/2019

Elk's Lodge#45

Trial Balance As at 12/31/2018

Ac.	Account Description	Debits	Credits
4420	Freight Revenue		0.00
4440	Interest Revenue		0.00
4460	Miscellaneous Revenue		25.61
5020	Per Capita Dues	1,888.49	
5030	Regalia	72.87	
5040	Conference Expenses	0.00	
5050	Dinner & Travel	0.00	
5130	Administration Exp DO NOT USE	0.00	
5132	Garmin Licences	75.00	
5210	Liquor Purchases	32,632.91	
5220	Cigarette Purchases	0.00	
5225	Crib Expenses	0.00	
5230	Dinner Costs & Supplies	29,341.22	
5240	Food/Pop Purchases	0.00	
5245	"Litter Deposits "SEE 4217"	0.00	
5250	Lottery Purchases	567.82	
5260	Lottery Payouts	0.00	
5265	Cash Over/Under	0.00	
5270	Social Event Expense	2,024.84	
5300	Freight Expense	0.00	
5310	Delivery	0.00	
5610	Bookkeeping Expense	1,253.33	
5612	Administration	2,819.05	
5614	Accum. Depreciation	0.00	
5615	Advertising & Promotions	79.40	
5618	Anniversary 86th Expense	0.00	
5620	Bad Debts	0.00	
5630	Bands	0.00	
5635	Birthday supplies	140.84	
5640	Bar Supplies	4,562.11	
5641	Cash Over/Short	0.00	
5642	Debit Machine	0.00	
5643	Car Allowance	1,758.83	
5644	Social USE 4270	0.00	
5645	Hall Expenses	2,378.63	
5650	First Data Corp_	524.16	
5660	Jenitor & Supplies	4,234.82	
5685	Keno Administration	493.35	
5670	Kitchen Supplies & Equip.	1,088.68	
5680	meat - USE 5135	0.00	
5686	Insurance	7,251.60	
5690	Interest & Bank Charges	939.25	
5695	Laundry	1,188.68	
5697	Legal Expenses	263.81	
5700	Office Supplies	1,358.28	
5710	Permits and Licenses	270.00	
5715	Prizes	0.00	
5720	Property Taxes	4,809.29	
5740	Miscellaneous	0.00	
5760	Lease Equipment	0.00	
5785	Repair & Maintenance	34,528.94	
5768	Security	618.00	
5780	Telephone	2,970.39	
5762	Tickets	343.93	
5785	Travel & Entertainment	0.00	
5790	Utilities - Hydro	4,241.39	
5762	Utilities - Fortis	2,472.76	
5795	Utilities - Shaw	1,083.23	
5796	Utilities - Water/Sewer	1,341.28	
5787	Utilities - Waste Management	1,019.85	
5788	Winter Carnival Expenses	1,019.05	
		730,562.76	730,562.76

Printed On: 06/27/2019



Commercial 72" Rectangular Folding Table

See More by [Lifetime](#)

CAD \$4,749.75

Product Overview

This Lifetime Commercial 72" Rectangular Folding Table is constructed of high-density polyethylene and have three adjustable height settings. They will not crack, chip or peel, and are built for indoor and outdoor use. The patented steel frame design provides a sturdy foundation and is protected with a powder-coated, weather-resistant finish. It is perfect for your home, office, outdoor activities and more.



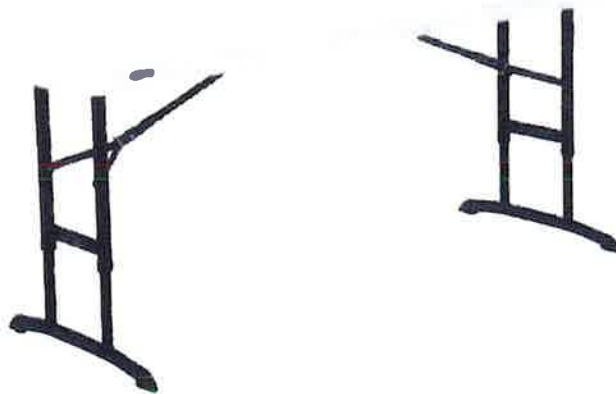

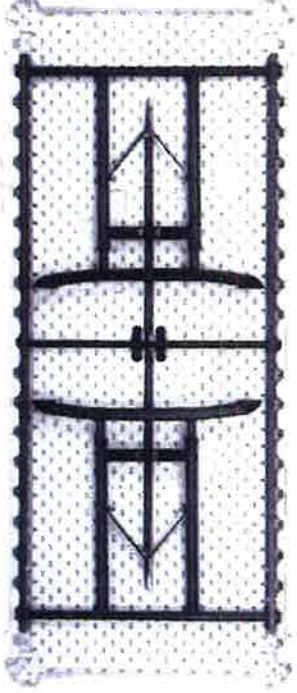

09/10/2019

To:
ELKS LODGE #45
Maureen
3103 - 30TH ST
VERNON, BC V1T 5E3
(250)549-1883



Project:
Elks Lodge - slicer

From:
Canadian Restaurant Supply Ltd
Kaz Zanitajs
6 - 2604 Enterprise Way
Kelowna, BC V1X 7Y5
250-979-1442
2509791442 211 (Contact)

Customer ID: 00286

Job Reference Number: 14341

Quote Valid for 15 days only

Item	Qty	Description	Sell	Sell Total
	1 ea	FOOD SLICER, ELECTRIC MVP Group Canada Model No. AX-S13G Axis Heavy Duty Slicer, manual, 13" carbon steel blade, gear driven, ring guard, dual action sharpening system, self-locking arm, slice thickness adjustment knob, up to 5/8" thick slices, noiseless operation, anodized aluminum construction, 0.50 HP, 120v/60/1-ph, cord, NEMA 5-15P, NSF, cETLus	\$4,837.48	\$4,837.48
	1 ea	1 year parts & 1 year labor "on site" warranty is standard		
			ITEM TOTAL:	\$4,837.48
	1 ea	MEAT SLICER Hobart Canada Model No. HS6-1 Heavy Duty Meat Slicer, manual, 13" CleanCut™ removable knife & tool, burnished finish, removable meat grip assembly, removable ring guard cover, single action top mounted sharpener with Borazon™ stones, cleaning kickstand, 1/2 hp motor, 5.4amps, 120v/60hz/1-ph, NSF cETLus	\$4,999.00	<Alternate>
	1 ea	WARRANTY-STANDARD Standard warranty - 1 Year limited warranty (contact Hobart FEG Canada for details)		<Alternate>
			ITEM TOTAL: <Alternate>	\$4,999.00
	1 ea	MUFFIN PAN Crown Brands Canada Model No. 6282 Packed 6 ea Johnson-Rose™ - Mushroom Top Muffin Pan, (12) muffin cups, 3-1/8 oz. per cup, 20-3/4" x 14-1/2" O.A., silicone coated heavy duty steel (NOT dishwasher safe)	\$57.99	\$57.99
			ITEM TOTAL:	\$57.99
			Merchandise	\$4,895.47
			Tax 7%	\$342.68
			Total	\$5,238.15

Initial: _____
Page 1 of 2

NOTES:

- 1) Pricing is in Canadian dollars, and includes exchange, brokerage, and duty where applicable.
- 2) Delivery to your location is not calculated on this quote. Please advise of quantity and destination.
- 3) For special order items, full payment or PO with approved CRS credit account is required at the time of ordering.
- 4) Credit cards-Visa or MasterCard are accepted
- 5) Manufacturers lead times are not guaranteed
- 6) Special order items cannot be canceled or returned once order is placed.
- **If ordering equipment, please check that the model's dimensions do not exceed your kitchen or building's door/passageway restrictions and that you have adequate and appropriate power source to accommodate the equipment you're purchasing****
- 7) Install available by CRS's Certified Service Department! Please contact your SalesRepresentative for more information.

**** IMPORTANT ****

We reserve the right to revise pricing due to USD exchange rate and manufacturer price list revisions. Special order items cannot be canceled or returned once order is placed.

Acceptance: _____ Date: _____

Printed Name: _____

Project Grand Total: \$5,238.15

AXIS



AX-S13G 13" Meat Slicer (Gear)



Dual Action Blade
Sharpening System

AXIS

AX-S13G - 13" GEAR MEAT SLICER

The Axis S-13G gear slicer is equipped with a .50 HP fan-cooled motor. The flow line design and rounded edges of the polished aluminum body makes your clean up an easy task. In addition to this, the high carbon steel (hard chromed) blade can slice large and heavy pieces of meat effortlessly. The carriage, blade cover and end-grip are removable for easy maintenance. Our precision dual action sharpening provides the operator with perfect grinding and trimming.

STANDARD FEATURES

- Self-locking arm
- High performance .50 HP motor
- Fixed ring guard
- Slice deflector for blade cleaning
- Noiseless operation
- Precision gear thickness adjustment
- Heavy duty application
- Ideal for slicing sausage, meat and cheese
- Carbon steel 13" blade
- No holes or crevices, provides for easy maintenance
- Gears secured in oil bath

13" GEAR MEAT SLICER

STANDARD FEATURES (cont.)

- Dual action blade sharpening system for precision cutting
- Gravity feed gear-driven slicer
- Reduction box technology allows for seamless performance
- 45° inclined blade
- Dual action sharpener
- Fixed ring guard
- ON/OFF one touch s/s switches with LED
- Removable parts for cleaning: blade cover, product-holder plate, aluminum meat grip, stainless steel slice deflector
- Blade with NARROW BAND of chromium-plated hardened steel
- Readily removable transparent Plexiglas Protection at product-holder plate



WARRANTY:

One year parts and labor on site

Model	Blade Size	Horsepower	Electrical	RPM	Ship Weight	Dimensions (W x D x H)
AX-S13G	13" / 330mm	.50HP	120V/60/1	300	99 Lbs	28.7" x 17.7" x 20.5"

MVP GROUP CORPORATION
 5659 Royalmount Ave. Montreal, QC Canada H4P 2P9
 Tel: 514-737-9701 888-275-4538 Fax: 514-342-3854
 www.mvpgroupcorp.com / sales@mvpgroupcorp.com

MVP
 GROUP

HOBART701 S Ridge Avenue, Troy, OH 45374
1-888-4HOBART • www.hobartcorp.com**HS6/HS6N
SLICER****HOBART****STANDARD FEATURES****KNIFE**

- 13" CleanCut™ Knife
- Removable Ring Guard Cover
- Zero Knife Exposure
- Heavy-Gauge Stainless Steel Knife Cover
- Top-Mounted Borazon Stone Sharpener

OPERATION

- ½ H.P. Knife Drive Motor

INTERLOCKS

- No-Volt Release

HOUSING AND BASE

- Burnished Aluminum Base
- Machined Grooves on Gauge Plate and Knife Cover
- Exclusive Tilting, Removable Carriage System
- Electroless Nickel Plated Single Slide Rod with Reservoir Wick in Transport
- Double-Action Indexing Cam
- Spring Kickstand
- Ergonomic-Style Handle
- Rear-Mounted, Removable Meat/Vegetable Grip Arm

MODELS

- HS6 – Manual Slicer/Burnished Finish with Removable Knife Feature
- HS6N – Manual Slicer/Burnished Finish with Non-Removable Knife Feature

ACCESSORIES

- Full Fence
- Food Chute
- Debris Deflector

Specifications, Details and Dimensions on Inside and Back.

**HS6/HS6N SLICER**

HS6/HS6N SLICER



701 S Ridge Avenue, Troy, OH 45374
1-888-4HOBART • www.hobartcorp.com

SOLUTIONS / BENEFITS

PRECISION SLICING

13" CleanCut™ Knife

- Super alloy edge stays sharp longer
- Lasts two to three times longer than carbon coated or stainless steel knives

Top Mounted Borazon Stone Sharpener

- Single-action sharpens and hones in just 15 seconds
- Removable and warewasher safe for easy cleaning and sanitation – can be used wet or dry
- Lifetime guaranteed Borazon sharpening stones provide maximum performance with reduced maintenance costs

Machined Grooves on Gauge Plate and Knife Cover

- Reduces drag for smoother slicing motion

Double-Action Indexing Cam

- The first full revolution of the indexing knob provides precise control of shaving, chipping and thin slicing
- The second revolution opens the gauge plate quickly for thicker slicing
- Gauge plate holds position for consistent, precision slicing

EASY TO USE

½ H.P. Knife Drive Motor

- Reserve power runs at 430 rpm for optimum results

Electroless Nickel Plated Single Slide Rod with Reservoir Wick in Transport

- Smooth operation with continuous lubrication of carriage rod

Zero Knife Exposure*

- Knife edge is covered when sharpener is both mounted and removed making cleaning easier
- Gauge plate remains closed during operation of sharpener

No Volt Release

- Slicer must be restarted if power fails or slicer is unplugged

EASY TO CLEAN

Removable Knife Option* – HS6

- Knife easily removes with patented removal tool
- Area within ring guard is open for faster cleaning
- Knife and tool are warewasher safe for easy cleaning and sanitation

Removable Ring Guard Cover*

- Catches product debris around the knife for easy removal during cleaning
- Reduces time to 'floss' during cleaning

Exclusive Tilting, Removable Carriage System*

- Tilt design allows for ease of mid-day cleaning
- Removable for complete cleaning and sanitation

Rear-Mounted, Removable Meat Grip Arm

- Opens up front of product tray for unobstructed loading
- Removable meat grip allows for easy cleaning

Spring Kickstand

- Props machine for easy cleaning underneath slicer

Sanitary Burnished Aluminum Base

- Limited cracks/crevices or bolt holes where product can lodge and bacteria may grow
- Easy clean up and durable finish

*Feature unique to Hobart

HOBART701 S Ridge Avenue, Troy, OH 45374
1-888-4HOBART • www.hobartcorp.com**HS6/HS6N
SLICER**

SPECIFICATIONS

KNIFE

13" CleanCut Knife: The knife is approximately 13 inches, constructed of 304L stainless steel and high performance Stellite alloy. Knife cover is retained magnetically, and is quickly removed by pulling straight back on the top cover knob.

Removable Knife Option HS6: The patented knife removal tool covers the knife edge and safely removes knife from gauge plate to allow for thorough cleaning.

Removable Ring Guard Cover: Fits on top of ring guard to catch food debris. When removed, reveals a 0.12" space between knife and guard for easier flossing. Ring guard is made with Zytel™ plastic and can be washed in warewasher or three compartment sink.

Zero Knife Exposure: Knife edge is not exposed during cleaning or sharpening procedures.

Top Mounted Borazon Stone Sharpener: Single action operation utilizing two Borazon stones to sharpen and hone in five seconds. Removable, top mounted and warewasher safe. When sharpener is removed for cleaning, knife edge is completely shielded. Borazon stones have a lifetime guarantee.

MOTOR

Poly V-Belt Knife Drive System: Knife is driven by a Hobart Poly V belt and runs at 430 rpm for optimal performance.

½ H.P. Knife Drive Motor: ½ H.P. permanently lubricated ball bearings. Single phase capacitor-start, induction run.

INTERLOCKS

No Volt Release: In the event of a power loss, slicer must be restarted before operation can continue.

HOUSING AND BASE

Sanitary Burnished Aluminum Base: One-piece base has fewer places to harbor soil and is easier to clean. Limits holes or crevices in which food can lodge.

Finish: Stainless steel top cover, anodized aluminum product tray and gauge plate.

Exclusive Tilting, Removable Carriage System: Aluminum product tray tilts easily for mid-day cleaning and is removable for thorough cleaning and sanitation procedures. The carriage has 12.5" manual travel.

Electroless Nickel Plated Single Slide Rod with Reservoir Wick in Transport: Transport slide rod is E-Nickel electroless plated. Slide rod bearings feature an oil reservoir/oil wick.

Double-Action Indexing Cam: A solid construction index knob moves the gauge plate via a barrel cam ensuring consistent slice thickness across machine and over time. First revolution of index cam for precision slicing; second revolution for thicker slicing selection.

Spring Kickstand: Helps hold slicer in tilted position for cleaning beneath the machine.

Ergonomic Style Handle: Specially shaped and positioned for ease of use during manual operation.

Rear Mounted, Removable Meat Grip Arm: Rear mounted grip is high strength thermoplastic. Swings out of way when not in use.

Electrical Specification: 120/60/1; 5.4 Amps.

Switch: Moisture protected push button switch.

Cord & Plug: 6-foot, three-wire power supply cord and plug. Plug not furnished on export models.

Capacity: The carriage will take food up to 5¾" x 10¾" rectangle or 7.5" in diameter.

Gauge Plate: Gauge plate is a heavy aluminum extrusion with machined grooves for smooth feeding. Adjustable to cut any thickness of slice up to 1".

Warranty: All parts and service coverage for one year including knife. Lifetime guarantee on Borazon stones in the sharpening system.

Shipping Weight: 128 lbs.

HS6/HS6N SLICER



701 S Ridge Avenue, Troy, OH 45374
1-888-4HOBART • www.hobartcorp.com

DETAILS AND DIMENSIONS

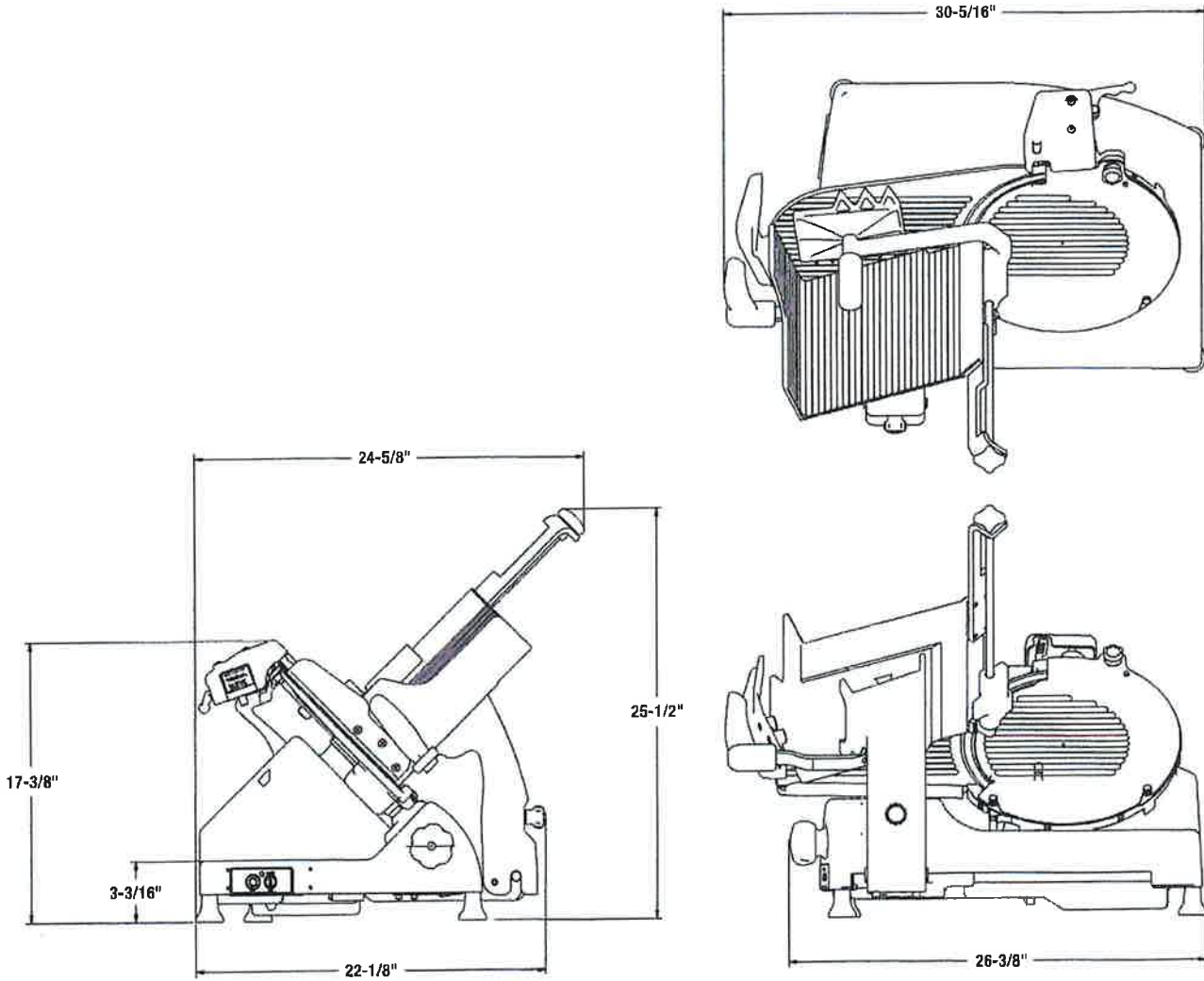

As continued product improvement is a policy of Hobart, specifications are subject to change without notice.



Scouts Canada 1st BX Scouts, Vernon, BC

1stBX.com

Shawna Bader (Fundraising Coordinator)
Dave Burge (Group Treasurer)

June 30, 2019

Regarding: Elks Lodge No. 45 (Vernon)

Request for Funding from: North Okanagan Regional District

To Whom It May Concern;

I am writing this letter to show support for the Vernon Elks Lodge #45's application to BC Gaming Community Grant for the Community Donation and the Vernon RibFest 2020.

The 1st BX Scout Group depends on community contributions to provide both boys and girls, aged 5-17, a learn by doing program teaching leadership, outdoor skills, community service, etc. with the stated aim "to help develop well rounded youth, better prepared for success in the world." We have approximately 45 youth in our group and 18 adults volunteering to support our group in leadership positions.

The Elks #45 support has helped youth in the following ways:

- Camp costs
- Camp equipment (stove, tents, lanterns, etc.)
- Meeting facilities
- Training and meeting resources (binders, paper, ropes, knives, etc.)

The Elks No. 45 has provided our organization with an annual financial donation for many years now. We often volunteer washing dishes for the Elks when they have their dinners. The Elks are a great support to us and we value our relationship with the Elks Lodge. We are in full support of the Elks Lodge application for Vernon RibFest 2020, which in turn will benefit community members and groups in our community.

I am pleased to provide a letter of support for the Elks Lodge No. 45 Vernon. If you have questions, please contact me.

Sincerely,

Scouter Shawna Bader
1st BX Scouts Group Fundraising Coordinator
Vernon, BC

Dave Burge
1st BX Scouts Group Treasurer

North Okanagan Regional District

Funding Request

Elks Lodge No. 45 – Vernon

I am pleased to write this Letter of Support for the Elks Lodge No. 45's application for funding seed money for the 2nd ***Annual Vernon RibFest*** to be held July 3-5, 2020. Over the past number of years, the Elks have supported the work of the ***Santas Anonymous Society*** through an annual financial donation. The ***Society*** uses these funds to purchase new toys and to help keep our doors open year round.

The Society's Mission

The Mission of the ***Santas Anonymous Society*** is to collect and distribute new and "gently used" toys, clothing or other items for the benefit of underprivileged children, up to the age of twelve, in the Greater Vernon and North Okanagan area. The ***Society*** provides a community resource for parents/guardians who find themselves financially challenged and in need of help to acquire Christmas and birthday gifts for their children. The ***Society's*** policy of providing each child with a new and some refurbished gifts requires a continuous input of resources from the community.

Community Support/Coordination

Santas Anonymous relies upon the support from individuals, businesses, and non-profit organizations such as the **Elks Lodge No. 45** (Vernon). Many Vernon area community members also provide support by donating used toys that the volunteer staff, consisting of some twelve individuals, refurbish and distribute. Also some of our volunteers attend Elk's Lodge functions, as well as assisting with some of their events.

This past year the ***Society*** assisted some 400 children and their families. The costs incurred in purchasing a good selection of new gifts that appeal to both younger and older children are substantial. Overall, the ***Society*** donates approximately 2,000 items annually, with some 50% being new items.

Sincerely,
Patricia Hosking, Board Member

Perry Wainwright, President

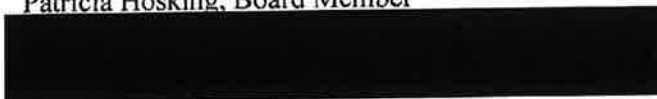

Vernon BMX Association



Contact: Shylo Orchard, Vernon BMX Club President/Track Operator

E-mail:

Phone:



The Vernon BMX Association has been a part of this wonderful community of ours since 1982. The Club has over 280 members and right now range from ages 2 years old to 73 years young. The Club runs from April to October and we host practises/races every Monday and Tuesday.

We have always been a successful organization and I credit the amazing back up we get from City of Vernon and all who are part of the community.

The Elks Hall has given us many opportunities over the years to help fund our non-profit group. We try extremely hard to keep our fees low for our members. We are one of the few Clubs left in Canada that charge \$5 a race. Some clubs fees are \$12-\$14 every race and they need to pay for practises as well. Our practises are for all our members and we have at leave 4 amazing Coaches on the track teaching our members skills during these practises. We even break our practises up into groups for maximum safety and learning opportunities for every skill level and rider. We are able to keep our practises FREE because the continued support from the Vernon Elks Hall. Other Clubs will offer skill clinics for money. From about \$85 to \$175 a day. We are so lucky to have this kind of support! And Thankful!!

We've had scheduled fundraising times over the course of a year to raise money at the Elks hall. We appreciate the fact that the Elks will even give us a call randomly and ask if we would be interested in fundraising at a certain upcoming event. Giving us extra opportunities to make money, so in turn, we can continue to give back to our members and BMX Families!

When the Elks Hall Hosted the first Annual RibFest, we were asked if we wanted to host a 50/50 for one day for funds and include a Vernon BMX Club information table to reach out to more families and riders to show them the amazing opportunities to “bicycle racing” and the beautiful city park that is still a hidden gem in our community. We raised \$985 that one day for our Club. We could not be where we are today without the Elks support and continually looking for way to help us.

We hope the Elks get another opportunity and the support to continue with the RibFest. I saw a ton of community members I know personally that 9 hours I was there and heard of lots of other people that look forward to next year being their first year! Already the event has grown!

The Vernon BMX Club will definitely be interested in anyway helping out and volunteering at this incredible community event!!

Kind Regards,

Shylo Orchard, Vernon BMX Club President/Track Operator

VERNON TREATMENT CENTRE
(Operated by The Shuswap Okanagan Treatment Centre Society)

#3. 2810 – 48th Ave.
Vernon, BC V1T 3R4
Telephone: 250-542-6151
email: vernontreatment@telus.net

September 25, 2019

To Whom it May Concern:

Re: Vernon Elks Lodge #45/RibFest

Our organization offers a two week intensive Out Patient Program for people with addiction issues. The course is open to people of all ages. We also serve as a resource centre and referral service for people with addiction issues and their families.

Our facilities are also used for numerous Twelve Step Recovery Meetings. Sixty to eighty people take our course each year and many go on to a life of sobriety.

We have received annual grants of \$2,000.00 from the Elks Lodge for a number of years and this year were privileged to have a booth at RibFest 2019, which was tremendously successful. It gave us a valuable opportunity to promote our services and create public awareness of our program. It also assisted us in fund raising through the sale of raffle and 50/50 tickets.

Our organization fully supports the Vernon Elks Lodge #45 in their operation of RibFest. It provides a tremendous Community gathering and benefits many in the area.

Yours truly

Robert B. Shuler, CPA, CA



Treasurer
Telephone: 250-5451778
email: rbshulerca@telus.net

September 29, 2019



Zirka Ukrainian Dancers of the Okanagan Valley
P.O. Box 23017
RPO West End
Vernon, B.C.
V1T9L8
zirka.ukrainian.dancers@gmail.com

I am writing this letter, on behalf of the Zirka Ukrainian Dancers of the Okanagan Valley, to show support for the Vernon Elks Lodge #45 regarding their application to City of Vernon Grant.

Zirka Ukrainian Dancers of the Okanagan Valley is a non-profit organization who provides Ukrainian dance in after school programs for youth ages 7-17. We are a small group consisting of 11 dancers who showcase our talents and Ukrainian culture throughout the year at various venues, i.e. in the senior facilities in Vernon and Kelowna to name a few.

Because we are non-profit, we depend on various organizations like the Elks Hall to help offset the costs of costuming and travel to events where we perform. Our costumes are 5-6 piece elaborate hand-made pieces that are sewn in the Ukraine and which, if we did not have community support, we could not afford to purchase.

We depend greatly on the generosity and support of the Elks Hall and, in turn, this helps us to keep our dance fees for our families low and affordable.

Our organization has been directly involved with the Elks Hall for the past 4 years. They have been instrumental in our group holding our year end dance and dinner at their Hall. The ladies of the Elk Hall have solely cooked our year end Ukrainian dinners and made our event a huge success. They were more than generous to our dancers in gifting them a most sizeable donation which helped us to provide new costumes for the upcoming year. We could not hold this event without their generosity.

The Elks Hall is a wonderful, committed, selfless, organization of people that volunteer many, many hours of their time, meal preparation, etc., so they can host community suppers throughout the year which are affordable for all. Everyone in our community would miss them sorely if they were not here doing the work they do.

We are also on their list to provide "dish duty" to other events they host in their hall. For three hours of work cleaning dishes and helping out, we are given an opportunity to give back. We feel very blessed to help out throughout the year when we are needed. It is our way of giving back to the Elks for their support of our dancers. So yes, we support them in their quest for funding, they are a very worthwhile organization within our community.

Yours truly,

Wendy Mason
Treasurer
Board of Directors



The Corporation of the City of Vernon

COUNCIL DISCRETIONARY GRANT APPLICATION FORM

IMPORTANT: The deadline for Council Discretionary Grant Applications are semi-annual being April 30 and October 31 each calendar year.

Applications will only be accepted during the intake periods of April 1 - April 30 and October 1 to October 31. Applications must be submitted to the Director of Financial Services no later than 4:00pm on the application deadline (April 30th and October 31st), if City Hall is closed that day, on the next working day that City Hall is open.

Applicants may run the risk of grant funding being depleted if waiting to apply until the October intake deadline.

If grant applications are received after the cut off periods they will be returned to the applicant and must be submitted at the next intake period.

Please note: Incomplete applications will not be considered

ORGANIZATION INFORMATION

NAME OF ORGANIZATION APPLYING FOR COUNCIL DISCRETIONARY GRANT:	Independent Living Vernon Society
CONTACT PERSON:	Laura Hockman
ORGANIZATION MAILING ADDRESS:	#107, 3402-27th Ave, Vernon, BC V1T 1S1
BUSINESS PHONE:	250-545-9292
EMAIL ADDRESS:	laura@ilvernon.ca
REGISTERED NON PROFIT SOCIETY INCORPORATION NUMBER (required):	S00 31012

"Personal information contained on this form is collected under the Freedom of Information and Protection of Privacy Act and will be used only for the purposes of responding to your request".

City Hall Address: 3400 30th Street, Vernon BC, V1T 5E6
Inquiries: 250-545-1361
Web: www.vernon.ca



The Corporation of the City of Vernon

COUNCIL DISCRETIONARY GRANT APPLICATION FORM

ORGANIZATION GOALS, OBJECTIVES AND ACTIVITIES:

Independent Living Vernon (ILV) is a resource centre for people with a variety of disabilities. ILV's mission is to create sustainable community links, to work for societal change, and to remove barriers so that people with disabilities have the opportunity to realize their full potential. We fulfill our mission by following the principles of the international Independent Living Movement: Consumer Control, Peer Support, Community based, and Non Profit. IL Centres are run by and for people with a variety of disabilities, meaning that a minimum of 51% of all IL Centre Board members and staff must identify as having a disability. Having this requirement in the Bylaws of the four partnering organizations, means that people with lived experience of disability are directly involved in the design, implementation, and evaluation of the proposed project.

SERVICE PROVIDED TO THE COMMUNITY:

ILV offers a range of programs and services to people with a variety of disabilities. ILV offers two peer support groups, one for adults and the other for Youth with disabilities, between the ages of 16-29 yrs. ILV is fortunate to have three Registered Social Workers on staff, who provide one on one advocacy with people with disabilities. Examples of advocacy includes assisting people to access Provincial and Federal Disability Income security programs, referrals to community and government programs.

Information and Referral is ILVs busiest program. People with disabilities need information on community and government programs and often require hard copies of applications and posters for services, as they do not have access to a computer at home. In addition, other than the library, ILV also offers two computers for internet access and word processing for anyone in the community to access. ILV coordinates the Volunteer Income Tax Program, which sees trained volunteers complete over 2000 tax returns for people with low incomes.

ILV makes over 20,000 contacts with clients in person, by telephone, and online (Social Media & email) each year.

A PROFILE AND HISTORY OF THE ORGANIZATION AND ITS ACCOMPLISHMENTS:

ILV became a Registered Charity on September 13, 1993. Since then ILV has offered unique programs and services to people with a variety of disabilities. ILV is part of network of 25 Independent Living (IL) Centres in Canada and over a 1000 IL centres worldwide. Having this connection to a worldwide network of IL centres, provides an opportunity to ILV to remain up to date about issues facing people with disabilities and best practices emerging. One of the core strengths of ILV is its ability to build partnerships with various organizations. For example, ILV was instrumental in providing support to two non profit groups John Rudy Health Resource Centre and the FASD Okanagan Valley Assessment and Support Society. ILV offers in-kind supports such as office space, shared reception, phone/internet and use of office equipment, while the groups builds a foundation of funding for programs and services. Further, ILV is strongly involved in a local Community Action Team to address the local impact of the Overdose Provincial Emergency. ILV was recently successful in a highly competitive proposal process with the Community Action Initiative, 3 year Community Counselling Grants funding. Further, ILV was successful in receiving funding to offer two consultation sessions about the development of Provincial Accessibility Legislation in the North Okanagan and for Indigenous People with disabilities living on reserve.

PLEASE IDENTIFY THE STEPS YOUR ORGANIZATION HAS TAKEN TO ACQUIRE GRANTS FROM OTHER SOURCES:

ILV has been able to secure funding to purchase the other required accessible equipment (Monitors, Monitor mounts, accessible keyboards and desks and ergonomic chairs) to make 2 accessible workstations for two key ILV staff.

Currently ILV has grants pending to secure funding to run the programs and services for people with disabilities. For example we have an application pending with the Disability Alliance of BC for funding to increase accessibility for people with disabilities in the Vernon area. ILV also submitted an application to the federal government for the three year proposed program to increase the financial security of persons with disabilities.



The Corporation of the City of Vernon

COUNCIL DISCRETIONARY GRANT APPLICATION FORM

GRANT REQUEST

(You may wish to provide attachments, please note below where these items can be found.)

<p>AMOUNT OF REQUEST: Total request: \$4,458.00 2 - Microsoft Surface Laptops - \$3,460.00 2 - Microsoft Docking Station - \$520.00 Taxes - \$478.00</p>
<p>IN-KIND SERVICES: (please describe and include cost) ILV will pay for the \$500.00 in IT services to set up the laptops.</p> <p>ILV already has the 2 Computer Monitors, 1 monitor mount, 2 accessible keyboards, 2 accessible desks, and 2 ergonomic chairs for the staff workstations valued at \$3,000.00</p>
<p>PURPOSE OF GRANT AND PROPOSED ALLOCATION OF FUNDS: The purpose of the funds is to purchase two laptops and docking stations ILV staff. These laptops will assist our staff to have a accessible and reliable computer workstation, when they are working with consumers one on one. At the same time, the laptops will provide the portability needed when staff are running programs or need to move offices to better accommodate the needs of consumers. For example, when consumers come in the office with a large scooter or power wheelchair, it is more accessible to meet with them in our classroom space, with a laptop, they will be able to easily move the laptop to the classroom with them.</p>
<p>BENEFITS TO COMMUNITY RESULTING FROM GRANT OR CITY GOALS AND OBJECTIVES THAT WILL BE MET, IF THE GRANT IS APPROVED: The two main benefits to the community resulting from this grant are assisting an organization to provide accessible one on one support options to accommodate people with various disabilities and to ensure ILV staff have the needed technology to offer accessible programs to people with disabilities in the community.</p>
<p>DEGREE OF COMMUNITY FINANCIAL SUPPORT OR SPONSORSHIP: ILV is fortunate to have a financial support and sponsorship from various small businesses and individuals in the community. Last year we received \$17,323 in donations from the community. That was one of our best years of donations.</p> <p>In addition to our Core funding, Gaming grant, Fee for service and fundraising dollars, ILV is fortunate to many local sponsorship from local business and individuals in the community. On average we have about 25 sponsors per event or fundraiser we host. Sponsors provide time, goods for silent auction or door prizes, and expertise for planning events.</p> <p>ILV is fortunate to also have volunteers who provide 1200 volunteer hours to the programs and services ILV offers to the community.</p>

City Hall Address: 3400 30th Street, Vernon BC, V1T 5E6

Inquiries: 250-545-1361

Web: www.vernon.ca



The Corporation of the City of Vernon COUNCIL DISCRETIONARY GRANT APPLICATION FORM

DEGREE OF DEMONSTRATED ECONOMIC DEVELOPMENT, ENVIRONMENTAL STEWARDSHIP OR SOCIAL BENEFIT THAT MAY BE GENERATED BY THE AWARD OF A COUNCIL DISCRETIONARY GRANT:

By approving this grant, the social benefit for the community will increase by providing funding to increase the availability of accessible program options for people with a variety of disabilities in the community.

GRANT QUALIFICATION CHECKLIST (please check all that apply):

- Community Based
- Providing a service which is not provided by any other group or organization within the City or which is provided for in another municipality and used by residents
- Must only submit one application per calendar year
- Grant request is not to cover retroactive funding or to cover a deficit

Note: Organizations do not qualify for the discretionary grant program if they are in receipt of regional funding or are receiving grants or other assistance from the City of Vernon.

GRANT REQUIREMENTS (please attach to your grant application):

- Most Recent Set of Financial Statements
- Minutes of Most Recent Annual General Meeting
- List of Members of the Executive (including positions held, address and contact numbers)

In the case of newly formed groups, a budget and information regarding the organization purpose including list of Board of Directors will be sufficient.

October 30, 2019

Date

Signature



Microsoft

Microsoft Surface Laptop 2 LQP-00001 13.5" Touch Screen Notebook, 1.7 GHz Core i5 8350U, 256 GB SSD, 8 GB LPDDR3, Windows 10 Pro

(0) [Write a review](#) [Ask a question](#)

[View Product Details](#)



24377208-en-microsoft-surface-laptop-2-lqp-00001-135-touch-screen-notebook-17-ghz-core-i5-8350u-256-gb-ssd-8-gb-lpddr3-windows-10-pro

\$1,729.99



Product Details

The perfect partner for productivity, new Surface Laptop 2 for Business has more multitasking power to get more done with the latest quad-core powered 8th Gen Intel Core processor. All-day battery life and amazing sound keep you moving. See your work in true-to-life color with the vibrant and durable 13.5" PixelSense Display.

- 13.5-inch WLED Touch Screen display with 2256 x 1504 screen resolution
- 1.7 GHz Intel Core i5 8350U processor (6 MB cache)
- 8 GB LPDDR3 SDRAM system memory
- 256 GB Solid State Drive storage
- Windows 10 Professional operating system pre-installed
- Intel UHD 620 graphics
- WiFi, Bluetooth connectivity
- Ports: 1 x USB 3.0, Mini DisplayPort, 3.5mm headphone, Surface Connect port
- battery with Up to 14.5 hours runtime
- Dimensions: 0.6"H x 12.1"W x 8.8"D, 2.8 lbs
- 1-Year warranty

Specifications

Processor Cache	6 MB	Number of USB 3.0 Ports	1
Weight (lb)	2.8 lbs	Battery Runtime	Up to 14.5 Hours
Webcam	Yes	Wireless (Wi-Fi)	Yes
Warranty	1-year	Speaker Details	Omnisonic Speakers with Dolby Audio Premium
Condition	New	Backlit Keyboard	No
Dimensions (inches)	0.6"H x 12.1"W x 8.8"D		

24377208-en-microsoft-surface-laptop-2-lqp-00001-135-touch-screen-notebook-17-ghz-core-i5-8350u-256-gb-ssd-8-gb-lpddr3-windows-10-pro

\$1,729.99





Microsoft

Microsoft Surface Docking Station (PF3-00005)

(0) Write a review Ask a question

[View Product Details](#)



2259750-en-microsoft-surface-docking-station-pf3-00005

\$259.99

ADD TO CART

Product Details

Surface Dock instantly transforms your ultraportable Surface into a desktop PC. Simply plug in the SurfaceConnect cable to charge your device and access external monitors, a keyboard, mouse, and more.

- Dock Station
- Dimensions: 1.2"H x 5.1"W x 2.4"D
- Compatibility: Surface Book, Surface Laptop, Surface Pro, Surface Pro 3, Surface Pro 4
- Connector: 3.5mm audio, Mini DisplayPort, RJ-45, USB 3.0
- Connector Type: Audio line-out, Mini DisplayPort, Network, USB 3.0
- Networking Protocol: Ethernet, Fast Ethernet, Gigabit Ethernet
- 1-Year Warranty

Specifications

Weight (lb)	1.2 lbs	Ethernet Ports	RJ-45 LAN
Condition	New	Height (inches)	1.2
Display Ports	0 0 2	Number of USB 3.0 Ports	4
Power Source	Plug-In	Number of VGA Ports	0
Depth (inches)	2.4	Auxiliary Input (3.5mm)	Yes
Width (inches)	5.1	Laptop Compatibility	Surface Book, Surface Laptop, Surface Pro, Surface Pro 3, Surface Pro 4
Colour Family	Black	Operating System Requirements	Works with Surface Book, Book 2, Pro 3, Pro 4, Pro 6, Pro and



2259750-en-microsoft-surface-docking-station-pf3-00005

\$259.99

ADD TO CART

INDEPENDENT LIVING VERNON SOCIETY

(Unaudited - See Notice to Reader)

FINANCIAL STATEMENTS

March 31, 2018

INDEPENDENT LIVING VERNON SOCIETY
March 31, 2018

CONTENTS	Page
NOTICE TO READER	3
FINANCIAL STATEMENTS	
Statement of Financial Position	4
Statement of Changes in Net Assets	5
Statement of Operations	6
Statement of Cash Flows	7
Summary of Significant Accounting Policies	8
Notes to the Financial Statements	9



ROSSWORN HENDERSON LLP *Chartered Professional Accountants*

C.L. Henderson, BBA, CPA, CA, Partner*
D.W. Stadnyk, CPA, CA, Partner*
N.R. Merrill, CPA, CMA, Partner*

* providing professional services through a corporation



NOTICE TO READER

On the basis of information provided by the Society, we have compiled the statement of financial position of Independent Living Vernon Society as at March 31, 2018 and the statements of operations, changes in net assets and cash flows for the year then ended.

We have not performed an audit or a review engagement in respect of these financial statements and, accordingly, we express no assurance thereon.

The financial statements were prepared on a basis consistent with the basis on which the financial statements that related to the preceding period were prepared.

Readers are cautioned that these statements may not be appropriate for their purposes.

Enderby, BC
September 9, 2018

Chartered Professional Accountants

Rossworn Henderson LLP is a Limited Liability Partnership registered in British Columbia

INDEPENDENT LIVING VERNON SOCIETY

Statement of Financial Position
(Unaudited - See Notice to Reader)

As at March 31, 2018

	2018	2017
Assets		
Current		
Cash (Note 2)	\$ 65,057	\$ 63,108
Accounts receivable (Note 3)	1,035	9,003
Prepaid expenses	2,584	970
	<u>68,676</u>	<u>73,081</u>
Tangible capital assets (Note 4)	3,943	1,521
	<u>\$ 72,619</u>	<u>\$ 74,602</u>
Liabilities		
Current		
Accounts payable and accrued liabilities	\$ 19,921	\$ 24,344
	<u>19,921</u>	<u>24,344</u>
Net assets		
Invested in tangible capital assets	3,943	1,521
Internally restricted	10,490	10,294
Externally restricted	31,188	30,461
Unrestricted	7,077	7,982
	<u>52,698</u>	<u>50,258</u>
	<u>\$ 72,619</u>	<u>\$ 74,602</u>

Approved on behalf of the Board:

Director _____

Director _____

INDEPENDENT LIVING VERNON SOCIETY

Statement of Changes in Net Assets
(Unaudited - See Notice to Reader)

As at March 31, 2018

	Unrestricted	Invested in tangible capital assets	Internally restricted	Externally restricted	2018	2017
Net assets, opening	\$ 7,983	\$ 1,521	\$ 10,294	\$ 30,461	\$ 50,259	\$ 23,189
Excess (deficiency) of revenue over expenses	2,914	(1,397)	196	727	2,440	27,069
	10,897	124	10,490	31,188	52,699	50,258
Transfers						
Tangible capital assets acquired	(3,819)	3,819				
	\$ 7,078	\$ 3,943	\$ 10,490	\$ 31,188	\$ 52,699	\$ 50,258

INDEPENDENT LIVING VERNON SOCIETY

Statement of Operations

(Unaudited - See Notice to Reader)

For the year ended March 31, 2018

	2018	2017
Revenue		
Grants	\$ 80,931	\$ 108,064
Sales of Service	78,787	73,983
Gaming	25,000	25,000
Donations	17,323	7,177
Fundraising	5,419	5,913
Rent	955	
Other revenue	1,591	2,038
	<u>210,006</u>	<u>222,175</u>
Expenses		
Advertising and promotion	183	566
Bank charges and interest	3,012	2,850
Employee development		225
Equipment rent	3,699	3,698
Fundraising	3,480	2,450
Insurance	3,727	4,508
Memberships and dues	770	978
Office	16,566	7,325
Professional fees	5,353	2,584
Program expenses	10,945	8,683
Rent	17,829	19,061
Repairs and maintenance	7,394	6,910
Telephone & communications	7,206	7,172
Travel	3,653	1,802
Wages and benefits	122,352	125,533
	<u>206,169</u>	<u>194,345</u>
Excess of revenue over expenses before the following:	3,837	27,830
Amortization of tangible capital assets	(1,397)	(761)
Excess of revenue over expenses	<u>\$ 2,440</u>	<u>\$ 27,069</u>

INDEPENDENT LIVING VERNON SOCIETY**Statement of Cash Flows**

(Unaudited - See Notice to Reader)

For the year ended March 31, 2018

	2018	2017
Sources of cash		
Cash from operating activities	\$ 217,776	\$ 215,500
Interest receipts	196	51
	<u>217,972</u>	<u>215,551</u>
Uses of cash		
Payments to suppliers and employees	<u>(212,206)</u>	<u>(180,249)</u>
Total cash flows from operating activities	5,766	35,302
Investing activities		
Tangible capital assets acquired	(3,818)	(2,282)
Increase in cash	1,948	33,020
Cash, beginning of year	<u>63,109</u>	<u>30,088</u>
Cash, end of year	<u>\$ 65,057</u>	<u>\$ 63,108</u>
Cash consist of:	2018	2017
Cash	\$ 29,210	\$ 27,274
Restricted cash	25,357	25,541
Temporary investments	10,490	10,294
	<u>\$ 65,057</u>	<u>\$ 63,109</u>

INDEPENDENT LIVING VERNON SOCIETY

Summary of Significant Accounting Policies

(Unaudited - See Notice to Reader)

For the year ended March 31, 2018

Purpose of the Society

The Independent Living Vernon Society (the "Society") is incorporated under the laws of the *Society Act* of British Columbia as a not-for-profit organization and is a registered charity under the *Income Tax Act (Canada)*. The Society provides education, peer counselling, referrals and support for persons with disabilities.

1. Significant Accounting Policies

a) Revenue recognition

The Society follows the deferral method of accounting for contributions.

Unrestricted contributions are recognized as revenue when received or receivable if the amount to be received can be reasonably estimated and collections is reasonably assured.

Externally restricted contributions other than gaming revenue are recognized as revenue in the year in which the related expenses are recognized. Contributions restricted for the purchase of capital assets are deferred and amortized into revenue at a rate corresponding with the amortization rate for the related capital assets.

Restricted investment income is recognized as revenue in the year in which the related expenses are recognized. Unrestricted investment income is recognized as revenue when earned.

Revenue from fees, contracts and sales of publications is recognized when the services are provided or the goods are sold.

All other contributions are recognized as revenue in the year in which the related expenses are recognized.

Contributed services:

A substantial number of volunteers contribute a significant amount of their time each year. Because of the difficulty of determining the fair value, contributed services are not recognized in the financial statements.

Pledges:

Pledges are not included in revenues until the funds are received.

Contributions from Independent Living Canada

The Society is funded primarily by the Independent Living Canada. Operating grants are recorded as revenue in the period to which they relate. Grants approved but not received at the end of the accounting period are accrued. When a portion of the grant relates to a future period, it is deferred and recognized in the subsequent period.

b) Tangible capital assets

Purchased tangible capital assets are recorded at cost. Contributed tangible capital assets are recorded at fair value at date of contribution. Constructed assets are recorded at cost when they become available for use. Volunteer labour used to construct assets is not capitalized due to difficulties in quantifying the benefit received. Assets are amortized over their estimated useful lives. Amortization is recognized in the Capital Fund. Management has estimated the useful lives to be:

Furniture and fixtures	5 years	Straight line
Computer equipment	3 years	Straight line

INDEPENDENT LIVING VERNON SOCIETY**Notes to the Financial Statements**

(Unaudited - See Notice to Reader)

For the year ended March 31, 2018

2. Cash

	<u>2018</u>	<u>2017</u>
Unrestricted cash	\$ 29,210	\$ 27,274
Restricted cash - gaming	25,357	25,541
Temporary investments	10,490	10,294
	<u>\$ 65,057</u>	<u>\$ 63,109</u>

3. Accounts receivable

	<u>2018</u>	<u>2017</u>
Trade accounts receivable	\$ 909	\$ 8,350
GST/HST receivable	126	652
	<u>\$ 1,035</u>	<u>\$ 9,002</u>

4. Tangible capital assets

	<u>Cost</u>	<u>Accumulated amortization</u>	<u>2018</u>	<u>2017</u>
Furniture and fixtures	\$ 2,011	\$ 335	\$ 1,676	\$
Computer equipment	4,090	1,823	2,267	1,521
	<u>\$ 6,101</u>	<u>\$ 2,158</u>	<u>\$ 3,943</u>	<u>\$ 1,521</u>

Independent Living Vernon Annual General Meeting Minutes

December 20, 2018

Present: Crystal, Arpen, Kelly, Lyla, Linda Patterson, Susan, Jess, Dean, Louise, Lisa, Suzie, Leon, Linda Godal, James Froese, Samantha Symons, and Allan Clarke.

Meeting called to order at 12:05pm.

Agenda: Motion to approve the agenda was made by Suzie S and seconded by Linda Patterson. All in favor.

Administration Report: Motion made to accept the Administration report moved by Lisa Brigs and seconded by Samantha. All in favor.

Financial Statements: Motion to approve financial statements made by Dean and seconded by Jess. All in favor.

Elections:

Louise Cain: Motion made by Crystal to elect Louise to the Board of Directors for a two year term. Seconded by Suzie S. All in favor.

Leon Schwartz: Motion made by Louise to elect Leon to the Board of Directors for a two year term. Seconded by Linda Godal. All in favor.

Linda Godal: Motion made by Suzie to elect Linda Godal to the Board of Directors for a two year term. Seconded by Jess R. All in favor.

Motion to adjourn the meeting at 12:29 pm made by Samantha and seconded by Suzie. All in favor.



The Corporation of the City of Vernon COUNCIL DISCRETIONARY GRANT APPLICATION FORM

Reset



IMPORTANT: The deadline for Council Discretionary Grant Applications are semi-annual being April 30 and October 31 each calendar year.

Applications will only be accepted during the intake periods of April 1 - April 30 and October 1 to October 31. Applications must be submitted to the Director of Financial Services no later than 4:00pm on the application deadline (April 30th and October 31st), if City Hall is closed that day, on the next working day that City Hall is open.

Applicants may run the risk of grant funding being depleted if waiting to apply until the October intake deadline.

If grant applications are received after the cut off periods they will be returned to the applicant and must be submitted at the next intake period.

Please note: Incomplete applications will not be considered

ORGANIZATION INFORMATION

NAME OF ORGANIZATION APPLYING FOR COUNCIL DISCRETIONARY GRANT:	Learning Disabilities Association Vernon Chapter
CONTACT PERSON:	Naidene Shannon
ORGANIZATION MAILING ADDRESS:	#102,3402, 27th Avenue Vernon BC V1T 1S1
BUSINESS PHONE:	250-542-5033
EMAIL ADDRESS:	ldavernon6@telus.net
REGISTERED NON PROFIT SOCIETY INCORPORATION NUMBER (required):	96624 5442 RR 0001

"Personal information contained on this form is collected under the *Freedom of Information and Protection of Privacy Act* and will be used only for the purposes of responding to your request".

**City Hall Address: 3400 30th Street, Vernon BC, V1T 5E6
Inquiries: 250-545-1361
Web: www.vernon.ca**



The Corporation of the City of Vernon COUNCIL DISCRETIONARY GRANT APPLICATION FORM

ORGANIZATION GOALS, OBJECTIVES AND ACTIVITIES:

The purpose and mission of the LDA Vernon is to operate a charitable organization and administer and employ its property, assets and resources for the exclusive purpose of advancing the education, general-well being and support of children, youth and adults with average and above average intelligence who have severe learning difficulty processing, retaining and or retrieving sensory information.

SERVICE PROVIDED TO THE COMMUNITY:

LDA Vernon's service provision's primary target is persons with a learning disability, as well tertiary targets of families and the community on whole, through the provision of customized learning programs aimed at positively impacting the future employment, health and well-being, and self-esteem of an at-risk group.

A PROFILE AND HISTORY OF THE ORGANIZATION AND ITS ACCOMPLISHMENTS:

Our association has been in existence in the Vernon Area since 1973. It was formed by a group of dedicated parents and Dr. Art Sovereign. Over the years we have offered an after school and summer tutoring programming for those students struggling with reading, writing, spelling and math. We provide information on Learning Disabilities and receive several inquiries on a weekly basis. These questions come from people in the entire Okanagan Valley with our main focus being the greater Vernon area. In the past year, we have received over 150 requests from both parents of children with a learning disability and from people wanting information on learning and developmental assessments, diagnoses, information on available tutoring programs, learning materials and potential referrals to relevant community services and partners. Vernon LDA provides counselling and advocacy to parents, guardians and the general public on Learning Disabilities. The favorable comments from the families we have been involved with serve as a testament to the success of our association.

PLEASE IDENTIFY THE STEPS YOUR ORGANIZATION HAS TAKEN TO ACQUIRE GRANTS FROM OTHER SOURCES:

The Vernon Learning Disabilities Association has a yearly fundraiser, we apply for grants from community based organizations. The North Okanagan Community Foundation, the Foord Foundation, the Book Warehouse, the Community Access Grant and personal donations have helped to fund our programs. We provide information on the programs available through our association and report on the use of the funds given to us. We are also willing to host workshops in our community to increase awareness on the support we provide in the local community.

City Hall Address: 3400 30th Street, Vernon BC, V1T 5E6
Inquiries: 250-545-1361
Web: www.vernon.ca



The Corporation of the City of Vernon

COUNCIL DISCRETIONARY GRANT APPLICATION FORM

GRANT REQUEST

(You may wish to provide attachments, please note below where these items can be found.)

<p><u>AMOUNT OF REQUEST:</u></p> <p>requested amount is \$4000.00 . \$2000.00 for supported tutoring bursaries for 4 students from January to April \$ 1000.00 rent \$1000.00 support materials/technology</p> <hr/> <p><u>IN-KIND SERVICES: (please describe and include cost)</u></p> <p>- see attachment</p>
<p><u>PURPOSE OF GRANT AND PROPOSED ALLOCATION OF FUNDS:</u></p> <p>The purpose of this grant is to enable people in our community to receive the support necessary to improve the learning environment for their child or children. In order to receive the support at no charge, parents apply for a tutoring bursary for their child. We endeavor to support the child as long as necessary. Parents and students are asked to evaluate the support given to their family.</p>
<p><u>BENEFITS TO COMMUNITY RESULTING FROM GRANT OR CITY GOALS AND OBJECTIVES THAT WILL BE MET, IF THE GRANT IS APPROVED:</u></p> <p>The anticipated result of the grant is to decrease the incidence of high school drop outs. Services provided under the grant will enable students to learn and apply the necessary strategies and skills to become successful both in school and in daily life.</p> <p>LDA Vernon's service provision's primary target is persons with a learning disability, as well tertiary targets of families and the community on whole, through the provision of customized learning programs aimed at positively impacting the future employment, health and well-being, and self-esteem of an at-risk group.</p>
<p><u>DEGREE OF COMMUNITY FINANCIAL SUPPORT OR SPONSORSHIP:</u></p> <p>The degree of community financial support has enabled our association to continue to support families that need support. With the financial support we are able to rent office space at the People Place, purchase researched based materials that have proven successful in improving literacy skills. We have introduced our students to technology such as voice to text and text to voice programs. We work closely with local schools whenever possible, receive referrals from the Literacy Society when specific instruction is warranted. The Foord Foundation and North Okanagan Community Foundation grants meant we could support 16 students over the summer months. LDA Vernon works towards establishing community partners, to coordinate services – cross organization referrals work to enhance service provision.</p>

City Hall Address: 3400 30th Street, Vernon BC, V1T 5E6
Inquiries: 250-545-1361
Web: www.vernon.ca

In Kind Contributions Summary

Name of Organization- Learning Disabilities Association- Vernon Chapter

Name of Program- Community Advocacy, Tutoring & Outreach Program

Organization's Fiscal Year- March 31st 2019-March 31st 2020

#of Volunteers doing volunteer labour x # of hours @\$20.00 per hour

- Yearly fundraising event: Total \$ 1,480.12
- 3 volunteers x 10 hours each
- 1 volunteer x 7 hours
- 2 volunteer x 5 hours
- 1 volunteer x 6 hours
- 2 volunteer x 4 hours
- 1 volunteer x 3 hours
- 2 volunteers x 2 hours
- 3 volunteers x 4 hours

- Office administration & chapter organizing: Total: \$2400.00

-5 x 12 days per year x2 hours each \$20.00 per hour

* Tutor prep, 2 tutors from April 1st to March 31st, 400 hours each @ \$20.00 per hour

Total \$16,000

* 1 tutor 200 hours @ \$20.00 per hour for 10 months

Total \$4,000.00

Total of in kind contribution:

- \$1480.12
- \$2400.00
- \$16,000.00
- \$4,000.00
- Total: \$23,880.12

Learning Disabilities Association of BC - Vernon Chapter
 Statement of Income and Expenses 27-Sep-19

General Account

General Account Balance 30-May-19 \$8,931.86

REVENUE

Interest \$0.29
 Membership \$215.00
 Donations \$6,000.00
 Grants/Legacies \$6,500.00

TOTAL REVENUE \$12,715.29
 EXPENSES

Office Expenses \$290.91
 Telephone \$132.41
 Rent \$843.15
 Insurance \$249.51
 Office Equipment/Resources \$352.05
 Tutoring Expenses \$46.23
 Tutoring Bursaries \$450.00
 Member Dues (People Place) \$25.00

TOTAL EXPENSES \$2,389.26

Revenue Minus Expenses \$10,326.03

General Account Balance 31-Aug-19 \$19,257.89

To Date: 27-Sept-19 Approx. \$18,324.45 ✓

Statement of Income and Expenses 27-Sep-19

Gaming Account

Gaming Account Balance 31-May-19 \$3,912.67

REVENUE Interest \$0.10

TOTAL REVENUE \$0.10

EXPENSES

Tutoring Bursary \$465.00
 Contracted Services \$745.00

TOTAL EXPENSES \$1,210.00

Revenue Minus Expenses -\$1,209.90

Gaming Account Balance 31-Aug-19 \$2,702.77

To Date: 27-Sept-19 Approx. \$1,921.72 ✓

Learning Disabilities Association of BC - Vernon Chapter
Statement of Income and Expenses
General Account
April 1, 2018 to March 31, 2019

REVENUE		
	Donations	\$7,029.00
	Legacy/Grants	\$1,042.36
	Garage Sales	\$1,239.00
	Membership	\$910.00
	GST Rebate	\$108.38
	Interest	\$0.91
	TOTAL REVENUE	<u>\$10,329.65</u>
EXPENSES		
	Membership Fees & Dues	\$25.00
	LDABC Membership Dues	\$180.00
	Office Expenses/Supplies	\$1,250.23
	Office Equipment	\$731.75
	Rent	\$2,743.60
	Telephone	\$511.06
	Insurance	\$920.36
	Advertising	\$27.68
	Contracted Services (office support)	\$560.00
	Minister of Finance	\$55.00
	Tutoring Expenses	\$67.35
	Supported Tutoring	\$2,055.00
	Honorariums & Bursaries	\$100.00
	GST Owed To Gaming Account	\$6.69
	GST Paid	\$119.89
	TOTAL EXPENSES	<u>\$9,403.61</u>
	Revenue Minus Expenses	\$926.04
	Surplus at Beginning of Year	\$6,973.01
	Surplus at End of Year	\$7,899.05

Gaming Account

REVENUE		
	Direct Access Deposit	\$5,000.00
	GST Rebate	\$6.69
	Interest	\$0.23
	TOTAL REVENUE	<u>\$5,006.92</u>
EXPENSES		
	Contracted Services	\$1,815.00
	Supported Tutoring	\$2,205.00
	Rent	\$548.72
	Educational Assessments	\$350.00
	GST Paid	\$13.38
	TOTAL EXPENSES	<u>\$4,932.10</u>
	Revenue Minus Expenses	\$74.82
	Surplus at Beginning of Year	\$4,125.08
	Surplus at End of Year	\$4,199.90

Anne M. Wellburn



**LEARNING DISABILITIES ASSOCIATION OF BC
VERNON CHAPTER**

**Minutes of the Annual General Meeting
held at the
People Place, on May 23rd, 2019.**

Present: (List of Attendees attached).

1. Meeting called to order at 7:10 pm, by President – Chris Panasiuk.
2. Motion of approval of *Agenda*, moved by Judy Rourke.
3. Motion of acceptance of *AGM Meeting Minutes*, of May 22, 2018, moved by Anne Wellburn, seconded by Judy Rourke.
4. Motion to Accept *Financial Report* as of March 31, 2018, moved by Anne Wellburn, seconded by Nancy Ingersoll. Carried.
General Account Balance: \$7,889.05.
Gaming account Balance: \$4,199.90. Full report attached.
5. **Committee Reports**
 - 5.1. *President's Annual Report/Tutoring Annual Report* - Chris Panasiuk.
 - 5.2. *Membership Annual Report* - Anne Wellburn.
 - 5.3. *Office Report – 2017/2018* - Vivienne Norris.
 - 5.4. *Education/Community Liaison Report* - Naidene Shannon.
 - 5.5. *Learning Disabilities Association of B.C. Report* - Nancy Ingersoll.
6. **New Business;**
 - 6.1. *Election of New Officers.* Elections run by Nancy Ingersoll.

The following people were elected by acclamation to positions on the Board of the LDA BC, Vernon Chapter.
President: Chris Panasiuk
President: Nancy Ingersoll
Wellburn
Judy Rourke.

Directors: Mariette ffolliott, Carol Bliss, Gail Hall.
7. Motion to adjourn at 7:20 pm, moved by Judy Rourke.

**Vice
Treasurer: Anne
Student Assessment Director:**

List of Attendees.

Chris Panasiuk

Nancy Ingersoll

Judy Rourke

Naidene Shannon

Anne Wellburn

Clara Tees

Vivienne Norris

Learning Disabilities Association of BC Vernon Chapter

Annual General Meeting Financial Overview

May 23, 2019

At April 1, 2018, the 2018/2019 beginning balance was \$6973.01 in our general account. Donations in the amount of \$7029 came in over the year with two major donations coming in July, \$4500 from the Foord Foundation, and \$1000 from Book Warehouse. Our garage sale raised \$1239 and we received an increase in the Art Sovereign Legacy Fund to \$1042.36 managed by the Community Foundation. Membership, GST rebate and interest added \$1019.29 and brought total revenue in the general account to \$10,329.65.

A total of \$9403.61 was paid out in expenses from the general account with the two largest expense items being rent and supported tutoring. An itemized list of expenses is attached. We ended our year on March 31, 2019 with a general account balance of \$7899.05.

Our gaming account showed a balance of \$4125.08 at April 1, 2018 which was the bulk of the gaming grant received in January 2018. This money was completely spent by December 2018 and we applied for and received another provincial gaming grant of \$5000 in January 2019. The gaming grant was, and continues to be, used toward supported tutoring, educational assessment, rent and contracted services for office support and educational and community outreach. Funds paid out of the gaming account totalled \$4932.10 and left a year-end balance of \$4199.90.

At our year-end, March 31, 2019, we showed total (both accounts) revenue of \$15,336.57 and total expenses of \$14,335.71.

Between our gaming grant and community grants, this year we have been able to offer supported tutoring to students in the amount of \$4260. This amount reflects our commitment to ensuring that local youth with learning disabilities receive the educational support they need and that cost need not be a deterrent.

Our financial position, despite a very small budget, remains stable.

Respectfully submitted,



Anne Wellburn

Vernon Learning Disabilities Association
President's Annual Report: May 2018 – May 2019
& Annual Tutoring Program Report

Thanks to the tireless efforts of 2 part time staff, our 7 member executive, 1 advisor, 3 teacher tutors and our members; we continue to provide support for children, youth and adults in many communities throughout the Okanagan Valley.

Many thanks to our supporters:

- Foord Foundation
- Direct Access Grant
- Tutoring Program
- Volunteers
- Memberships
- Personal Donations

Services We Provided:

- After school and summer one to one tutoring program: 13 students
- Support to local agencies in the way of providing information on learning disabilities
- Mentoring for youth and adults with learning disabilities (OUC student)
- Contact with teachers whose students we support
- Meeting with parents/guardians re advocacy for their children, diagnostic assessments and recommendations for at home support
- Student support in the form of student bursaries
- Covering the cost of tutoring for students whose parents are unable to pay for it (6 students)
- From these supported tutoring funds the cost of Psychoeducational Assessments (2 this year) and Evaluation Reports when necessary
- Training Session and development of a Manual provided for our teacher tutors on the use of Speech to Text Program for our Intermediate students
- On-going efforts to provide awareness throughout the Okanagan Valley

Ongoing Community Partnerships:

- North Okanagan Literacy Society
- NOYFSS
- Teachers and Case Managers for students with Learning Disabilities in School District 22
- Learning Disability Association of BC

Goals for the coming year:

Continue to:

- Update materials for our professional lending library and our tutoring program
- Keep accurate stats on our volunteer hours and services offered
- Offer one to one tutoring after school September to June and in the summer under the guidance of experienced Teacher/tutors
- With the help of Grants and an annual fund raiser to provide supported tutoring to parents who are unable to cover the cost of tutoring
- Increase the use of technology ie. Speech to Text Program with our Intermediate students in the tutoring program
- Update our members with the monthly Newsletter on upcoming events and current information about learning disabilities
- Hold an annual fund raiser (Kal Event/2018)

It is a privilege to work with this incredible group of people dedicated to improving the lives of those affected with learning disabilities.

Respectfully submitted by,

Chris Panasiuk President Vernon Learning Disabilities
& Tutoring Program Co-ordinator



**Learning Disabilities Association of BC
Vernon Chapter
Annual General Meeting
May 23rd, 2019.**

Office Report.

In the past year, I have worked on;

- office correspondence, largely online, and phone calls.
- office garbage and recycling.
- production of the local chapter newsletter and distribution to membership and to the parents of students in our programs. Topics covered are based on research done by Naidene Shannon. Anxiety has been something of a focus.
- advertising and notification of upcoming events, seminars and workshops etc. for other related community organizations.
- preparations for Executive meetings, including Minutes and reminders of meetings, using Action statement reminders.
- preparation for, and attendance at, The Alternative Gift Fair. Although the event was not well-attended, we were able to make some community members aware of our existence and our mission.
- During 2019 much of my work has focused on The Pub Night at the Kal Sports Bar. This was very much a learning experience involving a lot of forward planning, and the achievement of those plans. I have very much appreciated those members of the Executive who stepped up to help with the planning, to volunteer to take responsibility for multiple tasks, and to carry out those tasks in a timely fashion. It has been an interesting way to observe the strengths that each of us has. When we work together, showing respect for the individual skills and abilities each of us has, and offering to use those to help our cause, the effort is very rewarding.



Vivienne Norris
Office Support.

**Learning Disabilities Association of B.C. (Vernon Chapter)
Annual General Meeting – May 23, 2019
Membership Report**

Our Vernon Chapter has fifty-two members in total. This breaks down into three categories:

Executive Members - The Board of Directors currently has seven members. These members form our executive.

General Members – Our General Membership is thirty-one and has remained constant over the past year. The membership fee of twenty-five dollars allows members to have access to our resource room lending library, receive Chapter newsletters and current information items and they are eligible to vote. Two of this number are Life members.

Associate Members – Fifteen members, again no change from last year. While they are not eligible to vote their five dollar membership helps demonstrate community support.

Total Membership – Fifty-two members

Eligible Voting Members - Thirty-seven

We are fortunate to have a dedicated membership that has kept our numbers at the same level over the past few years.

While we continue to support LDABC with a five dollar donation from each full membership, there was considerably less work this year as I remitted once, at our year-end in March, rather than monthly.

Although we still struggle with the dilemma of how to attract new and younger members, the current members are committed to supporting our association and many turn out for LDA Vernon events.

Our membership numbers show that there is strong interest in, and support for, our programs. When applying for funding and accounting for funds received it is important to demonstrate solid community backing.

Membership fees of \$910.00 came in over the past year and this money also helps maintain our office and supports youth and adults with learning disabilities.

Respectfully submitted,

Anne Wellburn

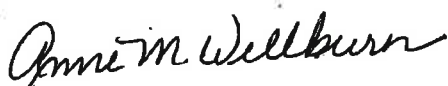

Educational/community liaison report for 2018-2019**• Fundraising:**

- We took part in the JVC alternative fair at the Schubert Center in October
- A report was submitted to the Foord Foundation in April outlining the use of their funds from their 2018 grant
- A grant request was submitted to the Foord Foundation for the coming year requesting \$4500.00 for our supported tutoring program
- We applied to the North Okanagan Community Foundation for a grant and received \$2000.00 for our summer tutoring program, the presentation takes place at the end of April
- A summary will be included in our application for the Community Gaming Grant for the volunteer hours associated with fund raising activities (in August)
- Our recent fund raiser at the Kai was very successful

• Community partnerships:

- NOYFSS
- V Learn
- Local schools
- Literacy Society

• Advocacy:

- Respond to and meet with parents and clients on the services of LDA
- Respond to emails and phone calls from people in the province wanting information on Learning Disabilities

• Education

- Work closely with the tutor program coordinator to review educational assessments
- Research and purchase new researched based educational materials
- Work closely with Viv (office support) for newsletter information
- Review and update Community Advocacy Program
- Review and explain educational assessments to parents
- Provide information to parents on IEPs when requested
- Meet with parents to set up home programs
- Research appropriate websites for parents

Submitted by Naidene Shannon Educational/Community Liaison



LDABC ANNUAL REPORT TO LDA VERNON,

2019

LDABC's mission is to advance the education, employment, social development, legal rights and general well being of people with learning disabilities in the province of British Columbia. LDABC continues to focus its research and advocacy efforts on four areas: access to assessment, early diagnosis and remediation, teacher training and equitable access to education. 'Live Learning', which allows students, on a computer, to build their skills as an addition to one-on-one tutoring or while they are on a waiting list continues. Information, resources and current news regarding webinars and conferences, along with a video about LDABC, can be found on the website www.ldabc.ca. Also, check out Facebook for Learning Disabilities Association of BC and Learning Disabilities Association of Vernon BC.

LDA Canada launched the new website www.ldac-acta.ca last year. LDAC sends out 4 newsletters a year with interesting reports from chapters across Canada. The website contains resources and information for parents and professionals and blogs referring to the latest research around LD and the brain.

I enjoy working with such dedicated individuals from our Vernon Board and from LDABC. Thank you.

Respectfully Submitted,
Nancy Ingersoll

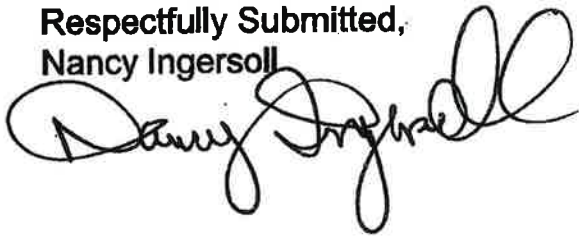

Literacy Society

 of the North Okanagan

City of Vernon
Director of Financial Services
3400 30th Street, Vernon, BC
V1T 5E6



October 8, 2019

Dear Director;

Please accept the enclosed Discretionary Grant application for a Financial Literacy data-base.

Financial wellness and security are hallmarks of healthy communities. In these uncertain economic times, everyone needs to be more vigilant with their resources. Youth will be particularly challenged to make sound decisions and will need support. This support is important to future economic development.

We are working with community partners to address an identified gap in financial literacy. This project is directed at youth, but has universal applications that would potentially benefit more community members.

The project is part of a larger strategy, but is an essential first step to bringing together information and resources already available in the community, making them accessible to those seeking them.

Knowledge, along with confidence, are the best predictors of healthy financial behaviour.

I am confident that this project will be a useful tool for our community groups serving children, youth, new comers, adults, seniors, and their service providers.

Thank you for considering our request. I am happy to answer any questions that may arise from the application.

Sincerely,

Wendy Aasen



Executive Director

Literacy Society of the North Okanagan
303-3402-27th Avenue (People Place), Vernon, BC V1T 1S1
Phone: 250.275.3117
www.literacysociety.ca info@literacysociety.ca





The Corporation of the City of Vernon COUNCIL DISCRETIONARY GRANT APPLICATION FORM

IMPORTANT: The deadline for Council Discretionary Grant Applications are semi-annual being April 30 and October 31 each calendar year.

Applications will only be accepted during the intake periods of April 1 - April 30 and October 1 to October 31. Applications must be submitted to the Director of Financial Services no later than 4:00pm on the application deadline (April 30th and October 31st), if City Hall is closed that day, on the next working day that City Hall is open.

Applicants may run the risk of grant funding being depleted if waiting to apply until the October intake deadline.

If grant applications are received after the cut off periods they will be returned to the applicant and must be submitted at the next intake period.

Please note: Incomplete applications will not be considered

ORGANIZATION INFORMATION

NAME OF ORGANIZATION APPLYING FOR COUNCIL DISCRETIONARY GRANT:	Literacy Society of the North Okanagan
CONTACT PERSON:	Wendy Aasen, Executive Director
ORGANIZATION MAILING ADDRESS:	#303- 3402 27th Avenue, Vernon, BC V1T 1S1
BUSINESS PHONE:	250.275.3117
EMAIL ADDRESS:	ed@literacysociety.ca
REGISTERED NON PROFIT SOCIETY INCORPORATION NUMBER (required):	89739 7154 RR0001

"Personal information contained on this form is collected under the *Freedom of Information and Protection of Privacy Act* and will be used only for the purposes of responding to your request".

City Hall Address: 3400 30th Street, Vernon BC, V1T 5E6
Inquiries: 250-545-1361
Web: www.vernon.ca



The Corporation of the City of Vernon COUNCIL DISCRETIONARY GRANT APPLICATION FORM

ORGANIZATION GOALS, OBJECTIVES AND ACTIVITIES:

The Literacy Society of the North Okanagan works with community partners to provide literacy support for children and adults. We help to fill identified gaps and to address the learning and literacy needs in the community.

In addition to the below programs/projects, we also lead an Adult Literacy network for our community partners who serve adults with various learning needs. We run a volunteer computer support program in partnership with the library. Adults can get one on one support with their technology needs by booking a one hour appointment.

SERVICE PROVIDED TO THE COMMUNITY:

We provide programs and services such as:

Books for Babies and Kindies - families are gifted with a new book for their child during immunizations. This is partnership with the Public Health Nurses at the Health Unit.

Early Learning Action team - We work with our Early Learning community partners to identify gaps and concerns and develop initiatives to address them. For example, we developed a "Be Screen-Free with Me" campaign to encourage parents to spend more screen-free time with their toddlers and pre-schoolers. We also provided financial literacy workshops for families.

We provide two school-based programs for students who are struggling with their reading. The Reading Together program place volunteers in elementary schools to read with children to boost their confidence. Hundreds of volunteers and students benefit. We also offer small-group and private tutoring at no charge to families and help about 100 students in this way each year.

A PROFILE AND HISTORY OF THE ORGANIZATION AND ITS ACCOMPLISHMENTS:

The Literacy Society of the North Okanagan was formerly known as the Junction Literacy Centre or the Literacy and Youth Initiatives Society of the North Okanagan. From 2007 to 2017, the Society also managed Teen Junction Youth Centre and shared a building space. In 2017, it was the decision of the Board that the Youth would be better served by the Okanagan Boys and Girls Club, as the needs of the youth were growing and the OBGC were experienced in this respect. This was a win-win, as it allowed the Literacy Society to focus on literacy programming, while ensuring that the Youth programs would continue in good hands. Currently, the Literacy Society has offices in the People Place.

Over the years, the organization has built good relationships in the community, working in partnership to serve the community's literacy and learning needs as capacity allows.

We also host the Annual Adult Spelling Bee Challenge fundraiser each year of which the City has been a long-time supporter of.

PLEASE IDENTIFY THE STEPS YOUR ORGANIZATION HAS TAKEN TO ACQUIRE GRANTS FROM OTHER SOURCES:

Working with our community partners, we have identified that there is a need to empower people with Financial Literacy. This is a gap shared across all ages and stages from school-age to seniors.

To date, a Steering Committee has formed and developed a strategy to address financial literacy gaps among youth. The Steering Committee is just now collectively looking at how we can fund the identified initiatives. We plan to approach financial institutions, the Vancouver Foundation, and possibly apply for a JCP grant to help staff it.

City Hall Address: 3400 30th Street, Vernon BC, V1T 5E6
Inquiries: 250-545-1361
Web: www.vernon.ca



The Corporation of the City of Vernon

COUNCIL DISCRETIONARY GRANT APPLICATION FORM

GRANT REQUEST

(You may wish to provide attachments, please note below where these items can be found.)

AMOUNT OF REQUEST:

\$5000

The funds would be used to build the foundation of the below mentioned data-base, including research and outreach in the community. We would hire a candidate who would benefit from this work experience. We will also seek additional grants should the project grow beyond what the \$5000 will cover.

IN-KIND SERVICES: (please describe and include cost)

The Literacy Society of the North Okanagan is committed to facilitating and leading the Steering Committee through the process of community development. To date, this initiative is supported by SD#22, Career Prep and Open Door programs, Community Futures/WorkBC, NexusBC, and a number of financial institutions. We also have the interest of Vernon and District Immigrant Community Service Society, Okanagan College, Independent Living, Vernon, and the North Okanagan Friendship Society. We expect that this list will grow.

PURPOSE OF GRANT AND PROPOSED ALLOCATION OF FUNDS:

One of the initiatives identified was to build a local data-base of financial literacy resources and compile them as a one-stop source for local service providers.

This resource would help schools, employment program providers, seniors organizations, and other family service providers, access workshop facilitators, courses and curriculums, volunteers, and other support available in the community. It is expected that it would grow to also become part of a Financial Literacy HUB that would be located at the Okanagan Regional Library, for general public access.

Additionally, the data-base would be part of a larger volunteer "mentorship" program that would provide broader support to youth transitioning out of other support programs, when they are vulnerable and need the confidence and knowledge to make sound financial decisions.

BENEFITS TO COMMUNITY RESULTING FROM GRANT OR CITY GOALS AND OBJECTIVES THAT WILL BE MET, IF THE GRANT IS APPROVED:

The benefits to the community would be that more youth would be empowered with financial knowledge, confidence, and support as they enter the workforce, start college, or start their own business. Often when youth leave supportive programs, such as Community Future's WorkBC "Employ" program, they are often still needing support to be successful. The mentorship program is meant to help ensure that they don't "fall between the cracks".

As more youth are successful in this transition, they become earning, contributing community members, and more likely to achieve financial wellness in difficult economic times.

DEGREE OF COMMUNITY FINANCIAL SUPPORT OR SPONSORSHIP:

Other than in-kind, given that the initiative is very new, no other financial support has been confirmed. That said, various sources will be explored and applied for as capacity and timing allow. We have applied to Telus for another component of the project - a information kiosk, that can be populated with Financial Literacy apps that could be used at employment fairs, school and community events.

City Hall Address: 3400 30th Street, Vernon BC, V1T 5E6
Inquiries: 250-545-1361
Web: www.vernon.ca



The Corporation of the City of Vernon

COUNCIL DISCRETIONARY GRANT APPLICATION FORM

DEGREE OF DEMONSTRATED ECONOMIC DEVELOPMENT, ENVIRONMENTAL STEWARDSHIP OR SOCIAL BENEFIT THAT MAY BE GENERATED BY THE AWARD OF A COUNCIL DISCRETIONARY GRANT:

This project speaks directly to economic development. It is recognized that Canadians are lacking in regards to their financial literacy, but more so, confidence has been identified as important to healthy financial behaviour. We hope to make it easier for youth/adults to address their financial literacy gaps, by making it more accessible in the schools and community, removing some of the barriers around it (we are working with financial institutions to be part of this approach), and helping to build confidence and empowerment. Community mentors with a background in financial expertise and experience will be available to help the more vulnerable community members take steps to a better financial future.

GRANT QUALIFICATION CHECKLIST (please check all that apply):

- Community Based
- Providing a service which is not provided by any other group or organization within the City or which is provided for in another municipality and used by residents
- Must only submit one application per calendar year
- Grant request is not to cover retroactive funding or to cover a deficit

Note: Organizations do not qualify for the discretionary grant program if they are in receipt of regional funding or are receiving grants or other assistance from the City of Vernon.

GRANT REQUIREMENTS (please attach to your grant application):

- Most Recent Set of Financial Statements
- Minutes of Most Recent Annual General Meeting
- List of Members of the Executive (including positions held, address and contact numbers)

In the case of newly formed groups, a budget and information regarding the organization purpose including list of Board of Directors will be sufficient.

October 08, 2019

Date

Wendy Case

Signature

October 8, 2019

City Hall Address: 3400 30th Street, Vernon BC, V1T 5E6
Inquiries: 250-545-1361
Web: www.vernon.ca

Financial Statements of

**LITERACY SOCIETY OF THE
NORTH OKANAGAN**

(Formerly Literacy and Youth Initiatives Society of the North Okanagan)

Year ended July 31, 2018

(Unaudited - See Notice to Reader)

LITERACY SOCIETY OF THE NORTH OKANAGAN
 (formerly Literacy and Youth Initiatives Society of the North Okanagan)

Statement of Financial Position

July 31, 2018, with comparative figures for 2017
 (Unaudited - see Notice to Reader)

	2018	2017
Assets		
Current assets:		
Cash	\$ 267,255	\$ 291,151
Accounts receivable	2,401	2,847
Prepaid expenses	429	411
	<u>270,085</u>	<u>294,409</u>
Capital assets (Note 3)	4,616	5,770
	<u>\$ 274,701</u>	<u>\$ 300,179</u>

Liabilities and Net Assets

Current liabilities:		
Accounts payable and accrued liabilities	\$ 3,533	\$ 14,758
Government remittances payable	1,530	1,754
Deferred revenue (Note 4)	43,039	47,848
	<u>48,102</u>	<u>64,360</u>

Net assets:		
Externally restricted (Note 2)	14,514	21,668
Internally restricted (Note 2)	100,000	17,291
Invested in capital assets	4,616	5,770
Unrestricted	107,469	191,090
	<u>226,599</u>	<u>235,819</u>
	<u>\$ 274,701</u>	<u>\$ 300,179</u>

APPROVED ON BEHALF OF THE BOARD:

 Director

The recognition, measurement, presentation and disclosure principles in these financial statements may not be in accordance with the requirements of any of the financial reporting frameworks in the CPA Canada Handbook - Accounting.

See accompanying notes to the financial statements

LITERACY SOCIETY OF THE NORTH OKANAGAN
(formerly Literacy and Youth Initiatives Society of the North Okanagan)

Statement of Changes in Net Assets

July 31, 2018, with comparative figures for 2017
(Unaudited - see Notice to Reader)

	Invested in Capital Assets	Externally Restricted Net Assets	Internally Restricted Net Assets	Unrestricted Equity	Total 2018	Total 2017
Balance, beginning of year	\$ 5,770	\$ 21,668	\$ 17,291	\$ 191,090	\$ 235,819	\$ 390,167
Excess (deficiency) of revenue over expenditures	(1,154)	-	-	(8,066)	(9,220)	(143,962)
Transfer of youth surplus to Okanagan Boys and Girls Club	-	-	-	-	-	(10,386)
Change in Restricted Net Assets	-	(7,154)	82,709	(75,555)	-	-
Balance, end of year	\$ 4,616	\$ 14,514	\$ 100,000	\$ 107,469	\$ 226,599	\$ 235,819

The recognition, measurement, presentation and disclosure principles in these financial statements may not be in accordance with the requirements of any of the financial reporting frameworks in the CPA Canada Handbook - Accounting.

See accompanying notes to the financial statements

LITERACY SOCIETY OF THE NORTH OKANAGAN
(formerly Literacy and Youth Initiatives Society of the North Okanagan)

Notes to Financial Statements
July 31, 2018

(Unaudited - see Notice to Reader)

4. Deferred revenue

Deferred revenue consists of funds received in the current year to be used for programs in a subsequent year. These funds are restricted to specific programs as follows:

	2018	2017
Community gaming grant	\$ 14,514	\$ 20,706
Decoda Literacy Solution - Literacy coordination	13,477	13,477
Foord Family Foundation - After School Reading Program	6,000	-
Family Resource Centre - Financial Literacy Program	3,083	994
Foord Family Foundation - Educational Enhancement Project	2,549	3,277
Screen Smarts	1,498	-
Dr. Hardy - Skills Boost Program	1,380	1,968
Toronto Dominion Bank - Skills Boost Program	538	176
Royal Bank of Canada - One to One program	-	5,000
Community Futures of the North Okanagan - Books for Babies	-	2,000
United Way of the North Okanagan - Computer Literacy Program	-	250
	<u>\$ 43,039</u>	<u>\$ 47,848</u>

5. British Columbia Societies Act

On November 28, 2016 the new British Columbia Societies Act came into effect. Included in the new Act is a requirement to disclose the remuneration paid to all directors, the ten highest paid employees, and all contractors who were paid at least \$75,000 annually. The Society had no individuals who met this criteria for the year ended July 31, 2018.

6. Comparative Figures

The prior year figures include revenue and expenses for ten months of the operations of a youth drop-in centre. As at May 31, 2017 the operations of the youth drop-in centre were taken over by an unrelated charity organization and the building was sold.

Literacy Society

of the North Okanagan

Annual General Meeting, November 6, 2018 - Minutes

In Attendance:

Betty Gallant (D)	Chris Hart (D)	Betty Beck (M)
Morgan Grant (M)	Kathy Wickum	Katherine Mortimer (M)
Sharron McDougall (M)	Bill Miller (D)	Kim Hutton (Accountant)
Paul Philp (D)	Robert Tannahill (D)	James Quigg (M)
Wanda Fisher (M)	Gary Fisher	

(M) Member (D) Board member

Regrets: Debra Law (D), Vernon Learning Disabilities (M), Barb Overend (M)

1. 4:34 pm – Meeting called to order – President, Chris Hart
2. Approval of Agenda
MOTION: Chris Hart **Second:** Bill Miller, Betty Gallant **PASSED**
3. Adoption of Minutes from AGM – November 6, 2017
MOTION: Chris Hart **Second:** Robert Tannahill, Will Spisso **PASSED**
4. Presentation of 2017/18 Financial Statements – Notice to Reader prepared and presented by Kimberley Hutton, CPA, CA
 To waive appointment of an Auditor for 2018/19 fiscal year
MOTION: Chris Hart **Second:** Bill Miller, Morgan Grant **PASSED**
5. President's Report, an overview of the year was provided by President, Chris Hart
7. Executive Director and Staff Program Reports – provided by Literacy Staff
9. Report from Betty Beck from the Adult Technology Support Program at Vernon Library.
8. Election of Officers for 2018/19
 Standing: Chris Hart, Bill Miller, Debra Law, Betty Gallant, Will Spisso, Stephen Cook, and Pat Loehndoff
 By acclamation for current directors to stay in place
MOTION: Chris Hart **Second:** Wanda Fisher, Morgan Grant **PASSED**
9. Meeting adjourned: 5:22 pm



The Corporation of the City of Vernon

COUNCIL DISCRETIONARY GRANT APPLICATION FORM

IMPORTANT: *The deadline for Council Discretionary Grant Applications are semi-annual being April 30 and October 31 each calendar year.*

Applications will only be accepted during the intake periods of April 1 - April 30 and October 1 to October 31. Applications must be submitted to the Director of Financial Services no later than 4:00pm on the application deadline (April 30th and October 31st), if City Hall is closed that day, on the next working day that City Hall is open.

Applicants may run the risk of grant funding being depleted if waiting to apply until the October intake deadline.

If grant applications are received after the cut off periods they will be returned to the applicant and must be submitted at the next intake period.

Please note: Incomplete applications will not be considered

ORGANIZATION INFORMATION

NAME OF ORGANIZATION APPLYING FOR COUNCIL DISCRETIONARY GRANT:	North Okanagan Cycling Society
CONTACT PERSON:	Jeffrey Palatnick
ORGANIZATION MAILING ADDRESS:	[REDACTED]
BUSINESS PHONE:	[REDACTED]
EMAIL ADDRESS:	okcycling@gmail.com
REGISTERED NON PROFIT SOCIETY INCORPORATION NUMBER (required):	S-49898

"Personal information contained on this form is collected under the *Freedom of Information and Protection of Privacy Act* and will be used only for the purposes of responding to your request".

City Hall Address: 3400 30th Street, Vernon BC, V1T 5E6
Inquiries: 250-545-1361
Web: www.vernon.ca



The Corporation of the City of Vernon

COUNCIL DISCRETIONARY GRANT APPLICATION FORM

ORGANIZATION GOALS, OBJECTIVES AND ACTIVITIES:

The North Okanagan Cycling Society's (NOCS) mission is to create positive trail experiences for mountain bikers in the North Okanagan. The society works collaboratively with its membership, local and provincial governments and the community to develop and protect bike trail that is safe and enjoyed by a variety of different stakeholders. NOCS aims to give mountain bikers a voice in our local community and increase accessibility to mountain biking for all ages and demographics.

SERVICE PROVIDED TO THE COMMUNITY:

NOCS provides key services to the community regarding trails and access to sport and recreation. The services provided by NOCS promote Vernon as a premier destination for mountain biking and supports recreation and healthy living within the community. Specific services provided to the community include:

- Membership base completes over 2000 volunteer hours annually.
- Collaborates with BC Parks, private landowners, local districts and governments to advocate and plan for new trails.
- Organizes weekly group rides held in the local trail systems with turnouts between 100-200 participants.
- Maintains and manages over 400km of multi-use trail in the Greater Vernon Area used by bikers, runners, hikers, dog-walkers and horseback riders.
- Hosts and assists with numerous special events throughout the year including the Vernon Bike Festival and the Liv Bombshell Women's Only Enduro. Trails maintained by NOCS are also used to host the Dirty Feet trail running race, Kalamalka Aquaterra and the Freaky Creaky Fondo.
- Collaborates, partners and supports all youth mountain biking programs in the community such as iRide, Sprockids, high school mountain bike teams and both the Trail Ninjas and G-Ninjas programs.

A PROFILE AND HISTORY OF THE ORGANIZATION AND ITS ACCOMPLISHMENTS:

NOCS was established in 2005 in order to unify bike related stakeholders in the North Okanagan. The original goal was to build a relationship with BC Parks to legitimize the process of trail building and increase mountain biking access in Vernon. The following are some recent accomplishments:

- Club membership has grown to a 1000+ members (2019).
- Developed and currently maintains multi-use trail system within 3 provincial parks (Kalamalka Lake, Ellison and Sovereign) that totals over 400km's of multi use trail in the Greater Vernon Area.
- Over 2500 hours of volunteer work is completed annually by our membership.
- Completed it's biggest capital project to date with the opening of the Vernon Bike Skills Park.
- Ambassadors for sustainable development and stewardship within the region.
- Directs the mountain bike community's enthusiasm and passion for riding opportunities to be in line with the regions and BC Park's mandate, values and processes.
- Promotes Vernon as a destination for mountain bike recreation and tourism, currently ranked by Trail-Forks as a "Top 10 ridden Canadian City."

PLEASE IDENTIFY THE STEPS YOUR ORGANIZATION HAS TAKEN TO ACQUIRE GRANTS FROM OTHER SOURCES:

- \$10,748 fund raised through membership donations (currently held in trust by BC Parks within the Park Enhancement Fund (PEF)).
- \$5,000 awarded for BC Parks Volunteer Group of the Year Award (2019).

City Hall Address: 3400 30th Street, Vernon BC, V1T 5E6

Inquiries: 250-545-1361

Web: www.vernon.ca



The Corporation of the City of Vernon

COUNCIL DISCRETIONARY GRANT APPLICATION FORM

GRANT REQUEST

(You may wish to provide attachments, please note below where these items can be found.)

AMOUNT OF REQUEST:

NOC's is currently seeking \$5000.

IN-KIND SERVICES: (please describe and include cost)

N/A

PURPOSE OF GRANT AND PROPOSED ALLOCATION OF FUNDS:

The purpose of the grant is to assist with funding the completion of a brand new professionally built mountain bike trail within Kalamalka Provincial Park.

BENEFITS TO COMMUNITY RESULTING FROM GRANT OR CITY GOALS AND OBJECTIVES THAT WILL BE MET, IF THE GRANT IS APPROVED:

The proposed trail is currently approved by BC parks to provide a "Blue Flow Trail" choice for trail users in Kalamalka Lake Provincial park. This would improve accessibility by creating a new trail for beginner to intermediate trail users. Recreation and healthy living is a key component of the city of Vernon's strategic plan. This trail will benefit the various user groups and events that utilize the Kalamalka Park trail network. This trail will be an asset to the community and a destination trail that will further promote mountain bike tourism in Vernon.

DEGREE OF COMMUNITY FINANCIAL SUPPORT OR SPONSORSHIP:

BC Wildfire Branch has completed in-kind tree falling services for the project. This is valued at approximately \$4000.00 and represents 10% of the total cost of the trail project

- NOCS members will also be completing 200 hours of volunteer work this fall to complete tree falling to facilitate a spring trail build.
- NOCS membership base will be responsible for 600 hours of volunteer labour to support Contour Trails Ltd. during trail construction.

- \$10,748 fund raised through membership donations, currently held in trust by BC Parks through the Park Enhancement Fund (PEF).

- \$5569 fund raised from 2019 movie premier event.
- \$4346 fund raised from weekly toonie rides and NOCS merchandise sales.
- \$5,000 awarded for BC Parks Volunteer Group of the Year Award (2019).

City Hall Address: 3400 30th Street, Vernon BC, V1T 5E6

Inquiries: 250-545-1361

Web: www.vernon.ca



The Corporation of the City of Vernon

COUNCIL DISCRETIONARY GRANT APPLICATION FORM

DEGREE OF DEMONSTRATED ECONOMIC DEVELOPMENT, ENVIRONMENTAL STEWARDSHIP OR SOCIAL BENEFIT THAT MAY BE GENERATED BY THE AWARD OF A COUNCIL DISCRETIONARY GRANT:

In 2018 an economic impact study, conducted by the Mountain Bike Tourism Association (MTBA) and Destination British Columbia, shows an increase of over 100% in revenues and employment numbers related to mountain biking in B.C. over a ten year period. Revenues rose from \$31.7 million to \$70.6 million while employment rose from 309 jobs to 687 jobs directly related to mountain bike tourism in the province. Vernon and the greater Okanagan are well positioned to benefit economically from this booming sector of the tourism economy.

This new recreation trail will improve accessibility to the Kalamalka Park trail network and will continue to promote sustainable recreation and active living in the local community. This trail will also be an important asset in the growth of current and future events in Vernon such as the Liv Bombshell Enduro, Vernon Bike Festival, Dirty Feet trail running race, Kettle Mettle, Kalamalka Aquaterra and the Freaky Creaky Fondo to name a few.

GRANT QUALIFICATION CHECKLIST (please check all that apply):

- Community Based
- Providing a service which is not provided by any other group or organization within the City or which is provided for in another municipality and used by residents
- Must only submit one application per calendar year
- Grant request is not to cover retroactive funding or to cover a deficit

Note: Organizations do not qualify for the discretionary grant program if they are in receipt of regional funding or are receiving grants or other assistance from the City of Vernon.

GRANT REQUIREMENTS (please attach to your grant application):

- Most Recent Set of Financial Statements
- Minutes of Most Recent Annual General Meeting
- List of Members of the Executive (including positions held, address and contact numbers)

In the case of newly formed groups, a budget and information regarding the organization purpose including list of Board of Directors will be sufficient.

October 30, 2019

Date

Jeffrey Palatnick

Signature

North Okanagan Cycling Society
Statement of Operations
January 1 – September 30, 2019

Revenue	Total
Membership	\$22,400.99
Liv Women's Enduro	\$14,009.00
Toonies/Socks	\$8,295.27
Movie Night	\$7,828.84
Ninjas Program	\$4,832.83
Sponsorship	\$3,225.00
Trail Maps App	\$87.50
Trailforks Karma (stripe)	\$25.00
Total Revenue	<u>\$60,704.43</u>
Expenditures	
Liv Women's Enduro	\$11,509.15
Oasis Insurance	\$10,075.00
Five Yr Strategic Plan	\$10,006.00
Trail Ninjas	\$7,015.61
TTF's	\$3,628.80
NOCS Socks	\$2,887.50
Trail Days/Maintenance	\$2,542.16
Movie Night	\$2,260.29
Admin Fees	\$1,383.75
Bike Fest	\$1,220.25
Membership Decals	\$1,054.26
BBQ's	\$899.56
Trail Building	\$399.74
Tools	\$278.27
Toonies/Food Costs	\$162.13
Membership Refunds	\$153.44
Signage	\$132.20
Total Expenditures	<u>\$55,608.11</u>
Excess of Revenue Over Expenditures	<u>\$5,096.32</u>

North Okanagan Cycling Society
Balance Sheet
09/30/19

ASSETS

Current Assets		
Operating Account	\$59,195.13	
Class A Membership Equity	\$25.00	
Class D Allocation Equity Shares	\$11,50	
Total Cash		\$59,231.63
Total Pay Pal Account		\$1,408.13
AR		
Total Current Assets		<u>\$60,639.76</u>
Other Assets		
Total Other Assets		\$0.00

TOTAL ASSETS

\$60,639.76

LIABILITIES

Current Liabilities		\$0.00
Total Current Liabilities		<u>\$0.00</u>

EQUITY

Share Capital		
Common Shares		\$36.50
Total Share Capital		<u>\$36.50</u>
Retained Earnings		
Retained Earnings Previous Year		\$55,506.94
Current Earnings		\$5,096.32
Total Retained Earnings		<u>\$60,639.76</u>

TOTAL EQUITY

\$60,639.76

LIABILITIES AND EQUITY

\$60,639.76

2020 Budget

Revenue

Membership	25,000
Liv Bombshell	15,000
PEF Volunteer Fund	5,000
Toonies	5,000
Trail Ninajs	5,000
Movie Night	4,000
Ratio Bike Fest	500
Total Revenue	59,500

Expenses

Neptune	39,000
Liv Bombshell	13,000
Insurance	12,500
Brushing	3,500
Trail Ninjas Coaching	3,000
Movie	1,800
Stickers	1,200
Trail Ninjas Jerseys	1,200
Youth Development	1,200
Toonie Expenses	1,000
Admin Fees	1,000
WCB Fees	275
Post Office Box	200

Total Expenses **78,875**

NET INCOME **(19,375)**

North Okanagan Cycling Society
Annual General Meeting
February 28, 2019, 7:00 p.m.
Lakers Clubhouse, Vernon, BC V1H 1M2

Board Members Present: Matt Ball, Dave Boutillier, Mark Dowhaniuk, Stacey Banks, Demian Carson, Nick Macdonald and Tom Eyres
Regrets: Dan Poulin, Nicole Guerrero

Meeting commenced at 7:30 pm
Chair and primary presenter unless otherwise stated is: Matt Ball

NOCS Board Member Introductions

Review of Membership Benefits and NOCS Strategy

Review of Accomplishments in 2018 including:

- Over 800 members paid in 2018
- Continued voice for mountain biking in the North Okanagan
- Weekly group rides
- Over 2000 hours of documented volunteer labor
- Renewed agreements with BC Parks; thanks to attendance and presence at BC Parks Kal Park information session
- Renewed agreements with Rec Sites and Trails BC, Noble Canyon update
- Lobbied for construction of new trail "Soup to Nutz" (Sovereign), Black Powder re-route and Granite (Ellison)
- Successful trail days /maintenance: Twisted Sister, Stone Free, Blister Sister, Rock is the New Berm and Threads had extensive work done
- Support of Sprockids, Trail Ninjas, Academy G Team and Trail Crew, IRide School Program
- Continuing relationship with Tourism Vernon and City of Vernon to establish Vernon as a Bike Destination ("Sage Brush Singletrack")
- Trail signage program was completed in Cosens Bay MTB Area of Kal Park and Sovereign Park
- Successful bike infrastructure lobbying for 2021 RDNO Ranchlands trail development(\$100K), Phase I of Becker Park Skills Park completed

Thanks to our sponsors:

Olympia, Sun Country Cycle, Skyride and all toonie ride food sponsors including Carson Therapy, Coldstream Construction, Vernon Toyota, City of Vernon, Thrive Physiotherapy, Sovereign Lake, Priest Valley Physio, Kawakubo, Bluebird Sport & Spine, Predator Ridge, Paradigm Naturopathic, The Red Antler, Nixon Wenger, SpeedPro Signs, Silver Star

Trail Ninjas: Dave Boutillier

Review of 2018 Programs and announcement of 2019 programs

Coordinated by Wade Garrod, Nicole Guerrero and David Boutillier

Trail Maintenance: Tom Eyres

A review of 2018 trail maintenance and outline of 2019 trail schedule and projects

Looking forward to 2019:

1. Toonie Rides
 - Toonie Rides April through July 20, 2019
 - Fall weekend Toonie Rides
 - See Sean and Damian to sponsor toonie ride
2. Trail Days
 - Posted on okcycling .com
 - First one at April 6, at Ellison
 - Monday night trail builds every 2nd Monday
3. Trail work:
 - Continue working with BC Parks/RSTBC for flow tail from Paligap to Rotten Cabin, Rotten Cabin re-routes
 - New entrance for Hammered Cow, Claim Trail to May Way or the Hwy
 - Continuance of trails above Big Ed
 - Predator, work with them for new green loop
 - Continued trail maintenance, paid trail brushing of grassland trails
 - Continued work with NORD for Ranchlands Trail Network
 - Section 57 crown land application for extension of Ellison trail network

Review of Events for 2019:

1. 3rd Annual Bike Fest May 2nd to 5th: David Boutillier
 - Movie Night (Beautiful Idiot and Revenance)
 - Ratio Bike Party
 - Rail Trail Art Ride
 - Good Old Fashioned Bike Race
 - Demo Day "Festival Style"
2. 1st Annual Liv Bombshell Enduro race – June 22nd
3. Trail Holistics Seminar with Mark Wood May 31-June 2
4. Sprockids – sign up Olympia

5. Trail Ninjas – sign up at okcycling.com
6. Iride Cycling BC – Elementary school program
7. High School Program – race series and practice

Shout out for volunteers for:

- Membership drive/management
- Group rides – sign in, flaggers, sweepers, bbq, etc
- Sponsors
- Trail day leaders
- Project leaders
- Help with website, finance, legal, fundraising, grant writing

Review of Financial Statement: Stacey Banks

Elections:

President: Dan Poulin resigning - vacant
Vice President: Matt Ball (leaving the country in June)
Treasurer: Stacey Banks resigning - vacant
Secretary: Nicole Guerrero
Mark Dowhaniuk – Trail Planning/Building
David Boutillier – Youth Director
Tom Eyres – Trail Director
Rosemary Whelpdale – Communications
Deans Franks and Mel Edwards – Events Directors
Demian Carson and Sean Simpson – Toonie Rides
Peter Dorey – at large

Vacant positions: president, treasurer, memberships, sponsors/grants, IT support

New Nominations:

Brett Woods: President
Pete Zabloutny: Treasurer

Notice of members resigning from the board Dan Poulin and Stacey Banks.
Thanks shared by the board for their involvement.
Thank you to Matt Ball and family, who are leaving the country in July.

Motion to approve list of Directors

Motion approved- Unanimous vote

Meeting adjourned at 9:30 pm

October 30, 2019

Debra Law, Chief Financial Officer and
Director of Financial Services
City of Vernon
3400 31st Street
Vernon BC V1T 5E6

**Re: North Valley Gymnastics Society (NVGS) –
Council Discretionary Grant Application – Fall 2019**

Thank you for your consideration of the enclosed Application.

Please Find enclosed the following documents:

1. Council Discretionary Grant Application
2. Minutes NVGS AGM February 26th, 2019
3. AGM Package including latest Financials Aug 31st, 2018 (Year-end Aug 2019 Financials to be released by Nov 30th, 2019)
4. List of members of the Executive
5. Community Support (construction gifts in Kind) Supporters thru Grants and Donations.
6. List of Equipment needs
7. Certificate of Incorporation – Copy
8. Corporate Case Statement – Updated Oct 2019

Special Note:

We recognize this is the second Grant request this calendar year, and have discussed this with Councilor Gares, and requested the committee waive the 'one per year' requirement.

Sincerely,



Paul Jeffry Williamson

Director

North Valley Gymnastic Society

NORTH VALLEY GYMNASTICS SOCIETY

4700 31st Street Vernon BC V1T 5J9 info@nvgym.com 250.558.5136 www.nvgym.com



The Corporation of the City of Vernon COUNCIL DISCRETIONARY GRANT APPLICATION FORM

IMPORTANT: The deadline for Council Discretionary Grant Applications are semi-annual being April 30 and October 31 each calendar year.

Applications will only be accepted during the intake periods of April 1 - April 30 and October 1 to October 31. Applications must be submitted to the Director of Financial Services no later than 4:00pm on the application deadline (April 30th and October 31st), if City Hall is closed that day, on the next working day that City Hall is open.

Applicants may run the risk of grant funding being depleted if waiting to apply until the October intake deadline.

If grant applications are received after the cut off periods they will be returned to the applicant and must be submitted at the next intake period.

Please note: Incomplete applications will not be considered

ORGANIZATION INFORMATION

NAME OF ORGANIZATION APPLYING FOR COUNCIL DISCRETIONARY GRANT:	North Valley Gymnastics Society # S-30490
CONTACT PERSON:	Paul Jeffry Williamson
ORGANIZATION MAILING ADDRESS:	4700 31st Street Vernon V1T 5J9
BUSINESS PHONE:	250-558-5136
EMAIL ADDRESS:	info@nvgym.com
REGISTERED NON PROFIT SOCIETY INCORPORATION NUMBER (required):	

"Personal information contained on this form is collected under the Freedom of Information and Protection of Privacy Act and will be used only for the purposes of responding to your request".

**City Hall Address: 3400 30th Street, Vernon BC, V1T 5E6
Inquiries: 250-545-1361
Web: www.vernon.ca**



The Corporation of the City of Vernon COUNCIL DISCRETIONARY GRANT APPLICATION FORM

ORGANIZATION GOALS, OBJECTIVES AND ACTIVITIES:

North Valley Gymnastics Society ("NVGS") is dedicated to promoting the health and physical fitness of the community. Permanent equipment and trained coaches provide a range of fitness options. Through careful programming, NVGS provides programs uniquely designed to make each participant feel welcome and comfortable without regard to ability or fitness level.

SERVICE PROVIDED TO THE COMMUNITY:

We provide the sport of Artistic Gymnastics for the lowest possible enrollment cost in organized programs by certified coaches, making it an attractive, safe and affordable activity for families with young children and all members of the community.

Regular participation in gymnastics by children helps develop their mental focus, balance, coordination, upper body strength, flexibility, speed, and endurance. Children can begin gymnastics as early as pre-school ages and progress through defined competency levels until age 18. Over 600 members visit NVGS each week to access our gymnastics programs as well as participate in our Drop-In programs which cater to all ages including adults. (Registration stats for Fall 2019 are: 563 for Recreational, 58 for Competitive, Total 621)

A PROFILE AND HISTORY OF THE ORGANIZATION AND ITS ACCOMPLISHMENTS:

Artistic Gymnastics in Vernon began in 1978, with programs offered by the Boys and Girls Club. On May 10, 1993 NVGS was founded and took over the programs offered by the Boys and Girls Club. For twelve years (1992-2004) programs were based at Beirsto Elementary School and club membership peaked at 225 members per session. Due to reduced gymnasium availability in 2005 NVGS was without a permanent facility. We moved between available spaces (the Vernon Recreation Centre and Armstrong Elementary School) until the Spring of 2012 when NVGS moved to its former location on 45 Avenue. Here membership rose to an average of 450 members per session. After completing significant renovations to meet the needs of NVGS the club moved to its current 31 Street location and with the additional space membership has risen to over 600 gymnasts per session.

PLEASE IDENTIFY THE STEPS YOUR ORGANIZATION HAS TAKEN TO ACQUIRE GRANTS FROM OTHER SOURCES:

Please see attached List of Contributors and successful Grant applications since our project began in June of 2017. (Special Thanks to Kal Rotary for \$20,000 towards our sprung floor)

We have received an 2019 'operations' grant from BC Gaming of Approx. \$31,500.

We currently have another Grant Application into BC Gaming specifically targeted for Gym Equipment. This grant is scheduled to be announced after October 31st 2019.

We have also applied to the following other organizations but not been successful;

Federated Co-op - Community Spaces, 55 + BC Games, Funtastic Sports Society, Municipality of Coldstream, Abby Dental, All Seasons RV, Black and McDonald, Jack and Betty Peters, Peters Tirecraft, Vernon Toyota, Steele Foundation, Vernon Home Builders Center.

City Hall Address: 3400 30th Street, Vernon BC, V1T 5E6

Inquiries: 250-545-1361

Web: www.vernon.ca



The Corporation of the City of Vernon

COUNCIL DISCRETIONARY GRANT APPLICATION FORM

GRANT REQUEST

(You may wish to provide attachments, please note below where these items can be found.)

AMOUNT OF REQUEST:

\$24,938.00. We recognize and respect the fact that funds are limited and other very deserving groups are shoulder to shoulder in line with us. We will gratefully accept any amount that the committee can allocate to us.

IN-KIND SERVICES: (please describe and include cost)

See attached list of contributors of in-kind services to our building project.

PURPOSE OF GRANT AND PROPOSED ALLOCATION OF FUNDS:

We respectfully request assistance in the purchase/replacement of the attached Gym Equipment list. Our list is long as we have been unable to address our equipment needs due to the building of our new facility. We have reduced our request to \$24,938 as our most urgent needs. This list will replace an aging balance beam, plus much needed pieces for general Gym use and augment our new foam pit. (Filling the foam pit, aka 'The Pit', was entirely financed by a fundraising effort of our membership)

BENEFITS TO COMMUNITY RESULTING FROM GRANT OR CITY GOALS AND OBJECTIVES THAT WILL BE MET, IF THE GRANT IS APPROVED:

Now that the construction of our new facility is almost complete, NVGS can focus on growth, gym equipment needs, and getting the club ready for hosting local and Provincial competitions. These events will bring athletes and families to Vernon, which is good for tourism and our economy.

These Grant monies will help us upgrade some essential gym equipment. As the Club grows over the coming 5 to 10 years, our goal is to move up to a full 14,000 sq ft facility as part of the Greater Vernon Master Recreation Plan.

DEGREE OF COMMUNITY FINANCIAL SUPPORT OR SPONSORSHIP:

See attached list of community Grants.
Not included on this list is the support of BC Gaming in the form of an operational grant.

City Hall Address: 3400 30th Street, Vernon BC, V1T 5E6
Inquiries: 250-545-1361
Web: www.vernon.ca



The Corporation of the City of Vernon COUNCIL DISCRETIONARY GRANT APPLICATION FORM

DEGREE OF DEMONSTRATED ECONOMIC DEVELOPMENT, ENVIRONMENTAL STEWARDSHIP OR SOCIAL BENEFIT THAT MAY BE GENERATED BY THE AWARD OF A COUNCIL DISCRETIONARY GRANT:

NVGS currently employees 11 part time coaches and one full time manager. We provide our youth with the opportunity to participate in the accredited sport of Artistic Gymnastics, as is offered in comparable communities across Canada. NVGS engages our youth by providing a supportive environment for meaningful youth participation in directing and designing physical activity opportunities, ensuring their own needs are met in a way that is motivating, socially stimulating, and enjoyable. Participation in gymnastics transforms the after-school hours from screen time to active time. Artistic Gymnastics is a 'Base' sport providing skills used in all sports.

GRANT QUALIFICATION CHECKLIST (please check all that apply):

- Community Based
- Providing a service which is not provided by any other group or organization within the City or which is provided for in another municipality and used by residents
- * Must only submit one application per calendar year
- Grant request is not to cover retroactive funding or to cover a deficit

Note: Organizations do not qualify for the discretionary grant program if they are in receipt of regional funding or are receiving grants or other assistance from the City of Vernon.

GRANT REQUIREMENTS (please attach to your grant application):

- Most Recent Set of Financial Statements
- Minutes of Most Recent Annual General Meeting
- List of Members of the Executive (including positions held, address and contact numbers)

In the case of newly formed groups, a budget and information regarding the organization purpose including list of Board of Directors will be sufficient.

Oct 30th, 2019

Date

Signature

* SEE COVER LETTER.

City Hall Address: 3400 30th Street, Vernon BC, V1T 5E6
Inquiries: 250-545-1361
Web: www.vernon.ca

NORTH VALLEY GYMNASTICS SOCIETY
ANNUAL GENERAL MEETING
Tuesday, February 26th @ 6:00 pm
4700 #31st Street
Vernon, BC V1T 5J9

1. Meeting Called to Order at **6:07pm** on **Tuesday, February 26th, 2019** by President, *Robin Nanji*

2. **Introduction of Directors and Attendance:**
Melissa Locke, Robin Nanji, Jenny Sibilleau, Paul Williamson, Garry Mugridge
Directors unable to attend: *Tigger Calvert, Rob Eggert*

3. Approval of Agenda for NVGS 2019 AGM

4. Adoption of Minutes from NVGS 2018 AGM (held on Feb. 5th, 2018)

5. President's Report (see AGM package 2019)

6. Treasurer's Report (see AGM package 2019)
*Motion to adopt 2018 Treasure's Report by Jenny Sibilleau, seconded by Robin Nanji. **MSC.**

7. Head Coach's Report (see AGM package 2019)

8. Facility Report and Slideshow

9. Acceptance of Members

10. Call for Nominations of Directors
 1. **Emily Phair** – nominated by Melissa Locke, seconded by Jenny Sibilleau
 2. **Jenny Sibilleau** – nominated by Melissa Locke, seconded by Robin Nanji
 3. **Paul Williamson** – nominated by Robin Nanji, seconded by Jeny Sibilleau
 4. **Robin Nanji**- nominated by Jenny Sibilleau, seconded by Melissa Locke
 5. **Garry Mugridge**- nominated by Robin Nanji, seconded by Jenny Sibilleau
 6. **Melissa Locke**- nominated by Jenny Sibilleau, seconded by Robin Nanji

7. **Melissa Hackman**- nominated by Garry Mugridge, seconded by Melissa Locke

11. Motion for Nomination of Directors by Robin Nanji, seconded by Paul Williamson. **MSC**

Meeting adjourned at 6:50 pm; Next meeting March 4th, 6pm at NVGS



NORTH VALLEY GYMNASTICS SOCIETY

Annual General Meeting

February 26, 2019

(6:00 pm at the gym, 4700-31st street, Vernon, BC)

AGENDA

1. Call to order
2. Introduction of Directors
3. Approval of Agenda AGM 2019
4. Adoption of Minutes of AGM, Feb 5th 2018
5. President's Report
6. Treasurer's Report
7. Head Coach's Report
8. Facility Report
9. Acceptance of Members
10. Call for Nominations of Directors
11. Nomination of Directors
12. Adjournment

NORTH VALLEY GYMNASTICS SOCIETY

~~4700 - 31 St. Vernon BC V1T 5J9 info@nvgym.com 250.558.5136 www.nvgym.com~~

North Valley Gymnastics Society
Feb 26, 2019 AGM

President's Report

Well it certainly has been a busy year. After our last AGM in February 2018, we continued with our push to get the new facility finished and ready for move in. We were finally able to take possession and move in to our beautiful new facility at the end of May and I would like to thank all of the volunteers who came and helped with not only the move, but the cleaning, and all of the details that went into making this dream a reality.

Shortly after our move we were incredibly fortunate to be given a grant from the Kal Rotary which allowed us to purchase our first ever full sprung floor! We are so grateful for the support of the Kal Rotary and many others in our community who have donated time, materials, expertise and funding. Without them, our new facility wouldn't have been possible.

While the building has certainly taken up the majority of the Board's time and energy, we were also focussed on continuous fundraising efforts. The club participated in the "Foam Pit Fundraiser" which has now raised over \$20,000.00 to go towards filling our pit. Only a few thousand dollars are still needed and we will be able to purchase everything required to have the pit area fully operational. Donations to the "Foam Pit Fundraiser" are still welcome at any time and very much appreciated.

Our Board of Directors have appeared before the Vernon City Council, Coldstream Council, GVAC, and RDNO numerous times of the past year and have been lobbying to garner the financial support from these various groups. As of this time, we have received a donation of \$17,250.00 from area's B and C of RDNO and are incredibly grateful for the support from these districts. We hope the other districts will follow suit in recognizing how important NVGS is to our community.

Our last few months have been dedicated to securing our new mortgage, paying our vendors and ensuring the club has a solid future going forward. We are continuing to apply for grants and are always seeking new avenues of funding whether it be for the finish work on the new facility or for new equipment needed. As a non-profit society, fundraising and grant applications are a core part of giving our community the full gymnastics facility that it needs.

Finally, I would like to take a moment and thank my fellow Directors for what has proven to be a long, stressful but rewarding year. Your dedication to our club, to our new

gym, and to our community has been above and beyond what anyone could expect from a volunteer position, and we would not have had the successes we have had without you. My deepest thanks to all of you.

Sincerely,

Robin Nanji

Treasurer's Report

North Valley Gymnastics Society's ("NVGS") year-end financial statements ending August 31, 2018 were prepared on a Notice to Reader basis by Nashir Kassam Chartered Professional Accountants.

Fiscal 2018 was a pivotal year for NVGS. During Fiscal 2017, our Board of Directors made the decision to look for a building that we could call our own to build a first-class facility for our members. After many months of looking for the right building (not only did the square footage need to be right but the ceilings needed to be high enough) and with funds from years of saving we were finally able to purchase the building we are in now in July of 2017 for \$670,000. We immediately began renovations and moved from our old rented premises to our existing building at the end of May 2018.

The construction cost of the building, including the cost of purchasing the property, was approximately \$1.75 million which was paid for via a combination of financing and the gym's operating income.

In January of 2019 we secured a \$1.2 million mortgage from VantageOne Credit Union which was utilized to repay construction financing provided by Prospera Credit Union and a third-party lender, and to repay our construction trades, with the exception of \$100,000 lent to us by an anonymous source (with no repayment terms) and approximately \$23K owed to our construction contractor who has kindly allowed us to repay the debt out of operating profits.

During the construction period, we were paying monthly rent of \$5,203 plus construction financing costs of \$6,730 for a total of \$11,933. Our monthly mortgage payment is significantly lower at \$6,870/month which will allow us to have enough funds leftover to repay the remaining \$123K in debt.

Revenue earned from gymnastics programs dropped slightly (2% or \$7K) from \$335K in Fiscal 2017 to \$328K in Fiscal 2018 predominantly a result of the week-long gym closure we had when we moved from the old facility to the new facility. Expenses net of construction costs were \$306K generating total income from operations of \$29K, not including the additional \$57K in income generated from Donations and Fundraising Revenue. With the combination of our operating income and income from donations and fundraising we were able to meet our debt obligations during the year.

Our Fiscal 2019 budget has been prepared conservatively with very little change in revenue or expenses from Fiscal 2018, other than taking into consideration the \$17,250 we received from NORD September 2018 and the \$36,800 BC Gaming Grant we received October 2018. The construction of the building has been substantially completed with the exception of landscaping and curbing which will be completed once the snow melts. The estimated cost of completion is approximately \$19K which will be offset by the \$17,640 security deposit held with the City of Vernon when it is released upon the satisfactory completion of the landscaping and curbing. Not including building expenses of approximately \$19K we've estimated Income from Operations of \$104K, more than enough to meet our debt obligations for the year.

While Fiscal 2018 was a very hard year financially we are proud that we've been able to meet our obligations and build a first-class gym for our members. We look forward to what the next year will bring us.

"K" denotes thousands

**NORTH VALLEY GYMNASTICS SOCIETY
FINANCIAL STATEMENTS
(Unaudited)
AUGUST 31, 2018**

TABLE OF CONTENTS

Notice to Reader

Statement A **Statement of Operations and Changes in Net Assets -
For the Year Ended August 31, 2018**

Statement B **Statement of Net Assets -
For the Year Ended August 31, 2018**

Statement C **Statement of Financial Position - Ended August 31, 2018**

Notes to the Financial Statements



CHARTERED PROFESSIONAL ACCOUNTANTS

#17A -100 Kalamalka Lake Road
Vernon, B.C. V1T 9G1
Phone: (250) 549-2569
Fax: (250) 549-1587

SHELDON KASSAM, CPA, CGA •
• Denotes Professional Corporation

NOTICE TO READER

On the basis of information provided by management we have compiled the statement of financial position of North Valley Gymnastics Society as at August 31, 2018, and the statement of operations and changes in net assets for the year then ended.

We have not performed an audit or a review engagement in respect of these financial statements and, accordingly, we express no assurance thereon.

Readers are cautioned that these statements may not be appropriate for their purposes.

Nashir Kassam
Chartered Professional Accountants

Vernon, British Columbia
December 7, 2018

STATEMENT A

**NORTH VALLEY GYMNASTICS SOCIETY
STATEMENT OF OPERATIONS AND CHANGES IN NET ASSET
FOR THE YEAR ENDED AUGUST 31, 2018
(Unaudited - See Notice to Reader)**

	2018	2017
REVENUE		
Competitive Program	\$ 45,914	\$ 35,646
Donation and Fundraising Revenue	49,469	213,421
Interest Income	806	734
Membership Income	281,602	299,296
Other Income	<u>7,825</u>	<u>80,925</u>
	<u>385,616</u>	<u>630,022</u>
 DIRECT EXPENSES		
Coach and Staff Expense	1,660	1,573
Competitive Program	5,702	5,394
Registration Fees	25,485	15,682
Wages and Benefits	<u>172,689</u>	<u>172,935</u>
	<u>205,536</u>	<u>195,584</u>
	<u>180,080</u>	<u>434,438</u>
 GENERAL OPERATING EXPENSES		
Advertising	194	2,084
Insurance	6,203	4,839
Interest and Bank Charges	51,999	14,981
Licences and Dues	120	80
Office and Miscellaneous	303	1,050
Professional Fees	20,854	9,953
Property Tax	7,660	4,296
Rent	49,654	62,434
Repairs and Maintenance	14,995	8,943
Supplies	1,255	954
Telephone	1,307	1,357
Utilities	<u>23,883</u>	<u>8,191</u>
	<u>178,427</u>	<u>119,162</u>
 INCOME FROM OPERATIONS	<u>\$ 1,653</u>	<u>\$ 315,276</u>

STATEMENT B

**NORTH VALLEY GYMNASTICS SOCIETY
STATEMENT OF NET ASSETS
FOR THE YEAR ENDED AUGUST 31, 2018
(Unaudited - See Notice to Reader)**

	2018	2017
OPENING BALANCE	\$ 525,257	\$ 209,981
REVENUE FROM OPERATIONS	<u>1,653</u>	<u>315,276</u>
CLOSING BALANCE - To Statement C	<u>\$ 526,910</u>	<u>\$ 525,257</u>

STATEMENT C

**NORTH VALLEY GYMNASTICS SOCIETY
STATEMENT OF FINANCIAL POSITION
AUGUST 31, 2018
(Unaudited - See Notice to Reader)**

	ASSETS	2018	2017
CURRENT ASSETS			
Cash		<u>\$ 49,441</u>	<u>\$ 162,529</u>
 CAPITAL ASSETS			
Building		1,748,060	771,167
Equipment		140,461	115,084
Office Equipment		3,769	3,653
Leasehold Improvements		<u>70,200</u>	<u>70,200</u>
		<u>1,962,490</u>	<u>960,105</u>
		<u>\$ 2,011,931</u>	<u>\$ 1,122,634</u>
LIABILITIES AND NET ASSETS			
CURRENT LIABILITIES			
Accounts Payable		\$ 314,213	\$ 37,069
Deferred Revenue (Note 1)		<u>89,171</u>	<u>61,664</u>
		<u>403,384</u>	<u>98,733</u>
 LONG TERM LIABILITIES			
Loan Payable		100,000	
Mortgages Payable (Note 2)		<u>981,637</u>	<u>498,644</u>
		<u>1,081,637</u>	<u>498,466</u>
 NET ASSETS			
Net Assets		<u>526,910</u>	<u>525,257</u>
		<u>\$ 2,011,931</u>	<u>\$ 1,122,634</u>



**NORTH VALLEY GYMNASTICS SOCIETY
NOTES TO THE FINANCIAL STATEMENTS
FOR THE YEAR ENDED AUGUST 31, 2018
(Unaudited - See Notice to Reader)**

NOTE 1 – DEFERRED REVENUE

Deferred revenue represents unspent resources externally restricted for specific use and restricted operating funding received in the current period that is related to the subsequent period.

	2018	2017
Deferred membership revenue	<u>\$ 89,171</u>	<u>\$ 61,664</u>

NOTE 2 – LONG TERM LIABILITIES

	2018	2017
The Prospera Credit Union Mortgage #1 is payable in monthly installments of \$3,020 including interest at 3.95% per annum.	\$ 481,637	\$ 498,644
The Prospera Credit Union Mortgage #2 is payable in interest only payments at prime plus 2.05% per annum.	250,000	
The Gervan Holdings Ltd. Mortgage is payable in interest only payments at 12% per annum.	<u>250,000</u>	<u> </u>
	<u>\$ 981,637</u>	<u>\$ 498,644</u>

**NORTH VALLEY GYMNASTICS SOCIETY
PROPOSED BUDGET F2019***

REVENUE

Competitive Program	49,872
Donation and Fundraising Revenue	11,130
Membership Income	338,967
Other Income	54,050

454,019

DIRECT EXPENSES

Coach and Staff Expense	2,863
Competitive Program	5,991
Registration Fees	17,537
Wages and Benefits	195,620

222,011

GENERAL OPERATING EXPENSES

Advertising	1,931
Insurance	6,203
Interest and Bank Charges	68,841
Licenses and Dues	-
Office and Miscellaneous	359
Professional Fees	11,350
Property Tax	8,000
Repairs and Maintenance	22,047
Supplies	614
Telephone	1,115
Utilities	7,941

128,401

INCOME FROM OPERATIONS **\$ 103,607**

***Actual Figures to 31Dec2018**

2019 NVGS AGM

Head Coach Report : Submitted by Kathy Stevens

The 2017-2018 year was another very successful year for NVGS. We employed 15 coaches (11 recreational and 4 competitive). We had two instructors take their NCCP training; one for Level 1 Gymnastics Foundations and the other Level 2 Intro to Competition. As is typical of any gymnastics club we lost three of our Recreational instructors in the fall of 2018 as they are off to Universities elsewhere. We have recruited two more gymnasts within our programs to start coaching, with another one doing apprentice hours.

Since our move to the new facility in late May we are now able to add more groups in the gym at any given time. With the addition of another bar station, a larger beam area, plus a full floor we can accommodate 8 groups of 6 gymnasts at one time, 2 groups more than we could offer at the old gym.

Our daytime and user group programs included Pre-school classes including a Parent and Tot class, Pre-school drop in, home school program, Splatsin Elementary School gymnastics unit, the Kindale Adult Developmental Association as well as couple SD22 school field trips. After school programs and Saturday morning classes represented the bulk of our programs. This also included Wednesday night Teen and Adult Drop in and Friday Night Family Drop in.

Our competitive program had another successful year of competitions. Some of the JO (Junior Olympic) levels 3 to 7 girls competed in as many as 5 competitions from the Zone 2 Cobweb Meet in December and go to the Ogoogo Invitational in June. All these meets were within the province. Our Interclub girls (Advanced Recreational level) competed up to 3 meets during the spring starting in March and also finishing with the Ogoogo Invitational.

This past year we offered single day spring break camps which turned out to be more popular than the week-long camps of previous years. We will continue to offer these in the future. A nine week Summer Session and week long summer camps rounded out our record enrolment year. We look forward to our first full year in our new facility.



October 2019

**Community Support for Construction of the
New North Valley Gymnastics Facility at
4700 31st Street**

1. Bourcet Engineering Structural	\$10,000
2. Wilf Lunde Architect 250-558-7792	\$ 3,000
3. Peart Engineering –Mechanical Consulting	\$ 1,000
4. SJ Pasechnik & Sons General Contractors	
a. 5% Mark up on Material/Suppliers Est Savings	\$20,000
b. Equipment Donation	\$10,000
5. Air Tech Mechanical	\$ 20,000
6. Hamilton Electrical Contracting & Randy Osborne	\$ 20,000
7. Castanet Media - Web Site coverage and \$100 prize money	\$ 1,000
8. Beach Radio	Airtime
9. The Tile Guy	\$ 17,000
10. Tip-it Waste Removal	\$ 500
11. Westridge Quarries Gravel Supplies	\$ 4,000
12. Nor-Val rentals	\$ 5,000
13. Laing Roofing/Firestone Roof Material	\$ 3,000
14. Boyds Distributors	\$ 1,000
15. Rona Building Supplies	\$ 1,300
16. Lakeview Door	\$500
17. Torbram Electrical Suppliers	\$ 1,000
18. A & B Damp Proofing	\$450
19. Sunshine Autographics	\$500
20. Tekmar Control Systems/Sun Touch	\$400
21. M&K Ready Mix	\$ 1,200
22. Elices's Printopia	\$ 200
23. A-1 Machine On site welding – Railing and Ring Anchors	\$ 500
24. Merton Excavating - Supplied Large Packer for parking lot.	\$ 1,750
25. Grizzly Curbs	\$ 1,000
26. A & D Asphalt Solutions	\$ 1,000

Total to Date; \$ 125,300

NORTH VALLEY GYMNASTICS SOCIETY

4700 31st Street Vernon BC V1T 5J9 info@nvgym.com 250.558.5136 www.nvgym.com

NVGS Supporters thru Grants and Donations

1	Kal Rotary - Sprung Floor	20,000
2	RDNO Electoral Area B and C	17,250
3	Foord Foundation	10,000
4	Canadian National Christian Foundation	10,000
5	S & L Knuever Family Foundation	3,500
6	Kal Tire	2,000
7	Gibbs Family	1,000
8	Dr. Rex Hawthorne	1,000
9	Individuals less than \$100	2,150
	Total	\$66,900

Grants and donations total raised for the project to date:

\$192,200

(Not Including the Foam Pit)

'Fill the Foam Pit Campaign'

Funds Raised by the Gymnasts selling foam blocks for \$5 plus larger single donations direct to the foam pit costs.

Total Raised \$21,500

Summary:

- **The Old Vernon RV Building was purchased in June 2017 and occupancy was granted on May 31, 2018**
- **A HUGE THANKS to Hundreds of volunteer hours that have gone into this facility over and above the financial donations.**
- **Special Recognition goes to Garry Mugridge Volunteer Project Manager, Pete Pasechnik our General Contractor and our 'Angel' Lender (who wishes to remain anonymous) without whose support this project would not have been possible.**

North Valley Gym 4700 - 31st Street Vernon							
Gym Equipment list - October 2019							
Ranking	Type	Cost CDN	Cost USD	x 1.31 = CDN	Shipping & Brokerage Allowance	Approx Taxes	Totals
1	Balance Beam		3,214	4210	1,000	505	5715
2	Tumble Track		4,860	6366	1,300	764	8430
2	Spotting Blocks		5,845	7656	750	918	9,324
2	Spring Board	892			500	107	1499
Grant Request Total							\$24,968.00
Note: 3 pieces are ranked #2 due as they complement each other.							
Further equipment needs to be filled by fundraising efforts:							
3	Single Adjustable Bar	3,214			250	385	3,849
4	Wedge Mats		295	386	500	46	932
5	Vault Attachment		1,300	1703	750	204	2657
6	Air Floor		2,095	2744	500	329	3573
7	Air Package		2,720	3563	750	428	4741
8	Launch Pad		575	753	250	90	1093
	Total						\$16,845
All Txs at 12%							
Shipping is 'best guess'							

North Valley Gym – Equipment Illustrations

Balance Beam:

We have several Beams and need to start replacing them. The adjustment mechanisms are slowing wearing down making the beams harder and harder to adjust safely.
\$3,214 USD (Tumbl Trak ships from Michigan USA)



Tumble Track:

A Long trampoline to do any number of skills and play on. Jump, Run, Flip, you name it – It is all fun on a tumble trak! This will be a welcome addition to our Foam Pit!
\$4,860.USD (Ships from Michigan USA)



Spotting and Learning Blocks:

Spotting Blocks are an integral part of any gymnastics program. From jumping, hopping, tumbling over the blocks to Coaches using them for Spotting. Blocks get used over and over every day, and ours are showing their wear with close to 600 kids using them 5 or 6 days a week! \$5,845 USD (Ships from Michigan USA)



Springboards:

Our Fleet of Springboards have been around a long time and it is time to start upgrading them! \$892 (Spieth Anderson Ships from Quebec)



NUMBER: S-30490



SOCIETY ACT

CANADA
PROVINCE OF BRITISH COLUMBIA

CERTIFICATE OF INCORPORATION

I Hereby Certify that

NORTH VALLEY GYMNASTICS SOCIETY

has this day been incorporated under the *Society Act*

*Issued under my hand at Victoria, British Columbia
on May 10, 1993*

A handwritten signature in cursive script that reads "J. Powell".

JOHN S. POWELL
Registrar of Companies

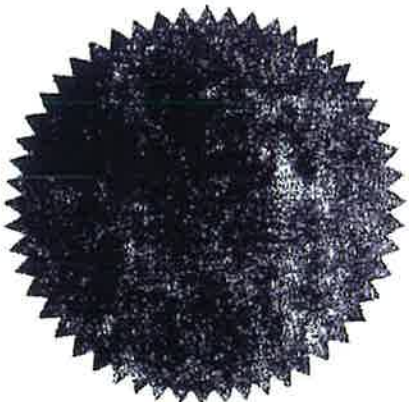



Province of
British Columbia

Ministry of
Finance and
Corporate Relations

Corporate, Central and Mobile
Home Registry
940 Blanshard Street
Victoria
British Columbia
V8W 3E6

File Number: S-30490

NORTH VALLEY GYMNASTICS SOCIETY

I hereby certify that the documents attached hereto are copies of documents filed with the Registrar of Companies on May 10, 1993

JOHN S. POWELL
Registrar of Companies



October 28, 2019

North Valley Gymnastics Society

Corporate Case Statement

The North Valley Gymnastics Society (NVGS) has been in operation as a non-profit society since May 10th, 1993. Since its inception a core group of dedicated coaches along with many volunteers have offered the children and youth of our community an accredited Artistic gymnastics program. The expansion of the club to a larger facility is allowing us to offer more comprehensive programs to the entire community and we are pleased that our membership grew by over 100 gymnasts for our Fall 2018 Session. The current club membership sits at over 600 and draws students from Lumby, Armstrong and Enderby. Find us on Facebook and on the Web at <https://www.nvgym.com>

OUR NEW GYM:

- An 8,500 sq. ft. facility that includes:
 - Main Gym, 6,400 sq. ft, 40 x 40 Sprung Floor and Foam Safety Pit.
 - Mini Gym 700 sq. ft.
 - Entrance/Viewing 1,450 sq. ft. including Foyer, Office, Washrooms, Viewing area and Coaches room.

1. NEED:

- a. Facility: We moved into our new Gym at 4700 31st Street on May 31st 2018
- b. Financial: Vantage One has granted us a \$1.2 million mortgage with a current building assessment at \$1.6 million.
- c. Equipment: We maintain annual fundraising programs to support our gym. We are always monitoring our equipment for safety and wear. We can provide a current list of needs upon request.
- d. User Groups and Programming: The Club serves over 600 students per week in recreational, competitive, interclub and drop in programs. Other user groups include: Kindale Development Assn. and SD 22. There is room for growth with these and other groups.
- e. Community: The support of North Okanagan residents has proven the demand for Artistic gymnastics. Our construction gifts in kind total over \$120,000, and total community grants to date are also over \$65,000.

2. CAPABILITY:

- a. The NVGS has a proven track record, operating for over 25 years in our community. We currently have a staff of 11 part time Coaches plus a full time Club Manager.
- b. Our coaches are NCCP certified through Gym BC and regularly attend courses.
- c. Kathy Stevens the Founder and Naomi Rokus our Club Manager along with our coaching staff are passionate about gymnastics and very committed to our club.
- d. They have operated in many facilities over the years. The most challenging was Beirsto School Gym where a full set up and take down was a daily routine!

Page 1 of 2

3. BENEFITS:

- a. Artistic Gymnastics is an integral part of many communities in Canada, and youth sports in general are essential to help our youth develop into strong and confident members of society.
- b. With this new facility, we look forward to growing our programs and expanding our offering to existing and new user groups. Since opening the new gym, membership grew by 100 gymnasts for fall registration and it is common to have a waitlist of up to 100 for some programs.
- c. Our Foam Pit is up and running providing a safe and fun place to learn and practice new skills.

4. CONSEQUENCES AND RISKS:

- a. By taking on a large mortgage the club will be committed to significant monthly payments, and we will continue to look for community support.
- b. The Gym equipment is monitored closely for safety and potential failures.
- c. We face substantial future risks:
 - i. The increase in the minimum wage challenges us to keep up to fair wages and rising costs of the programs.
 - ii. Building maintenance is now being considered in our budgets and savings.
 - iii. Recruitment and training of new coaches is an ongoing task.

5. THE GOAL:

- a. To continue to offer quality programming on safe and challenging gym equipment in a fun, friendly and respectful atmosphere.
- b. To acquire a full 14,000 sq. ft facility in the coming years in partnership with Greater Vernon Recreation.

The North Valley Gymnastics Club has been helping build a healthy and active community for over 25 years by offering an important sport and recreational activity to the residents and children of Greater Vernon.

If you are looking for more information, please contact me to set up a meeting.

Sincerely,



Paul Jeffry Williamson

pjwmson007@gmail.com

Corporate Fundraising

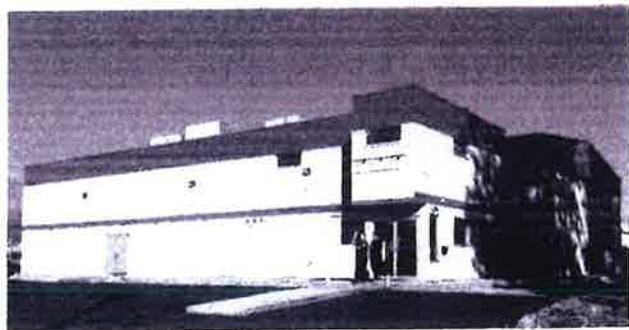

The Corporation of the City of Vernon
COUNCIL DISCRETIONARY GRANT



OKANAGAN ASSOCIATION OF CLASSICAL MUSIC ENTHUSIASTS (OACME)

APPLICATION

- A. Application form (with attached local community partners planned contributions)**
- B. Financial statements – most recent**
- C. The minutes of the most recent AGM**
- D. The lists of the BoD and Executive**
- E. Registered Society documents**
- F. Supporting documents:**
 - a. Budget for the Vernon Proms 2020**
 - b. Editorial article about the festival in the national classical music magazine La Scena Musicale, Summer Issue 2019**
 - c. Recent local press**
 - d. Case for financial support**
 - e. Photo Report – Vernon Proms 2019**
 - f. Past programs**

Our website: www.vernonproms.ca



The Corporation of the City of Vernon COUNCIL DISCRETIONARY GRANT APPLICATION FORM

IMPORTANT: *The deadline for Council Discretionary Grant Applications are semi-annual being April 30 and October 31 each calendar year.*

Applications will only be accepted during the intake periods of April 1 - April 30 and October 1 to October 31. Applications must be submitted to the Director of Financial Services no later than 4:00pm on the application deadline (April 30th and October 31st), if City Hall is closed that day, on the next working day that City Hall is open.

Applicants may run the risk of grant funding being depleted if waiting to apply until the October intake deadline.

If grant applications are received after the cut off periods they will be returned to the applicant and must be submitted at the next intake period.

Please note: Incomplete applications will not be considered

ORGANIZATION INFORMATION

NAME OF ORGANIZATION APPLYING FOR COUNCIL DISCRETIONARY GRANT:	Okanagan Association of Classical Music Enthusiasts
CONTACT PERSON:	Natalia Polchenko
ORGANIZATION MAILING ADDRESS:	[REDACTED]
BUSINESS PHONE:	[REDACTED]
EMAIL ADDRESS:	[REDACTED]
REGISTERED NON PROFIT SOCIETY INCORPORATION NUMBER (required):	S0067709

"Personal information contained on this form is collected under the *Freedom of Information and Protection of Privacy Act* and will be used only for the purposes of responding to your request".

City Hall Address: 3400 30th Street, Vernon BC, V1T 5E6
Inquiries: 250-545-1361
Web: www.vernon.ca



The Corporation of the City of Vernon

COUNCIL DISCRETIONARY GRANT APPLICATION FORM

ORGANIZATION GOALS, OBJECTIVES AND ACTIVITIES:

OUR GOALS:

1. To fill the gap that exists in the region when all local classical music organizations are on hiatus from early June until October and classical music performers and audiences have no outlet for playing or experiencing this type of music.
2. To make access to high quality musical programming affordable for everybody by producing/ presenting performances in public places.
3. To attract more people of all ages to become involved in musical amateurism by providing educational and performing opportunities for amateur musicians of all abilities.

OUR OBJECTIVES and ACTIVITIES:

1. In accordance to Greater Vernon Cultural Plan, to enhance a positive quality of life for Vernon residents and to increase the cultural capacity of the community by staging a first-class annual, multi-week classical music festival.
2. To make Vernon a destination for classical music tourism.

SERVICE PROVIDED TO THE COMMUNITY:

(1) Annual multi-weeks Vernon Proms Classical Music Festival that includes performances by local, provincial, national and international artists. Programming includes high quality chamber music concerts, workshops, opera, a youth Summer Arts camp, and outdoor concerts. Because one of the Festival's goals is to be affordable and accessible to all, about half of the events are free to the public.

(2) Another OACME project is Early Music Okanagan (EMO). Early music is comprised of a broad musical era that includes Medieval, Renaissance and Baroque periods. Our program incorporates professional and amateur musicians who enjoy sharing their love of early music with our community. EMO produces a series of early music concerts played on period instruments.

A PROFILE AND HISTORY OF THE ORGANIZATION AND ITS ACCOMPLISHMENTS:

The Okanagan Association of Classic Music Enthusiasts (OACME) was incorporated in 2017 by a core group of people dedicated to bringing the annual Vernon Proms Classical Music Festival to the community. The young festival quickly becomes Vernon's signature Summer event. In July 2016 the first Proms debuted with five events - three concerts and two workshops over two weeks. By the next year, the festival had grown to include six concerts and three workshops.

Then, when our grass-roots efforts were supported by a RDNO grant, the festival exploded into a month-long celebration of classical music. The Proms'18 had 25 events that attracted local and international artists, while our audiences included music lovers not only from Vernon, but also from Kelowna, Kamloops, Vancouver, and Victoria.

This year was our fourth year and the festival keeps growing by leaps and bounds. We were thrilled to receive provincial funding - from Creative BC and BC Arts Council - for the first time, in addition to the RDNO's grant. Thanks to this funding, we scheduled even more events for this season - concerts, opera, workshops, and masterclasses. Many were free for the public. We had world-class musicians and ensembles performing. Telus filmed a full-length documentary about our opera production. We enjoy recognition from the national classical music media.

PLEASE IDENTIFY THE STEPS YOUR ORGANIZATION HAS TAKEN TO ACQUIRE GRANTS FROM OTHER SOURCES:

For the Proms 2020 we have applied for (1) a Local Festivals grant from Canadian Heritage and for (2) a grant from SOCAN for commissioning music from a local composer; have received (3) an Early Career Development grant from BC Arts Council that will employ a young professional for a year; we are in a process of applying for project grants for Community Arts Festivals from (4) Creative BC and from (5) Arts Council BC.

In 2017 and 2018 we applied for and received project grants from RDNO, but are not eligible to apply for the third year. For the last festival, we received a co-op funding from Vernon Tourism for assistance with our marketing campaign.

City Hall Address: 3400 30th Street, Vernon BC, V1T 5E6

Inquiries: 250-545-1361

Web: www.vernon.ca



The Corporation of the City of Vernon

COUNCIL DISCRETIONARY GRANT APPLICATION FORM

GRANT REQUEST

(You may wish to provide attachments, please note below where these items can be found.)

<p><u>AMOUNT OF REQUEST:</u></p> <p>\$6,000</p>
<p><u>IN-KIND SERVICES: (please describe and include cost)</u></p> <p>In-kind contributions by the OACME and the organizing team of the Vernon Prom Classical Music Festival include volunteer labour contribution (2,286 volunteer hours in 2019 @ \$20/hour = \$45,720). Waived artistic fees, office expenses, and production costs involved in production of the festival for the last festival had in-kind value of \$43,102.</p> <p>We expect to keep in-kind contribution by the organizing team at the similar level for the next festival as well, in-kind-value \$89,000.</p>
<p><u>PURPOSE OF GRANT AND PROPOSED ALLOCATION OF FUNDS:</u></p> <p>(1) Grant -> for the Project - 5th Annual Vernon Proms Classical Music Festival in July 2020. (2) The grant will help to provide free concerts and workshops for the community as a part of Vernon Proms'2020 - at least 10 free events to be attended by 1500+ audience. The grant will cover the rental fees for the venues, production costs, and fees for professional artists. (2) We would be able to maintain very affordable prices for our ticketed concerts at the Proms'2020. (3) Getting the grant from City of Vernon for the Proms 2020 will allow us to sustain and to grow the festival further, and will support the festival until 2021, when we will become eligible for an operating grant from the province.</p>
<p><u>BENEFITS TO COMMUNITY RESULTING FROM GRANT OR CITY GOALS AND OBJECTIVES THAT WILL BE MET, IF THE GRANT IS APPROVED:</u></p> <p>During 4-months long Summer Break taken by all local classical music organizations we will provide:</p> <p>(1) A month-long access to high quality classical music concerts and workshops that enhance quality of life of Vernonites and increase the community's cultural capacity, in accordance with the Greater Vernon Cultural Plan. (2) Affordable access. About half of our events are free, and the ticketed ones are very affordable. (3) Performing and learning opportunities for local amateur musicians and music students. (4) Paid work for local musicians. (5) Attraction for classical music tourists.</p>
<p><u>DEGREE OF COMMUNITY FINANCIAL SUPPORT OR SPONSORSHIP:</u></p> <p>We enjoyed in-kind support and collaborations with many local community partners for our past festivals. See attached list of planned contributions by local community partners for the Proms 2020, in-kind value of \$69,090.</p>



The Corporation of the City of Vernon

COUNCIL DISCRETIONARY GRANT APPLICATION FORM

DEGREE OF DEMONSTRATED ECONOMIC DEVELOPMENT, ENVIRONMENTAL STEWARDSHIP OR SOCIAL BENEFIT THAT MAY BE GENERATED BY THE AWARD OF A COUNCIL DISCRETIONARY GRANT:

In 2019 season \$60,819.79, or 62% of the Proms' budget were spent locally. Economic investment and tourism spend into our local Vernon economy in 2019 was:

Local hotels for artists \$ 6,994.31	Catering, food from local businesses \$ 937.11
Local media advertising \$1,800	Local venues' rental \$7,582.04
Local production expenses \$2,405	Local professionals' fees \$356.17
Local Box office fees \$4,008.94	Local artists and music contractors fees \$36,736.22
Total \$ 60,819.79	

We expect that with a larger budget for the year 2020 (63% growth), the economic investment and tourism spend into our local Vernon economy will grow accordingly, to at least \$99,134.

Social benefit: 10 free concerts were attended by 1200 spectators in 2019. We plan for 1500 in 2020.

GRANT QUALIFICATION CHECKLIST (please check all that apply):

- Community Based
- Providing a service which is not provided by any other group or organization within the City or which is provided for in another municipality and used by residents
- Must only submit one application per calendar year
- Grant request is not to cover retroactive funding or to cover a deficit

Note: Organizations do not qualify for the discretionary grant program if they are in receipt of regional funding or are receiving grants or other assistance from the City of Vernon.

GRANT REQUIREMENTS (please attach to your grant application):

- Most Recent Set of Financial Statements
- Minutes of Most Recent Annual General Meeting
- List of Members of the Executive (including positions held, address and contact numbers)

In the case of newly formed groups, a budget and information regarding the organization purpose including list of Board of Directors will be sufficient.

Oct 30th, 2019

Date

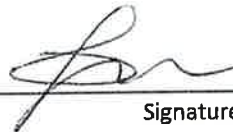

Signature

Planned contributions by local community partners

Partners	Contribution	In-kind value
Volunteers	2286 hrs @ \$20/hour	\$45,720
Vernon Community Music School	Workshop and rehearsal venue 5 days @200/day	\$1,000
Vernon Community Arts Centre	Summer camp Room rental 10 days @120/day	\$1,200
Vertigo Art Gallery	Workshop and rehearsal venue 5 days @200/day	\$1,000
Mackie Lake House	Event venue rental 1 day @150/day	\$150
Friesen's Countrytyme Garden restaurant and bakery	Event catering 2 events @300/event	\$600
Sparkling Hill Resort	2-night Package x 2 persons gift certificate for door prize	\$1,020
North Okanagan Community Concert Association	Promotion and advertisement in seasons' programs	\$500
Okanagan Symphony Orchestra	Promotion and advertisement in seasons' programs	\$500
Greater Vernon Museum and Archives	Promotion and special exhibition	\$500
Local musicians and ensembles	Performing fees waved	\$16,800
Kawakubo Sushi Restaurant	2 gift certificates @\$50	\$100
Total		\$69,090

Okanagan Association of Classical Music Enthusiasts

Financial Statements

August 31, 2019

(Unaudited - see Notice to Reader)

Sladen *SM* Moore
Chartered Professional Accountants



CPA CHARTERED
PROFESSIONAL
ACCOUNTANTS

Members of
Chartered Professional Accountants of British Columbia

Sladen *SM* Moore

Chartered Professional Accountants

Partners and Principals:

Stephen Cousins, CPA, CA, BComm *
Lynette Freisinger, CPA, CA, BSc *
Courtney Satchell, CPA, CA, BBA *

3005 - 35 Avenue
Vernon, BC V1T 2S9
Telephone: 250-545-0754
Fax: 250-545-8689
E-mail: info@sladenmoore.com

Notice to Reader

On the basis of information provided by management, we have compiled the balance sheet of Okanagan Association of Classical Music Enthusiasts as at August 31, 2019 and the statement of operations and surplus for the year then ended.

We have not performed an audit or a review engagement in respect of these financial statements and, accordingly, we express no assurance thereon.

Readers are cautioned that these statements may not be appropriate for their purposes.

Sladen Moore

Vernon, B. C.
September 10, 2019

Chartered Professional Accountants



CPA CHARTERED
PROFESSIONAL
ACCOUNTANTS

Members of
Chartered Professional Accountants of British Columbia

* Providing professional services through a corporation

Okanagan Association of Classical Music Enthusiasts

Balance Sheet August 31, 2019 with comparative figures for 2018 (Unaudited - see Notice to Reader)

	<u>2019</u> \$	<u>2018</u> \$
Assets		
Current		
Cash	12,482	180
Accounts receivable	<u>5,171</u>	<u>-</u>
	<u><u>17,653</u></u>	<u><u>180</u></u>
Liabilities		
Current		
Accounts payable and accruals	3,547	-
Due to related parties	<u>14,000</u>	<u>-</u>
	17,547	-
Members' equity		
Surplus	<u>106</u>	180
	<u><u>17,653</u></u>	<u><u>180</u></u>

Okanagan Association of Classical Music Enthusiasts

Statement of Operations and Surplus Year ended August 31, 2019 with comparative figures for 2018 (Unaudited - see Notice to Reader)

	<u>2019</u> \$	<u>2018</u> \$
Receipts		
Tickets	38,194	11,562
Grants	29,685	9,000
Donations	18,501	7,024
Expense reimbursements	4,357	-
Workshop fees	2,055	1,902
Merchandise	171	150
	<u>92,963</u>	<u>29,638</u>
Disbursements		
Performers	58,987	19,603
Marketing	10,069	3,454
Venue rental	7,582	2,345
Travel	7,160	104
Box office charges	4,009	-
Production costs	2,405	893
Insurance	1,088	500
Professional fees	356	-
Membership fees	328	131
Bank charges	316	285
Merchandise	301	607
Training	267	-
Office and sundry	169	1,079
Donations	-	457
	<u>93,037</u>	<u>29,458</u>
Excess (deficiency) of receipts over disbursements	(74)	180
Surplus, beginning of year	<u>180</u>	<u>-</u>
Surplus, end of year	<u><u>106</u></u>	<u><u>180</u></u>

Okanagan Association of Classical Music Enthusiasts

Notes to Financial Statements

August 31, 2019

(Unaudited - see Notice to Reader)

1. Basis of presentation

The preparation and presentation of these financial statements may not conform to Canadian generally accepted accounting principles and therefore may not be appropriate for all readers' purposes.

MINUTES of the **Annual General Meeting** of
OACME (Okanagan Association of Classical Music Enthusiasts)
Held 6pm on August 29th 2019 at Bamboo Fusion Restaurant

ATTENDEES: Natalia Polchenko (President); Janet Trufyn (Treasurer); Sally Bassett (Secretary);
Members of the Public: Mabel Thibault (Vernon Proms Volunteer Co-ordinator); Karen Neufeld.
Regrets: Allison Kooyman (Vice-President) due to illness. Quorum present;

PREVIOUS AGM MINUTES:

These were read and approved.

AGENDA: As written in the by-laws

PRESIDENT'S REPORT:

Natalia gave a verbal report.

Vernon Proms 2019 is now over. It was bigger than 2018, with more events and a larger budget. The production of the Opera ('Marie Chapdelaine') was a big part of the Proms financial budget and time. Natalia is working on another grant application which will have some more details and can be sent to board members when completed in the next few days.

FINANCIAL REPORT: a preliminary financial report was presented by Janet and Natalia who worked together on this. It was discussed at length. They have used a different computer program than last year. This one is more in line with the formats used by accounting firms. The total budget was much more than last year. An official Financial Report will soon be available from our accounting firm and will be sent to board members then.

OLD BUSINESS:

Grants: waiting for the decision on our application for 'Federal Grant for Community Festivals'. Result expected in September.

Vernon Proms 2019 review:

The new publicity items (tent, banners etc) were discussed and deemed worth the expense.

The draw was very popular. People who gave their email addresses will be contacted by email but they can unsubscribe at any time. People who gave only their phone numbers will not be contacted.

The locations used were discussed.

There was much discussion of the various Vernon Proms concerts and workshops held this year.

The opera was well received.

Admission to concerts with professional musicians was by paid tickets. These musicians were paid at union rates.

For concerts with non-professional musicians the admission was by donation. These performers were given 100% of the donations at the door. This was discussed. Natalia said that the grants are to cover the expenses of putting on these concerts.

There was higher attendance at the 'concerts by donation' than at the ticketed concerts. It was mentioned that a group in Vancouver find a connection between scheduling on weekends and lower attendance rates. This was discussed.

There was a waitlist for the youth camps.

The oboe/bassoon workshop was not held due to lack of participants.

As Volunteer Co-ordinator for the Vernon Proms 2019, Mabel presented a report on the various concerts (see attached), including suggested modifications in the jobs done by the volunteers and for general improvement of 'front of house' next year. This report was approved. Sally and Mabel presented a report on the Vernon Proms 2020 in general (see attached). This year Natalia was unable to meet with them as initially planned. Each point in this report was discussed and addressed during the meeting.

NOMINATIONS AND ELECTIONS OF OFFICERS:

All current board members are willing to stand in current positions – pending definitive confirmation with Allison. There were no nominations from the floor.

By acclamation the current Board Members will continue in the same positions as before – with the position of Vice-President depending on Allison's reply. (Update September 2nd – Allison will stand again as Vice-President).

NEW BUSINESS:

Grants:

Natalia is in the process of a grant application to Creative BC.

Natalia plans to apply for a Summer Student Grant for 2020.

Other grants will be applied for, to cover events in 2020. More details on this at next meeting.

Event Plans for 2020:

January 2020

Natalia has been in discussions with a Quebec musician who is planning to do a tour in BC in January 2020. He plays piano and harpsichord in concerts and workshops. We may be able to link into his tour.

Vernon Proms 2020: Plan to run less than 25 days, probably from the last week of June until about 20th

August. The idea of forming a small committee to prepare for Vernon Proms 2020 was suggested and discussed, but no motion or decision made. There will not be an opera production in 2020. Natalia mentioned some of the musicians with whom she has been discussing possible future performances at Vernon Proms. Some of these musicians have performed in previous VP events and some have not.

NEXT MEETING: will be in September – date and time to be announced later.

MEETING ADJOURNED: by 9.30pm



2019 BC SOCIETY ANNUAL REPORT

BC Society • Societies Act

NAME OF SOCIETY: OKANAGAN ASSOCIATION OF CLASSICAL MUSIC ENTHUSIASTS

Incorporation Number: S0067709
Business Number: 70720 3097 BC0001
Filed Date and Time: October 1, 2019 03:28 PM Pacific Time
Annual General Meeting (AGM) Date: August 29, 2019

REGISTERED OFFICE ADDRESS INFORMATION

Delivery Address: Mailing Address:

[Redacted address information]

DIRECTOR INFORMATION AS OF August 29, 2019

Last Name, First Name Middle Name:

[Redacted director name]

Last Name, First Name Middle Name:

KOOIJMAN, ALLISON [Redacted]

Delivery Address:

[Redacted address]

Last Name, First Name Middle Name:

POLCHENKO, NATALIA [Redacted]

Delivery Address:

[Redacted address]

Last Name, First Name Middle Name:

TRUFYN, JANET [Redacted]

Delivery Address:

[Redacted address]

CERTIFICATION

I, Lisa Findlay, certify that I have relevant knowledge of the society, and that I am authorized to



Number: S0067709

Societies Act
CERTIFICATE OF INCORPORATION

OKANAGAN ASSOCIATION OF CLASSICAL MUSIC ENTHUSIASTS

I Hereby Certify that ~

OKANAGAN ASSOCIATION OF CLASSICAL MUSIC ENTHUSIASTS was incorporated under the *Societies Act* on June 28, 2017 at 03:00 PM Pacific Time.



*Issued under my hand at
Victoria, British Columbia*

A handwritten signature in black ink, appearing to read "Carol Prest".

CAROL PREST

REGISTRAR OF COMPANIES
PROVINCE OF BRITISH COLUMBIA
CANADA



CONSTITUTION

BC Society - Societies Act

CERTIFIED COPY
Of a document filed with the
Province of British Columbia
Registrar of Companies

CAROL PREST

NAME OF SOCIETY: **OKANAGAN ASSOCIATION OF CLASSICAL MUSIC ENTHUSIASTS**

Incorporation Number: S0067709
Business Number: 70720 3097 BC0001
Filed Date and Time: June 28, 2017 03:00 PM Pacific Time

The name of the Society is OKANAGAN ASSOCIATION OF CLASSICAL MUSIC ENTHUSIASTS

The purposes of the Society are:

- a.) to popularize classical music in the community and involve more people, including children, in musical amateurism through organizing and producing classical music events; educational workshops, seminars, and masterclasses; opera productions, concerts, and festivals;
- b.) to support amateur classical musicians and groups, as well as professional musicians, specializing in early music and opera by providing educational and performance opportunities;
- c.) to operate as a non-profit organization and to seek out and receive governmental and charitable donations towards such objectives and purposes;
- d.) to apply for all lawful and necessary grants in aid;
- e.) to hypothecate, borrow on, pledge or mortgage the assets of the Society for the purposes of raising funds to support the purposes of the Society; and
- f.) to do all acts necessary or incidental to the foregoing.

Budget for Vernon Proms '2020

Planned Expenses

For further information regarding eligible and ineligible expenses, please consult the [Application Guidelines](#).

Applicant Name (required)
Okanagan Association of Classical Music Enthusiasts

Planned Expenses ¹	Final Expenses of your Previous Festival Cash Only ²	Planned Expenses of your Current Festival Cash Only ²	Funding Requested ³
1. Volunteer support			
Training and Coordination	\$267	\$300	\$300
Food and non-alcoholic beverages		\$150	\$150
Transportation and parking			
Distinctive clothing		\$300	\$300
Recognition		\$150	\$150
Other - ineligible expenses (please specify below)			
Subtotal	\$267	\$900	\$900
2. Local artists, artisans, cultural carriers, and heritage performers			
Fees, expenses, and transportation	\$34,237	\$50,000	\$40,000
Copyrights, SOCAN fees, or other licensing fees		\$1,500	\$1,500
Other - ineligible expenses (please specify below)			
Production costs	\$2,405	\$2,500	
Subtotal	\$36,642	\$54,000	\$41,500
3. Non-Local artists, artisans, cultural carriers, and heritage performers			
Fees, expenses, and transportation costs	\$24,750	\$25,000	
Copyrights, SOCAN fees, or other licensing fees		\$1,500	
Artists accommodation and travel	\$7,160	\$4,000	
Subtotal	\$31,910	\$30,500	
4. Event/Venues			
Non-capital expenses related to temporary venues (e.g., rental stages, tents, risers, traffic barriers)			
Venue rental (e.g., interpretive/performance spaces, heritage villages, etc.)	\$7,582	\$8,000	\$5,000
Exhibitions (e.g., shipping, framing, installation, dismantling)			
Rental of technical equipment (e.g. sound, lighting, electrical, etc.)		\$400	\$400
Sanitation expenses (e.g. portable toilet rentals, garbage removal, service or rentals)			
Security, first aid, and ambulance services			
Other - ineligible expenses (please specify below)			
Subtotal	\$7,582	\$8,400	\$5,400

Planned Expenses ¹	Final Expenses of your Previous Festival Cash Only ²	Planned Expenses of your Current Festival Cash Only ²	Funding Requested ³
5. Promotion			
Local community promotion (social media, advertising, translation ⁴ , website updates, etc.)	\$8,479	\$15,000	\$11,000
Non-local community promotion (social media, advertising, translation ⁴ , website updates, etc.)	\$1,590	\$2,000	
Other - ineligible expenses (please specify below)			
Merchandise	\$301	\$400	
Subtotal	\$10,370	\$17,400	\$11,000
6. Project Administration			
Temporary event contractors		\$3,500	\$3,500
Salaries		\$23,000	
Operating costs	\$1,169	\$2,000	
Liability insurance ⁵	\$1,088	\$3,000	\$3,000
Other - ineligible expenses (please specify below)			
Box office charges	\$4,009	\$4,500	
Subtotal	\$6,266	\$36,000	\$6,500
Total funding requested from the Local Festivals Component ⁶			\$65,300
Grand Total Expenses ⁷	\$93,037	\$147,200	

Anticipated Revenue

Note: Your budget must balance (no surplus or deficit).

Applicant Name (required)
Okanagan Association of Classical Music Enthusiasts

Anticipated Revenue ^a	Final Revenue of your Previous Festival Cash Only ²	Anticipated Revenue of your Current Festival Cash Only ²
1. Earned Revenue		
Ticket sales	\$38,194	\$40,000
Merchandising and other sales	\$171	\$300
Kiosk rentals		
Other (please specify below)	\$2,055	\$2,100
Workshop tuition	\$4,357	
Travel expense reimbursements	\$5,064	\$5,500
Donations		
Subtotal	\$49,841	\$47,900
2. Applicant's Contribution (please specify below)		
Artistic Director's personal contribution	\$12,437	0
Subtotal	\$12,437	\$0
3. Local support Community Partners⁹		
Total cash support from all your local partners (e.g., non-government, community-based groups, businesses, individuals, clubs)	\$1,000	\$1,000
4. Government support¹⁰		
Federal support (please specify below)	0	\$65,300
BCAH LOCAL FESTIVALS Component		
Provincial or territorial support (please specify below)		
Creative BC	\$20,685	\$22,000
BC Arts Council	\$4,000	\$5,000
Municipal administration or equivalent authority support (please specify below)		
North Okanagan Regional District Project Grant	\$5,000	
City of Vernon Discretionary Grant		\$6,000
Subtotal	\$29,685	\$98,300
5. Non-Local Support Community Partners		
Other community support other than local (not including municipal, provincial and federal)		
Grand Total Anticipated Revenue	\$92,963	\$147,200

Is there a difference between the expenses of the previous edition and those of the current year's budget? (required)

Yes No

Please explain

Higher performers fees - to increase the number of locally produced concerts and number of pro musicians and artists involved.
Higher marketing expenses to develop and grow local audiences. Higher insurance and SOCAN fees.
Paid temp event contractors and salaried admin. to avoid volunteers' burnout due to rapid growth of the festival.



The Corporation of the City of Vernon COUNCIL DISCRETIONARY GRANT APPLICATION FORM

IMPORTANT: *The deadline for Council Discretionary Grant Applications are semi-annual being April 30 and October 31 each calendar year.*

Applications will only be accepted during the intake periods of April 1 - April 30 and October 1 to October 31. Applications must be submitted to the Director of Financial Services no later than 4:00pm on the application deadline (April 30th and October 31st), if City Hall is closed that day, on the next working day that City Hall is open.

Applicants may run the risk of grant funding being depleted if waiting to apply until the October intake deadline.

If grant applications are received after the cut off periods they will be returned to the applicant and must be submitted at the next intake period.

Please note: Incomplete applications will not be considered

ORGANIZATION INFORMATION

NAME OF ORGANIZATION

APPLYING FOR COUNCIL DISCRETIONARY GRANT: Okanagan Landing and District Community Association (OKLDCA) www.okanaganlanding.com

OKANAGAN LANDING & DISTRICT

Community Association

CONTACT PERSON: Charlene Karvonen and Kathleen Nolan

ORGANIZATION MAILING ADDRESS: 7813 Okanagan Landing Road, Vernon, BC V1H 1H2, Canada

BUSINESS PHONE 250-542-2500

EMAIL ADDRESS: info@okanaganlanding.com

REGISTERED NON PROFIT SOCIETY

INCORPORATION NUMBER (required): Incorporation S0003546 Business Number 11906 6116 BC001

"Personal information contained on this form is collected under the *Freedom of Information and Protection of Privacy Act* and will be used only for the purposes of responding to your request".

City Hall Address: 3400 30th Street, Vernon BC, V1T 5E6

Inquiries: 250-545-1361

Web: www.vernon.ca



The Corporation of the City of Vernon COUNCIL DISCRETIONARY GRANT APPLICATION FORM

ORGANIZATION GOALS, OBJECTIVES AND ACTIVITIES: To promote recreational, educational, and cultural activities in Okanagan Landing and District area; and to provide suitable buildings and grounds for the furtherance of such objectives.

The Okanagan Landing & District Community Association is a registered charitable organization committed to improving community activities for residents of Okanagan Landing and surrounding area. Paddlewheel Park and the facilities at Paddlewheel Park are for the benefit of and use by the public.

SERVICE PROVIDED TO THE COMMUNITY:

Museum- The Stationhouse Museum is operated by the Okanagan Landing & District Community Association, as a satellite of Greater Vernon Museum and Archives. It celebrates the history of the area and houses an amazing 21'x4' scale model depicting Okanagan Landing in 1914, when sternwheelers provided the only transportation from Vernon to Penticton. It is available for private tours and open to public during the summer Thursday through Sundays 12:00 to 4:00 pm. This free admission venue is operated entirely by volunteer organizer and tour guides. (Donations appreciated). Positive feed back is overwhelming and improved signage would help the volunteers because currently most people visiting the park are not even aware the museum is there.

Paddlewheel Park- The park and beach are owned by the Okanagan Landing & District Community Association and maintained by the City of Vernon for the benefit of the public. The beach is family friendly and (Association and City) amenities include children's playpark, picnic pavilion, sandy beach with a full disabled access, plenty of grass and shade trees, basketball, tennis, and beach-volleyball courts, boat-launch, public washrooms and plenty of parking. It is enjoyed by thousands of locals and tourists every year. A real treasure to the community.

Paddlewheel Hall- Our unique and beautiful venue on Okanagan Lake is home to the monthly Coffee House (featuring local artists and musicians), Paddlewheel Park Drop In Bridge Club, FUN Club (ladies group), Drop In Yoga, Community Garage Sales, Craft Fairs and many other community association hosted events. Our hall is also available to rent for special occasions large or small such as weddings, anniversaries, birthdays, family reunions, corporate events and celebrations of life at Paddlewheel Hall.

North Okanagan Sailing Association (NOSA)- Leases buildings and lake front access property to operate a non-profit society dedicated to the promotion of small boat, dinghy and catamaran sailing offering family and individual memberships, Youth and Adult sailing lessons, and regular Thursday night racing for members and enrolled sailing students. NOSA is a valuable local program that will benefit from public exposure and increased tourism.

City Hall Address: 3400 30th Street, Vernon BC, V1T 5E6

Inquiries: 250-545-1361 Web:

www.vernon.ca



The Corporation of the City of Vernon COUNCIL DISCRETIONARY GRANT APPLICATION FORM

A PROFILE AND HISTORY OF THE ORGANIZATION AND ITS ACCOMPLISHMENTS:

The Okanagan Landing and District Community Association has been serving the community since 1949.

On April 8th, 1949, the Okanagan Landing and District Community Association came into being under the Societies Act. Since that time **the Association's Board of Directors and Members volunteer thousands of hours every year of their time and skills adding value to the community and City of Vernon by preserving the heritage site and history.**

Over 100 years ago, the area known as Paddlewheel Park was the site of CPR shipbuilding and a bustling centre of commerce. It was here that the sternwheel steamships Aberdeen, Okanagan, Sicamous, and the tugboat Naramata were constructed.

Before the rise of the automobile, journey by ship was the fastest and easiest way to travel in the Okanagan. The lake boats would have carried everything needed for daily life and commerce. Ships were the only reliable and efficient way for mail, people and cargo to travel. The Station House was the primary facility to board the Sternwheelers.

When the railroad withdrew its services in 1936, the Station House passed into private hands. In 1982 it was donated to the Okanagan Landing & District Community Association by Wes and Kay Whitehead. The heritage building now serves our community as a museum and repository for historical memorabilia, an amazing 21' x 4' scale model depicting Okanagan Landing in 1914 when sternwheelers provided the only transportation from Vernon to Penticton and photos from our past.

PLEASE IDENTIFY THE STEPS YOUR ORGANIZATION HAS TAKEN TO ACQUIRE GRANTS FROM OTHER SOURCES:

In 2018 Okanagan Landing and District Community Association applied for and received three grants.

1. Community Foundation of North Okanagan- \$8000 to match OKLDCA funds and paint the hall.
2. BC Hydro Grass Roots- \$2000 to change lighting to LED.
3. 55+ Grant – to procure an AED.

We respectfully submit this request to the City of Vernon to achieve a goal to increase awareness and emphasize our cultural heritage.

GRANT REQUEST

(You may wish to provide attachments, please note below where these items can be found.)

City Hall Address: 3400 30th Street, Vernon BC, V1T 5E6

Inquiries: 250-545-1361 Web:

www.vernon.ca



The Corporation of the City of Vernon COUNCIL DISCRETIONARY GRANT APPLICATION FORM

AMOUNT OF REQUEST:

The total amount for sign improvement is \$7383 (quote is itemized below so that some or all the projects may be funded.) The Okanagan Landing and District Community Association can contribute up to 30% of the funds required for the total project reducing our request to **\$4000**.

Priority 1

\$ 1630 – Paddlewheel Hall Roadside Bulletin Sign to post events (cost is to refurbish, repair and update the functionality to magnetic letters that may be changed using a pole rather than a ladder)

*This bulletin style sign allows us to advertise events. Unfortunately, due to its age, **the current function and accessibility is a serious safety concern**. Our senior volunteers currently climb a ladder to install the letters and the tracks need repair.*

Priority 2

\$ 2760 – Historical Wall Murals to emphasize cultural heritage (with picture & social media opportunities.)
\$ 827 – **Station House Museum Signs**- 3 signs are needed to attract visitors (one on each side of the facility).

*This free admission venue is operated entirely by volunteer organizer and tour guides. (Donations appreciated). Positive feed back of tours is overwhelming. **Improved signage would help the volunteers because currently most people visiting the park are not even aware the museum is there. They graciously approach visitors to verbally welcome them for a tour.***

Priority 3

\$ 1600 – Paddlewheel Hall Pergola Sign to increase awareness, emphasize heritage (with picture & social media op.)
\$ 566 – Paddlewheel Hall road and lakeside signs.

\$ 7383

The OKLDCA Budget is currently managing enough funds to create a reserve for the overall hall maintenance and upkeep. We need to ensure we can maintain the HVAC (now needing repair or replacement), update the kitchen and the deck in the next 5-year long term plan. As such it is of great importance for us to secure the funds for improved signage through this grant application.

IN-KIND SERVICES: (please describe and include cost)

The Association is willing to consider joint ventures with the City of Vernon on promotional projects or opportunities aligned with the improved signage to benefit community and tourism.

Volunteers will be provided as required for labor and marketing projects to minimize costs and assist in the success of the project.

The Association will provide 30% of the cost.

City Hall Address: 3400 30th Street, Vernon BC, V1T 5E6

Inquiries: 250-545-1361 Web:

www.vernon.ca



The Corporation of the City of Vernon

COUNCIL DISCRETIONARY GRANT APPLICATION FORM

PURPOSE OF GRANT AND PROPOSED ALLOCATION OF FUNDS:

Okanagan Landing and District Community Association (OKLDCA) wants to collaborate with the City of Vernon to **promote our cultural heritage**. Our Park Aesthetics committee recognizes the value of heritage parks and museums for tourism and cultural awareness. We want to increase awareness using signs and other marketing tools to benefit tourism and contribute to cultural our cultural heritage.

Cultural heritage is the legacy of physical artifacts and intangible attributes of a group or society that is inherited from past generations. Cultural heritage includes tangible culture (such as buildings, monuments, landscapes, books, works of art, and artifacts), intangible culture (such as folklore, traditions, language, and knowledge), and natural heritage (including culturally significant landscapes, and biodiversity).

OKLDCA formed committees to address Paddlewheel Park improvements. Kathleen Nolan took leadership of these groups to address concerns including but not limited to overall aesthetics and functional issues. The City of Vernon agreed to provide picnic tables for the Pavilion and an updated park sign consistent with other city park signs.

To improve awareness and aesthetics our committee toured various city and private venues to look at signage and other features. OKLDCA is also developing a Park Improvement Plan in collaboration with the City of Vernon and aligning the 2020-2024 contract between the two parties.

The goals include visually emphasizing the Station House Museum and Paddlewheel Hall using murals and heritage compatible signs. The concept and priorities are to attract attention to the importance of the venue from Okanagan Landing Road and the lake side traffic.

BENEFITS TO COMMUNITY RESULTING FROM GRANT OR CITY GOALS AND OBJECTIVES THAT WILL BE MET, IF THE GRANT IS APPROVED:

Okanagan Landing and District Community Association is looking forward to promoting the City of Vernon and the Association via improved marketing. The Park Committee recognizes the value of heritage parks and wishes to increase awareness using signs and other marketing for the benefit of the entire Vernon community and tourism of our city.

DEGREE OF COMMUNITY FINANCIAL SUPPORT OR SPONSORSHIP:

Approximately \$2500 in funds and another estimated \$2500 (or 180 hours at minimum wage) in volunteer hours on the committees and projects related to this initiative.

DEGREE OF DEMONSTRATED ECONOMIC DEVELOPMENT, ENVIRONMENTAL STEWARDSHIP OR SOCIAL BENEFIT THAT MAY BE GENERATED BY THE AWARD OF A COUNCIL DISCRETIONARY GRANT:

City Hall Address: 3400 30th Street, Vernon BC, V1T 5E6
Inquiries: 250-545-1361 Web:
www.vernon.ca



The Corporation of the City of Vernon COUNCIL DISCRETIONARY GRANT APPLICATION FORM

Currently the City of Vernon does not track the number of visitors to the park and boat launch. The number of visitors to the museum averages 500 (300 adults and 200 youth) annually and donations are approximately \$400 annually. We believe that moving in this direction will allow us to improve Paddlewheel Park and Station House event opportunities to work on educating the public about environmental issues regarding the park and the lake. This is a first step in organizing and hosting environmental awareness campaigns in the park for the public.

GRANT QUALIFICATION CHECKLIST (please check all that apply):

- ✓ Community Based
- ✓ Providing a service which is not provided by any other group or organization within the City or which is provided for in another municipality and used by residents
- ✓ Must only submit one application per calendar year
- ✓ Grant request is not to cover retroactive funding or to cover a deficit

Note: Organizations do not qualify for the discretionary grant program if they are in receipt of regional funding or are receiving grants or other assistance from the City of Vernon.

GRANT REQUIREMENTS (please attach to your grant application):

- Most Recent Set of Financial Statements
- Minutes of Most Recent Annual General Meeting
- List of Members of the Executive (including positions held, address and contact numbers)
- Attached Visual Package of Signs

Last Name	First Name	Address	Postcode	Phone	Email
Albrecht	Leslie				
Heinrichs	Clif & Terri				
Bainbridge	Diana & Darrel Voaklander				
Dickson	Carolyn				
Karvonen	Charlene				
Nolan	Kathleen				
Schier	Verne				

Oct 23, 2019
Date

Charlene Karvonen
Signature
C. Karvonen

Date

Signature
K. Nolan

City Hall Address: 3400 30th Street, Vernon BC, V1T 5E6
Inquiries: 250-545-1361 Web:
www.vernon.ca



**Okanagan Landing & District
COMMUNITY ASSOCIATION**

Servicing the Community
Since 1949

7813 Okanagan Landing Road Vernon BC V1H 1H2

Web: www.okanaganlanding.com

Email: info@okanaganlanding.com

September 3, 2019
Members
Board of Directors
OL&DCA

Treasurer's Report

Highlights for up to August 31, 2019

Bookings – As of August 31, 2019, the hall bookings (not including cleaning, SOCAN or insurance costs) are:

	<u>August 2019</u>	<u>August 2018</u>	<u>August 2017</u>
Current Year Bookings	\$51,700	\$55,915	\$43,005
Next Fiscal Year Bookings	\$26,480	\$25,340	\$25,720
Future Fiscal Year Bookings	\$1,320	\$6,600	\$0

Financial Reporting

- Year to date (August 2019), there is a net gain of \$21,217 compared to a net gain of \$34,750 last year. Two of the main reasons the net income was higher last year was due to the \$10,000 received in Grants last year and the \$5200 spent this year on website development
- The Association has \$17,008 in a short-term account.
- The Association has \$14,120 in the Capital Projects Account.
- There are currently 50 bookings for this fiscal year and last year there were 60 booked at this time.

Current Year's Revenue

- Hall Rental Revenue is down (\$4215) over the same period last year.
- Membership fees are down (\$300) over last year.
- Special events revenue is up (\$1680) over last year.

Current Year's Expenditure

- Total Hall expenditures are up (\$1315) over the same period last year. I have broken out the Website development into its own expense account to better track just the actual telephone/internet expenses. Hall maintenance is down quite a bit over last year offsetting the website development cost this year.
- There is \$4500 in Hall Security Deposits for upcoming events. There is \$29,080 in hall rental deposits, \$1350 in hall cleaning deposits, \$1040 in event insurance deposits and 857.48 in SOCAN deposits.

Station House Restoration

- Balance in Station House account as at August 31, 2019 – \$5,893.34

Respectfully,

Karol Hansma, Bookkeeper

NOTES:

The Landing had \$60,389.03 in the chequing account as of August 31, 2019. Of that amount, \$4500 is being held in Security Deposits, \$29,080 in hall deposits, \$1350 in Event Insurance deposits, \$857.48 in SOCAN deposits and \$1040 in Cleaning deposits for upcoming events booked at the Hall. This leaves a cash flow of about \$23,562 in the chequing account as of the end of August 2019. There is also \$17,008 in a term account and \$14,120 in a Capital projects account.

Regards,
Karol Hansma



Okanagan Landing & District Community Association Balance Sheet As at 31/08/2019

ASSET

Current Assets		
Credit Union Equity	36.50	
Chequing Bank Account	60,389.03	
Term Account	17,008.17	
Capital Projects Account	14,120.70	
Building Account	5,893.34	
Prepaid General Business Insur...	5,922.00	
Prepaid Director's Liability	450.00	
Total Cash		103,819.74
Total Current Assets		<u>103,819.74</u>
Capital Assets		
Land		978,000.00
Buildings		838,600.00
Building Renovations		223,588.11
Furniture and Equipment		35,794.16
Current Year Purchases		3,972.56
Current Year Renovations		41,660.80
Total Capital Assets		<u>2,121,615.63</u>
TOTAL ASSET		<u><u>2,225,435.37</u></u>

LIABILITY

Prepaid Liabilities		
Accounts Payable		4.74
Hall Security Deposits		4,500.00
Hall Deposits		29,080.00
Hall Cleaning Deposits		1,350.00
Event Insurance Deposits		1,040.00
SOCAN Deposits		857.48
Total Prepaid Liabilities		<u>36,832.22</u>
Current Liabilities		
GST/HST Paid on Purchases	-486.81	
GST/HST Owing (Refund)		-486.81
Total Current Liabilities		<u>-486.81</u>
TOTAL LIABILITY		<u>36,345.41</u>

EQUITY

Retained Earnings		
Invested in Capital Assets		2,075,381.00
Retained Earnings - Previous Year		92,491.94
Current Earnings		21,217.02
Total Retained Earnings		<u>2,189,089.96</u>
TOTAL EQUITY		<u>2,189,089.96</u>
LIABILITIES AND EQUITY		<u><u>2,225,435.37</u></u>

**Okanagan Landing & District Community Association
Comparative Income Statement**

31-Aug-19 CONFIDENTIAL

	Current Month		2018/19 Year to Date		2018/19 Budget-10 months		18/19 Yr to Date Comparison to 17/18	
	Revenue	Expenditure	Revenue	Expenditure	Revenue	Expenditure	Revenue	Expenditure
REVENUE								
Hall Revenue								
Hall Rental	9,120.00		51,700.00		50,416.67		55,915.00	
Hall Cleaning	750.00		6,150.00		7,975.00		7,590.00	
Event Insurance	800.00		4,420.00		5,886.67		5,650.00	
SOCAN	0.00		1,095.34		2,383.33		1,184.94	
Receipts for Damage	130.75		2,663.18		-		390.00	
Special Events	0.00		8,246.50		4,583.33		6,564.67	
Membership Fees	0.00		1,320.00		1,376.00		1,620.00	
NOSA Lease	0.00		1,331.00		1,191.67		1,331.00	
Other Income	-0.03		238.87		-		1,238.00	
Donations	0.00		910.00		458.33		11,459.90	
Bridge Group	0.00		2,000.00		-		1,700.00	
Interest	0.00		180.01		150.00		177.87	
Net Sales	10,800.72		80,254.90		74,400.00		94,821.38	
Station House Revenue								
Station House Donations	0.00		0.00		-		20.00	
Total SH Revenue	0.00		0.00		-		20.00	
TOTAL REVENUE	10,800.72		80,254.90		74,400.00		94,841.38	
EXPENSE								
Disbursements								
Hall Booking Agent	808.72		4,847.74		6,416.67		5,424.89	
Hall Cleaning	506.35		5,157.74		6,829.17		6,345.00	
Event Insurance	800.00		4,420.00		5,886.67		5,650.00	
SOCAN	0.00		1,080.10		2,383.33		1,239.30	
Hall Maintenance	84.67		7,190.03		7,333.33		11,801.78	
Cleaning Supplies	0.00		1,766.21		1,833.33		1,508.46	
Garbage	294.34		2,218.51		2,750.00		2,327.33	
Telephone	0.00		73.55		641.67		674.86	
Internet/Website/Telephone	122.53		1,711.99		1,375.00		1,355.58	
Website Devt	73.03		5,246.52		-		0.00	
Gas	42.43		2,907.56		2,201.67		2,193.30	
Hydro	0.00		1,604.36		2,281.67		1,611.00	
Water/Sewer	0.00		1,107.54		1,883.33		1,589.05	
Insurance	614.00		6,904.82		6,875.00		6,706.37	
Special Events	0.00		5,282.13		4,583.33		4,077.23	
Newsletter	0.00		0.00		183.33		0.00	
Advertising	0.00		101.27		275.00		154.25	
Banking Fees	0.00		55.00		91.67		92.50	
Admin/Office Expenses	42.87		2,686.27		1,833.33		2,094.41	
Bookkeeping	369.00		4,351.12		4,125.00		3,966.75	
Donation	0.00		0.00		916.67		600.00	
Professional Fees	0.00		0.00		-		615.00	
Total Disbursements	3,757.94		58,712.46		60,729.17		60,027.06	
Stn House Disbursements								
Stn House Special Events	0.00		0.00		-		0.00	
SH General Maintenance	0.00		90.00		-		0.00	
SH Office Expenses	43.80		235.42		-		84.60	
Total SH Disbursements	43.80		325.42		-		84.60	
TOTAL EXPENSE	3,801.74		59,037.88		60,729.17		60,091.66	
NET INCOME	6,998.98		21,217.02		13,670.83		34,749.72	
			20,307.02				23,289.82	
			Income without donations				Income without donations	

Okanagan Landing & District Community Association

AGENDA - November 5th, 2018 Minutes by Secretary Karvonen

Call to Order 1905h

Quorum (20 reached) 30 people attended

Motion to accept Agenda M/Errol Holm S/Cliff Heinrichs **Carried**

Motion to accept

Minutes of AGM - November 6, 2017 M/Dave Albrecht S/Cyril Karvonen **Carried**

Corrections 2017 AGM minutes – motion to review 2017/2018 financials – second Kelly Megyesi

President's Welcome and Report – Verne Schier

- We really appreciate the turn out and we put together an agenda that we hope will meet your expectations for this evening.
 - Thanks to the board members for their dedication to the meetings and following through with actions items and initiatives:
 - This board has adopted best practices for collaborating on these initiatives including investigating and voting on all activities
 - We have strong open communication with each other
 - We always seek multiple quotes from vendors to ensure due diligence when making expenditure decisions
 - We are improving our record keeping by organizing online and hard copy files as well as naming and dating our forms for version control
 - We have been successful this year in writing grants and receiving awards.
 - Thanks to all the volunteers- many of our members and board members contribute a lot of time to the activities, events and hall maintenance. I don't want to single out any individuals and would rather THANK EVERYONE:
 - Over 100 hours of service for hall maintenance and painting enabled us to be successful receiving \$8000 in grant funds from CFNO (Community Foundation of North Okanagan).
 - Also, thanks for help at our events including set up and take down.
 - Thanks to our hard-working personnel including our custodian, book keeper and booking agent. Without the services of these people it would be impossible to operate our hall successfully.
- Our hall rentals and overall financials are in good shape, so I will pass it over to Danny Gilmore to report.
- Recognition of three long time Board Members Eldie Jamleson, Murray Hainer (absent) and Errol Holm attended and accepted a card.

Financial Review 2017 – 2018 – Danny Gilmore reported

Following an 18-point checklist Victor Cummings and Danny Gilmore checked our financials thoroughly and verified all transactions. All signatures and deposits were in order. Recommendation to the board to investigate suitable GIC account for the large balances of funds.

Treasurer's Report – Karol Hansma / Leslie Albrecht

2017 – 2018 Financial Statements – description of the current hall rentals being very good along with increased revenue from the rental increases. The Board will dedicate additional funds to a reserve fund in order to address long term planning for the hall for such items as furnace, A/C, water heater, floors, roof etc.

Motion to forgo the appointment of an auditor M/Cliff Henrich S/Dave Albrecht Carried

Motion to approve the 2018 – 2019 Budget M/Ken Dickson S/Joanne Ludwig Carried

Reports

Membership reported by Carolyn Dickson- 134 members/11 Associate members Total Members 145 (up from 109 previous year) note: Associate members are people living outside of our catchment area and 25% of memberships can be associate members

Stationhouse Museum, Social Events, Bridge Club reported by Diana Bainbridge-see attached reports.

Business

Reported by Charlene Karvonen

1. The Board has developed and implemented:
 - a. Hall Maintenance Checklist (result -improved compliance from renters)
 - b. Improved Safety through:
 - i. Safety Inspections and Accident /Incident Forms
 - ii. Automated External Defibrillator (AED) has been installed (using an AED immediately after sudden cardiac arrest can increase the chance of survival by more than 90%. AED's are safe and will not work on an individual whom is not in cardiac arrest).
 - iii. First Aid Kit for members.
2. Hall Infrastructure Improvements:
 - a. Smart thermostats installed saving on energy bills
 - b. LED lighting implementation underway (BC Hydro Grant \$2000)
 - c. Paint and baffles to refresh the hall for prime-time rental season and enjoyment of all
 - d. Landscaping improvements complete and proceeding with park tables and benches.
 - e. Working on installation of a security system to address some incidents documented in 2018
3. Board is working on Marketing and Promotion: update website and promotional materials

Election of Board Members for 2018 – 2019

Board of Directors:

Leslie Albrecht

Diana Bainbridge

Carolyn Dickson

Cliff Heinrichs

Terri Heinrichs

Kathleen Nolan

Patricia Trail

Verne Schier

Darrel Voaklander

Open Discussion

Member requested that the Board investigate goose controls for the park and will provide some information on lights that deter geese.

Adjournment 1947h Motion to adjourn M/Terri Heinrichs S/Dave Albrecht Carried.

New Board convened for a brief meeting.

Motion to purchase three one hundred dollar gift cards for the resigning long term Directors.

M/Carolyn Dickson S/Leslie Albrecht Carried.

PRIORITY # 1



EXISTING SIGNS

→ Safety issue.

PRIORITY # 2



→ Promote Museum.



Priority #2



18th Avenue Landing CPR Station
Paddlewheel Hall and Lumber Company building
1900-1910



PADDLEWHEEL HALL AND MUSEUM

Washroom murals / photo op walls
to include vintage photos, BC green signs and photo info and
Paddlewheel logo

PRIORITY #3

wayside



PADDLEWHEEL HALL



WATER SIDE

Hanging signs and direct hand painted lettering on the building. This all would be to match the vintage photos attached. These are only suggested locations with more or less possible. It would be great to have one on the main hall outside. It was mentioned that weddings prefer no decorations but this sign could be made to be light weight and removeable.



The Corporation of the City of Vernon

COUNCIL DISCRETIONARY GRANT APPLICATION FORM



IMPORTANT: The deadline for Council Discretionary Grant Applications are semi-annual being April 30 and October 31 each calendar year.

Applications will only be accepted during the intake periods of April 1 - April 30 and October 1 to October 31. Applications must be submitted to the Director of Financial Services no later than 4:00pm on the application deadline (April 30th and October 31st), if City Hall is closed that day, on the next working day that City Hall is open.

Applicants may run the risk of grant funding being depleted if waiting to apply until the October intake deadline.

If grant applications are received after the cut off periods they will be returned to the applicant and must be submitted at the next intake period.

Please note: Incomplete applications will not be considered

ORGANIZATION INFORMATION

NAME OF ORGANIZATION APPLYING FOR COUNCIL DISCRETIONARY GRANT:	Schubert Centre Society
CONTACT PERSON:	Shirley Higgins; Interim General Manager Elaine Gallacher; Support
ORGANIZATION MAILING ADDRESS:	3505 30th Avenue Vernon, BC V1T 2E6
BUSINESS PHONE:	250 549 4201
EMAIL ADDRESS:	schubertcentre@shaw.ca
REGISTERED NON PROFIT SOCIETY INCORPORATION NUMBER (required):	

"Personal information contained on this form is collected under the *Freedom of Information and Protection of Privacy Act* and will be used only for the purposes of responding to your request".



The Corporation of the City of Vernon

COUNCIL DISCRETIONARY GRANT APPLICATION FORM

ORGANIZATION GOALS, OBJECTIVES AND ACTIVITIES:

Schubert Centre has been a social and recreational 'hotspot' for seniors since 1984. Our staff and volunteers diligently uphold the United Nations Principles for Older Persons resolution, which states that seniors have the right to dignity, care, independence, participation, and self-fulfillment in society. To this end, our mission is to strive to help seniors maintain a good quality of life by providing a variety of social and recreational programs and services which are based on the abilities and interests of our members.

SERVICE PROVIDED TO THE COMMUNITY:

Please refer to Appendix "A" - SERVICE PROVIDED TO THE COMMUNITY

A PROFILE AND HISTORY OF THE ORGANIZATION AND ITS ACCOMPLISHMENTS:

PROFILE AND HISTORY OF THE ORGANIZATION AND ITS ACCOMPLISHMENTS:

The Schubert Centre began in 1981 as a much-needed community centre for seniors. In 1984 the doors were opened at our current location and it has been a social and recreational hot spot for seniors ever since. Schubert Centre started with 360 founding members and has grown to over 900 members today. The Schubert Centre accomplishments include the development and sustainability of programs and services. As a result of the aging facility we are tasked with renovation projects to maintain the structure. Members and non-members alike enjoy the wide range of activities offered: bus tours, a café, exercise room and classes, dancing & dances, choir, shuffleboard, table tennis, floor curling, full service woodworking shop, crafts, dances, games & cards, adult day programs, catering services, meals on wheels program and much more.

Schubert Centre provides practical support for seniors; meals on wheels program. After hearing that Interior Health had stopped providing the program Schubert Centre restarted it, to continue providing community members with disabilities, convalescing or veterans with meals delivered to their homes.

PLEASE IDENTIFY THE STEPS YOUR ORGANIZATION HAS TAKEN TO ACQUIRE GRANTS FROM OTHER SOURCES:

Please refer to Appendix "B" OTHER SOURCES



The Corporation of the City of Vernon

COUNCIL DISCRETIONARY GRANT APPLICATION FORM

GRANT REQUEST

(You may wish to provide attachments, please note below where these items can be found.)

AMOUNT OF REQUEST:

\$5,000.00 toward the total cost of the replacing flooring & office furnishings project.

IN-KIND SERVICES: (please describe and include cost)

Schubert Centre offers programs and services to community members and our 1200 members daily from 8:00 AM to 4:00 PM. This would not be possible without the dedication of our volunteers who are involved in every aspect Schubert Centre. Volunteer activities include, but are not limited to: answering telephones, reception, connecting individuals to programs, facilitating and delivering programs, setting up events, serving meals, cleaning, etc. Our volunteers donate an average of 1,800 hours of their time each month.

- 1,800 (hours per month) X 12 months = 21,600 (hours per year)
- valued at \$11.35/ hour (minimum wage) = \$245,160.00 per year

PURPOSE OF GRANT AND PROPOSED ALLOCATION OF FUNDS:

The purpose of the grant is to replace the flooring and the furnishings in the offices. The flooring in the rest of the facility (main floor) has been updated over the last few years however the offices have not been in over 15 years. The current facilities have been in use since 1988. The furnishings are breaking down renovations done now will save costs overall and will provide a long life of safe, clean, and dignified work space for our senior volunteers.

BENEFITS TO COMMUNITY RESULTING FROM GRANT OR CITY GOALS AND OBJECTIVES THAT WILL BE MET, IF THE GRANT IS APPROVED:

Please refer to Appendix "C" - BENEFITS TO COMMUNITY RESULTING FROM GRANT OR CITY GOALS AND OBJECTIVES THAT WILL BE MET, IF THE GRANT IS APPROVED

DEGREE OF COMMUNITY FINANCIAL SUPPORT OR SPONSORSHIP:

Support from the City of Vernon will help us meet our target to raise 50% of the funding for this project which will position us to apply for the outstanding balance from Kalamalka Rotary in Nov. 2019. Securing these funds will allow us to sustain and maintain our quality services to the senior's citizens of Vernon for years to come.



The Corporation of the City of Vernon

COUNCIL DISCRETIONARY GRANT APPLICATION FORM

DEGREE OF DEMONSTRATED ECONOMIC DEVELOPMENT, ENVIRONMENTAL STEWARDSHIP OR SOCIAL BENEFIT THAT MAY BE GENERATED BY THE AWARD OF A COUNCIL DISCRETIONARY GRANT:

"The Schubert Centre will be contributing to Vernon's economy for years to come. Our seniors will benefit from knowing that the facilities at Schubert Centre are clean and safe and that the City of Vernon values their contribution.

GRANT QUALIFICATION CHECKLIST (please check all that apply):

- Community Based
- Providing a service which is not provided by any other group or organization within the City or which is provided for in another municipality and used by residents
- Must only submit one application per calendar year
- Grant request is not to cover retroactive funding or to cover a deficit

Note: Organizations do not qualify for the discretionary grant program if they are in receipt of regional funding or are receiving grants or other assistance from the City of Vernon.

GRANT REQUIREMENTS (please attach to your grant application):

- Most Recent Set of Financial Statements
- Minutes of Most Recent Annual General Meeting
- List of Members of the Executive (including positions held, address and contact numbers)

In the case of newly formed groups, a budget and information regarding the organization purpose including list of Board of Directors will be sufficient.

Oct 31, 2019

Date

S. Heggeler

Signature

PP: Shirley Higgens

City Hall Address: 3400 30th Street, Vernon BC, V1T 5E6
Inquiries: 250-545-1361
Web: www.vernon.ca

SERVICE PROVIDED TO THE COMMUNITY:

The Schubert Centre alone has over 900 members and there are thousands of other Vernon residents that attend activities at the centre each year. It would be difficult to find someone in the local area that has not been to the Schubert Centre. It is located near approximately 20 apartment buildings for seniors and is on the city bus route. The center and the public transit are wheelchair accessible and conveniently located for all people.

In addition to programs and services for our members, other local community groups that hold regular meetings at the centre include: Old Age Pensioners Organization, Canadian National Institute for the Blind, Red Hatters, Kiwanis, Alcoholics Anonymous, Kalamalka Rotary Club, Toastmasters, Gyro Club, Rebekah, Knights of Columbus, Pythians, Shriners, Women in Business, Weight Watchers, and The Vernon and District Immigrant Services Society.

Other groups or clubs that host meetings and events at the Schubert Centre are: The Diversity Health Fair: a free annual event where local healthcare professionals guide visitors through event displays, and offer free blood sugar and blood pressure tests and teach personal health tips.

Schubert Center is ideal for weddings, celebration of life services, forums, government elections, meetings, seminars, quilting bees, special events (birthdays, reunions, and anniversary parties), employment & health fairs, as well as the annual community events such as the Vernon Winter Carnival.

The members (receive discounted pricing) and non-members participate in the wide range of activities offered including: bus tours, The Café, The Thrift Store, Woodworking room, Exercise room and classes, dancing, shuffleboard, choir, bingo, table tennis, floor curling, crafting, quilting, card & board games, adult day program, and so much more.

Schubert Centre also provides practical support through information sessions & referrals; transportation and housing assistance, arrangement of home supports, medical and financial information, will preparation, documentation and form completion assistance, and the meals on wheels program – which provides meals once a day, three days a week to seniors, persons with disabilities, veterans, and those convalescing.

PLEASE IDENTIFY THE STEPS YOUR ORGANIZATION HAS TAKEN TO ACQUIRE GRANTS FROM OTHER SOURCES:

The steps that our organization has taken to acquire grants from other sources include acquiring quotes from multiple sources, researching and matching criteria of foundations and government grant sources, submitting an application to matching foundations and government (all levels) to meet project costs. It is imperative that we show support from our municipal government to secure funding from other resources. See below the list of applications submitted

NOTE: For many of the provincial and federal funding options an organization must attain a minimum of 50% of the total project cost to be eligible to apply and must be secured prior to the next date for applications.

Office Flooring & Furnishings Replacement Project Revenue and Status of Requests:

Source:	Amount of Request:	Status of Request:
Kalamalka Rotary	\$5,000.00	Non-confirmed (apply Nov)
City of Vernon Discretionary Fund	\$5,000.00	Non-confirmed
Total Project Cost:	\$10,000.00	

BENEFITS TO COMMUNITY RESULTING FROM GRANT OR CITY GOALS AND OBJECTIVES THAT WILL BE MET, IF THE GRANT IS APPROVED:**Benefits to the Community:**

Schubert Centre is a hub of activity, serving our community, from opening to closing every day. The facility is also opened for events after outside of regular daytime hours (evenings & weekends) and the bathrooms are in use day and evening. The renovations will provide accessible, environmentally friendly, and safe bathrooms and will allow us to continue the programs and services for years to come.

City Goal*Create a Vibrant Parks and Recreation System*

- New Seniors Centre planning

Schubert Centre is Vernon's one of two primary Seniors Centre. Having accessible, environmentally friendly, and safe facility ensures that Schubert Centre continues to meet the City's objective of having a centre for seniors and will add value to the Recreation System.

Foster Community Development through Social Planning

- Continue to support the Social Planning Council in the provision of social services to the City, including programs and initiatives to address homelessness, childcare, attainable housing, food security and neighbourhood safety.

Schubert Centre contributes to Food Security by providing affordable meals and working with other stakeholders and community groups to provide subsidized nutrition through the Meals on Wheels initiative (see brochure). We require accessible and safe office area to remain compliant with health regulations, fire codes, bylaws, and other statutory regulations..

- Work with community groups and agencies to support youth and senior oriented initiatives

Schubert Centre is unparalleled in providing programs, services, and senior oriented initiatives to the citizens of Vernon. Our aging infrastructure places us at risk of not being able to provide the level of services that Vernon has come to expect. Our renovations will position us to contribute to the City of Vernon's goal of senior oriented initiatives for years to come.

Schubert Centre Society
Comparative Income Statement

	Actual 04/01/2018 to 03/31/2019	Actual 04/01/2017 to 03/31/2018	Percent
REVENUE			
PROGRAM REVENUE			
Crafts	1,518.50	2,509.10	-39.48
Cards/Programs/Dance/Curling	8,277.00	8,391.11	-1.36
Thrift Shop	34,060.55	29,935.55	13.76
Van Trips	33,697.00	15,570.99	116.41
City Bus Tickets Sold	255.00	949.00	-73.13
50/50 - Raffle Tickets	2,281.25	3,688.85	-38.16
Jack Ball Revenue	9,040.00	2,258.00	300.35
Liquor Revenue	47,426.03	47,880.42	-0.95
TOTAL GENERAL REVENUE	136,555.33	111,183.02	22.82
Catering - Revenue	299,650.73	282,278.01	6.15
Meals On Wheels Revenue	50,322.72	54,035.98	-6.87
Coffee Shop & Birthday Lunch	144,833.72	138,573.72	4.52
Special Programs	2,763.50	4,612.50	-40.09
TOTAL FOOD REVENUE	497,570.67	479,500.21	3.77
Bingo Monday - Gaming	65,099.75	17,886.05	263.97
Breakopen Tickets Sold	8,715.50	8,405.50	3.69
TOTAL BINGO & BREAKOPE...	73,815.25	26,291.55	180.78
Donations- receipted	20,413.65	5,910.00	245.41
Donations In Kind - receipted	6,464.40	906.45	613.16
Donations - Cash (no receipt)	7,984.30	234,833.62	-96.60
Gift Certificate	225.00	0.00	0.00
Grants	31,234.64	90,315.88	-65.42
Facility Rentals	85,734.25	77,308.65	10.90
Interest Income	0.00	12.79	-100.00
Management Fee - Catherine ...	0.00	204.88	-100.00
Revenue from Catherine Gard...	22,061.10	19,660.74	12.21
Advertising Revenue	1,498.20	1,446.00	3.61
Memberships	26,780.41	27,445.12	-2.42
Gratuities	630.36	76.30	726.16
Miscellaneous Revenue	4,985.34	5,641.30	-11.63
ATM Surcharge Revenue	2,796.00	2,350.00	18.98
Shirts and Hats	482.94	902.91	-46.51
TOTAL SALES REVENUE	211,290.59	467,012.64	-54.76
Deferred Contribution Revenue	0.00	397,116.52	-100.00
PST Revenue	374.45	394.96	-5.19
TOTAL REVENUE	919,606.29	1,481,498.90	-37.93
TOTAL REVENUE	919,606.29	1,481,498.90	-37.93
EXPENSE			
DIRECT COSTS			
Crafts	321.89	219.40	46.71
Thrift Shop	4,211.66	1,330.13	216.64
Van Trips	11,488.79	9,493.14	21.02
City Bus Tickets Purchased	585.00	350.00	67.14
Fuel	12,656.34	9,834.50	28.69
50/50 Draw/Raffle	215.00	157.51	36.50

Schubert Centre Society
Comparative Income Statement

	Actual 04/01/2018 to 03/31/2019	Actual 04/01/2017 to 03/31/2018	Percent
Other Programs	8.00	162.50	-95.08
Liquor Cost	26,990.11	37,896.12	-28.78
TOTAL GENERAL EXPENSE	56,476.79	59,443.30	-4.99
Catering	5,523.55	12,474.75	-55.72
Meals on Wheels Expense	5,816.63	5,127.77	13.43
Laundry	40,576.51	26,152.09	55.16
Food Costs	200,034.69	211,926.85	-5.61
Freight Charge	0.00	61.46	-100.00
Coffee Shop & Lunch	2,725.12	1,140.05	139.04
Kitchen Wages	59,609.11	52,495.83	13.55
Kitchen Expense	1,721.30	1,953.68	-11.89
Equipment/Dishes	3,707.25	2,808.78	31.99
Special Programs	1,593.93	1,750.00	-8.92
Birthday Lunches	0.00	72.62	-100.00
Wages - Catering	32,927.28	25,721.30	28.02
Wages - Food Service	123,126.64	126,638.25	-2.77
TOTAL FOOD EXPENSE	477,362.01	468,323.43	1.93
Bingo Exp	17,668.35	2,607.84	577.51
Jack Ball Prize	6,025.00	900.00	569.44
TOTAL MONDAY BINGO	23,693.35	3,507.84	575.44
Breakopen Tickets Paid	4,508.35	7,610.83	-40.76
TOTAL BREAKOPEN EXPENSE	4,508.35	7,610.83	-40.76
TOTAL EXPENSES	562,040.50	538,885.40	4.30
OPERATING/GENERAL EXPE...			
ATM Machine	0.00	1,780.00	-100.00
Accounting & Consulting	3,895.00	4,084.62	-4.64
Bookkeeping	12,921.38	11,492.08	12.44
Consulting Fees	2,050.00	8,517.57	-75.93
Advertising & Promotion	16,457.40	31,307.81	-47.43
Mortgage Interest & Fees	139,297.98	144,716.68	-3.74
Bank & Service Charges	8,977.76	2,138.45	319.83
Penalties & Interest	1,566.51	4,796.71	-67.34
Donations	125.00	1,695.00	-92.63
Insurance	12,612.30	12,001.00	5.09
Insurance Claim 2017	0.00	787.86	-100.00
Entertainment	4,500.00	3,829.09	17.52
Bad Debts	0.00	126.00	-100.00
Legal Fees	842.35	0.00	0.00
Miscellaneous	5,539.20	-2,069.14	-367.71
cash over/short	-278.27	41.96	-763.18
Office, Postage, Printing, Freight	19,430.33	17,158.27	13.24
Shirts & Hats	227.20	613.89	-62.99
Permits/Licenses	2,515.00	1,730.71	45.32
Rep & Maint - Building	6,218.50	9,823.99	-36.70
Rep & Maint - Equipment	22,627.12	13,823.34	63.69
Rep & Maint - Grounds	5,838.41	7,137.55	-18.20
Rep & Maint - Janitor & Setup	69,780.73	39,637.86	76.49
Security	1,318.19	594.37	121.78
Supplies - Janitorial	19,358.15	18,965.05	2.07
Travel and Entertainment	0.00	1,419.01	-100.00

Schubert Centre Society
Comparative Income Statement

	Actual 04/01/2018 to 03/31/2019	Actual 04/01/2017 to 03/31/2018	Percent
Telephone & Fax	3,468.28	6,297.67	-44.93
Utilities - Cable	478.51	1,782.97	-73.18
Utilities - Heat	13,405.84	15,550.41	-13.79
Utilities - Hydro	37,375.68	40,074.37	-6.73
Utilities - Water & Sewer	42,953.51	3,271.51	1,212.96
Utilities - Garbage Disposal	11,085.52	8,666.21	27.92
Wages	120,011.95	135,817.65	-11.64
Wages - CPP	5,546.73	6,757.23	-17.91
Wages - EI	6,338.51	6,536.51	-3.03
Wages - WCB	2,877.76	3,242.06	-11.24
Wages - Casual	4,481.30	5,285.00	-15.21
Wages Catherine Gardens Cle...	0.00	23.44	-100.00
Payroll Expenses	139,256.25	157,661.89	-11.67
Amortization exp.	0.00	65,402.13	-100.00
TOTAL OPERATING EXPENS...	603,843.83	634,756.89	-4.87
TOTAL EXPENSE	1,165,884.33	1,173,642.29	-0.66
NET INCOME	-246,278.04	307,856.61	-180.00

**SCHUBERT CENTRE SOCIETY
ANNUAL GENERAL MEETING
June 26, 2019**

1. Call to Order

The meeting was called to order by President Ed at 2 pm; there were approximately 50 people in attendance

2. Financial Report

Due to changes (eg. bookkeeper, accounting firm ownership) no financial statements were presented at the meeting; as soon as the financial statements are complete, they will be made available

Financial information shared – revenue approximately \$500,000; the operating loss will be consistent with the past; going forward revenue sources will provide better financial results

Schubert Centre has received a Summer Student Grant, a Horizons Grant for the updating of washrooms, a Meals on Wheels Grant

The motion to accept the financial report as presented was initiated by Wilma Boulter, and seconded by Eleanor Heinz – motion carried

3. Appointment of Accountant Amber Bell CPA

The motion to appoint Amber Bell CPA as Schubert Centre Society Accountant was initiated by Joan McNichol and seconded by Sue Slater – motion carried

4. Review of Minutes of 2018 AGM

Question arose about Catherine Gardens being a "Society" under the Schubert Centre Society – questioner wanted an explanation of how this is possible – because Catherine Gardens is its own Society and maintains its own Society Certificate; response – Catherine Gardens Certificate is one of Incorporation; Catherine Gardens Society is separate from Schubert Centre Society; Schubert Centre owns Catherine Gardens

Question arose about Jack Gareb being Senior General Manager and does that mean there will be an Assistant Manager: response – the strategic planning exercise is looking at various options and opportunities in the future; nothing has changed at this time

The motion to accept the minutes of the 2018 AGM was initiated by Val Lynch and seconded by Betty Anderson – motion carried

5. President's Report

A number of positive changes taking place at Schubert Centre; the previously mentioned strategic planning exercise being carried out by the Schubert Centre Board

Schubert Centre has acquired a new bus – now has a fleet of two buses; the tour business continues to grow and do well – it is expected that the new bus will aid the creation of more general revenue

The Thrift Store continues to do well; the catering is very busy; the pro wrestling matches are providing good shows and good turnouts; bingo is doing well

President's Report concluded with a "thank you" to the volunteers and pointed to positive signs within the Schubert Centre: those attending the AGM showed their appreciation for the events and services provided by the Schubert Centre with their applause

6. Senior General Manager's Report

The report began with a thanks to the volunteers, and thanks to the catering, food and beverage staff; it's a tough business to be profitable in, and the Management and Board accepts that challenge

And thanks to the members for their involvement and suggestions

Follow up on why Jack is called the Senior General Manager – allows Jack, and the Schubert Centre to access more Grants

7. Department Supervisors' Report

Sue Slater: tour and tour bus doing very well, also commented on the second bus; offered a thanks to the bus drivers and feels comfortable that the tour business is doing well

Wilma Boulter: reception desk – thanked the volunteers for doing a great job and shared that there is always a need for volunteers for the reception desk

Diane Weaver: coffee shop – thanked the volunteers for an exceptional job, and shared that there is always a need for more volunteers

Eleanor: sing for your life – on Tuesday's – don't have to know how to sing, just need to like to sing

Jackie: catering – in need of volunteers

Val Lynch: membership – reported that there are 858 members

Carol: meals on wheels – averaging 100 to 120 meals – In need of volunteers

At this time there was a recognition of Wilma Boulter for all the effort and good results she provides for the Schubert Centre – always pleasant and always looking for ways to help out

A motion to approve the actions of the Board was initiated by Joan McNichol and seconded by Cheryl Gareb – motion carried

8. Elections

President Ed Howard was acclaimed for another term

Secretary Cam Luckock was acclaimed

Treasurer Darren Dingwall was acclaimed for another term

Directors Cecile Johnson and Paul Murphy were acclaimed for additional terms

9. Previous Business

There was no previous business to discuss

10. New Business

It was suggested that Catherine Gardens have a page in the Schubert Centre newsletter – this will go to the Agenda for the next Schubert Centre Society Board Meeting

11. Motion to Adjourn

A motion to adjourn was initiated by Eleanor Heinz and seconded by Cecile Johnson – motion carried

The meeting concluded at 3:05 pm

RECEIVED 06/20/2019 08:54AM -2502751293
 2019-06-20 09:05

GALLACHER GROUP
 Schubert Centre 2505492249 >> 2502751293

P 1/1

Date NOVEMBER 22 2019



QUOTE/INVOICE

1657485 Alberta Inc.
 4413 - 29th Street, Vernon, BC V1T 5B7
 PHONE: (250) 545-4454 · FAX: (250) 545-5885
 Email: cjvcarpetone@shaw.ca

INVOICE TO:

Name SCHUBERT CENTRE / ATTENTION: JACQUES Install Address: _____
 Address: 3505-30 ALENNIC, VERNON, B.C.
 Phone: 250-549-4301 Cell: 250-558-6792 Email: info@schubertcentre.ca

P.O. No. _____ Pick-up Special Instructions _____
 Salesman JACQUE/CHARLIE Install
 GST # 82374 - 2481 RT0001

QUANTITY	DESCRIPTION	UNIT PRICE
	DINING ROOM, SERVICE COUNTERS WALK AREAS	
770 SQ. FT.	TO SUPPLY AND INSTALL NEW VINYL PLANK. THIS INCLUDES FLOAT OVER EXISTING V.C. FLOOR TILES IN DINING AREA + COMMERCIAL SHEET VINYL IN SERVICE COUNTER WALK AREAS; REMOVE AND DISPOSE OF OLD RUBBER BASE; SUPPLY AND INSTALL NEW 4" BLACK RUBBER BASE; SUPPLY AND INSTALL NEW VINYL REDUCER MOLDINGS AT EDGES OF CERAMIC TILES	

(NOTE: - THIS DOES NOT INCLUDE FURNITURE MOVING.
 - IF ANY ADDITIONAL PREPARATION IS REQUIRED, WE WILL PROVIDE PRICE BEFORE WORK BEGINS FOR APPROVAL)

REGULAR PRICE 13,890.00	LOYALTY PRICE	SUBTOTAL	12,360.00
G.S.T. 694.50		G.S.T.	618.00
TOTAL \$14,584.50		P.S.T.	
		TOTAL	12,978.00

FIFTY PERCENT (50%) DEPOSIT REQUIRED UPON APPROVAL DEPOSIT 6,500.00

TERMS AND CONDITIONS
 Payment in full required upon installation.
 Interest at 2% per month (24% per annum) will be calculated on overdue accounts.

PAYMENT PAID BY	
BALANCE	
FINAL PAYMENT PAID BY	

 VENDOR'S APPROVAL

 PURCHASER'S SIGNATURE



Corbett Office Plus

3306 - 30th Avenue
 Vernon BC V1T 2C8

Garret Murphy
 (250) 549-2236
 garret@corbettoffice.com

Bill To:





Jack Gareb
Schubert Centre Society
 3505 - 30th Avenue
 Vernon BC V1T 2E6
 P: (250) 549-4201 E: jack@schubertcentre.ca

Ship To:

Jack Gareb
Schubert Centre Society
 3505 - 30th Avenue
 Vernon BC V1T 2E6
 P: (250) 549-4201 E: jack@schubertcentre.ca

Date: 6/2/2019
 Valid Until: 8/31/2019
 Quote No.: GM060219
 Sales Rep: Garret Murphy
 Schubert Centre

Quote includes delivery & installation

Item	Qty.	Product	Description	Unit	Sell Price	Extended
FILE CABINETS						
	1	2 MVL1936P4	MVL1900 LATERALS - Four drawer high Lateral File. 4-12" opening fixed fronts. Recessed Angled Full Pulls. Side-to-side file bars, Counterweights & Lock included.		\$599.99	\$1,199.98
			20-Finish Selection BLK Black			
					Category Subtotal	\$1,199.98
FREESTANDING CASEGOODS						
	2	4 INV-3072DS	DESK SHELL		\$306.45	\$1,225.80
			HDL INV COLOR EZ EVENING ZEN			
	3	4 INV-FPUF	FREESTANDING PED - BBF - NO TOP		\$280.61	\$1,122.44
			HDL INV COLOR EZ EVENING ZEN HDL HANDLE COLOR SL SILVER (EZ,GD ONLY)			
					Category Subtotal	\$2,348.24
SEATING						
	4	4 MVL2803F	IBEX MESH - Multi-Tilter, Upholstered Seat and Mesh Back. Air-flow mesh back. Infinite position tilt-lock and tilt-tension adjustment. Independent back & seat angle adjustment. Forward seat angle		\$329.99	\$1,319.96
			10-Textile Series Selection 01 UPHOLSTERY GRADE 01 01FABRIC JENY JENNY JENY JN02 EBONY 20-Finish Selection BLK (S)Black Finish 60-Caster Selection CX (S)C1-Black 2"Dual-Wheel Casters			
	5	8 MVL2819	IBEX GUEST - Upholstered Seat and Upholstered Back Guest Chair. Fully upholstered seat and back. Stacks 5 high. Back exterior is upholstered in Black Jenny fabric. Comes fully assembled. Wall saver		\$253.94	\$2,031.52

Quote includes delivery & installation

Item	Qty.	Product	Description	Sell Price	
				Unit	Extended
		10-Textile Series Selection	02	UPHOLSTERY GRADE 02	
		02FABRIC	BNDL	LUXHIDE(BL)	
		BNDL	BL20	BLACK	
		20-Finish Selection	BLK	(S)Black Finish	
				Category Subtotal	\$3,351.48
GST 5%					\$344.99 \$344.99
PST 7%					\$482.98 \$482.98
				Total:	\$7,727.67

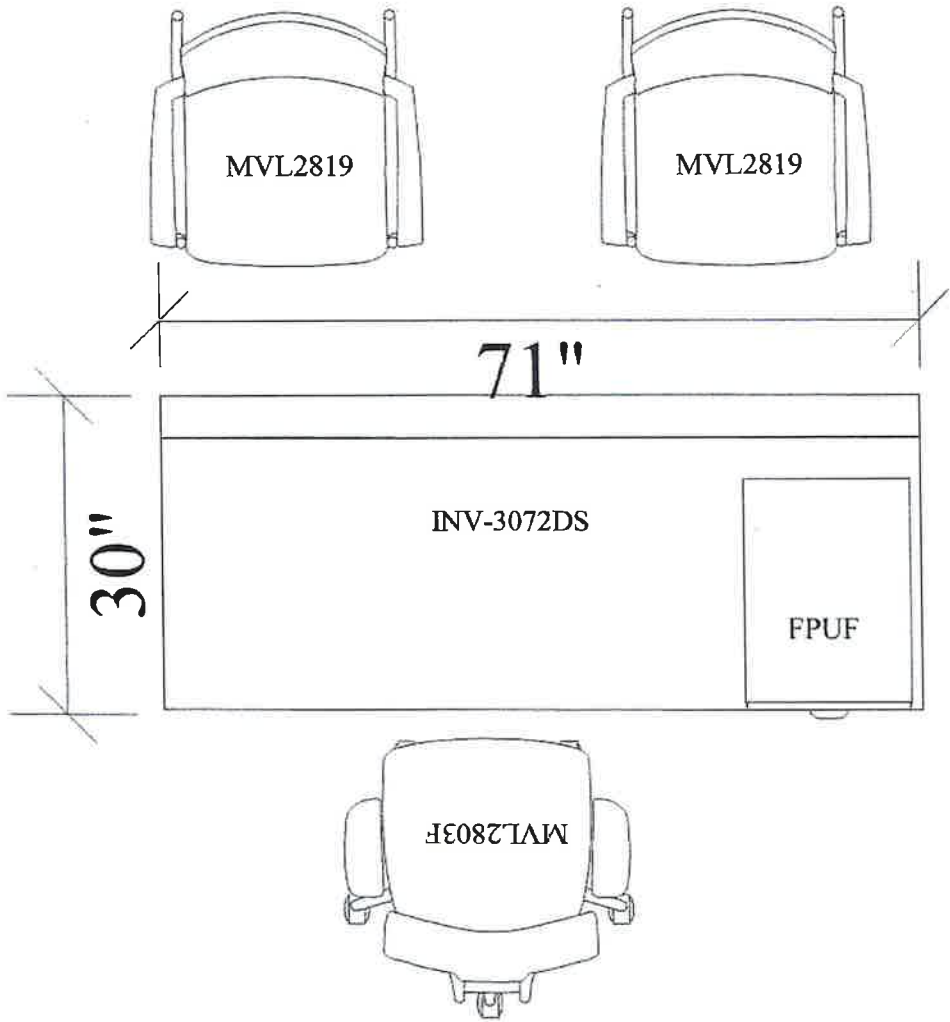

Schubert Centre Society
Jack Gareb

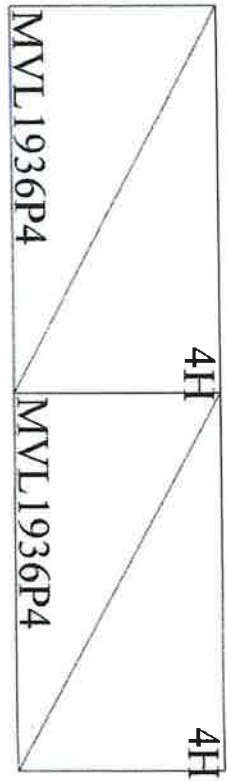

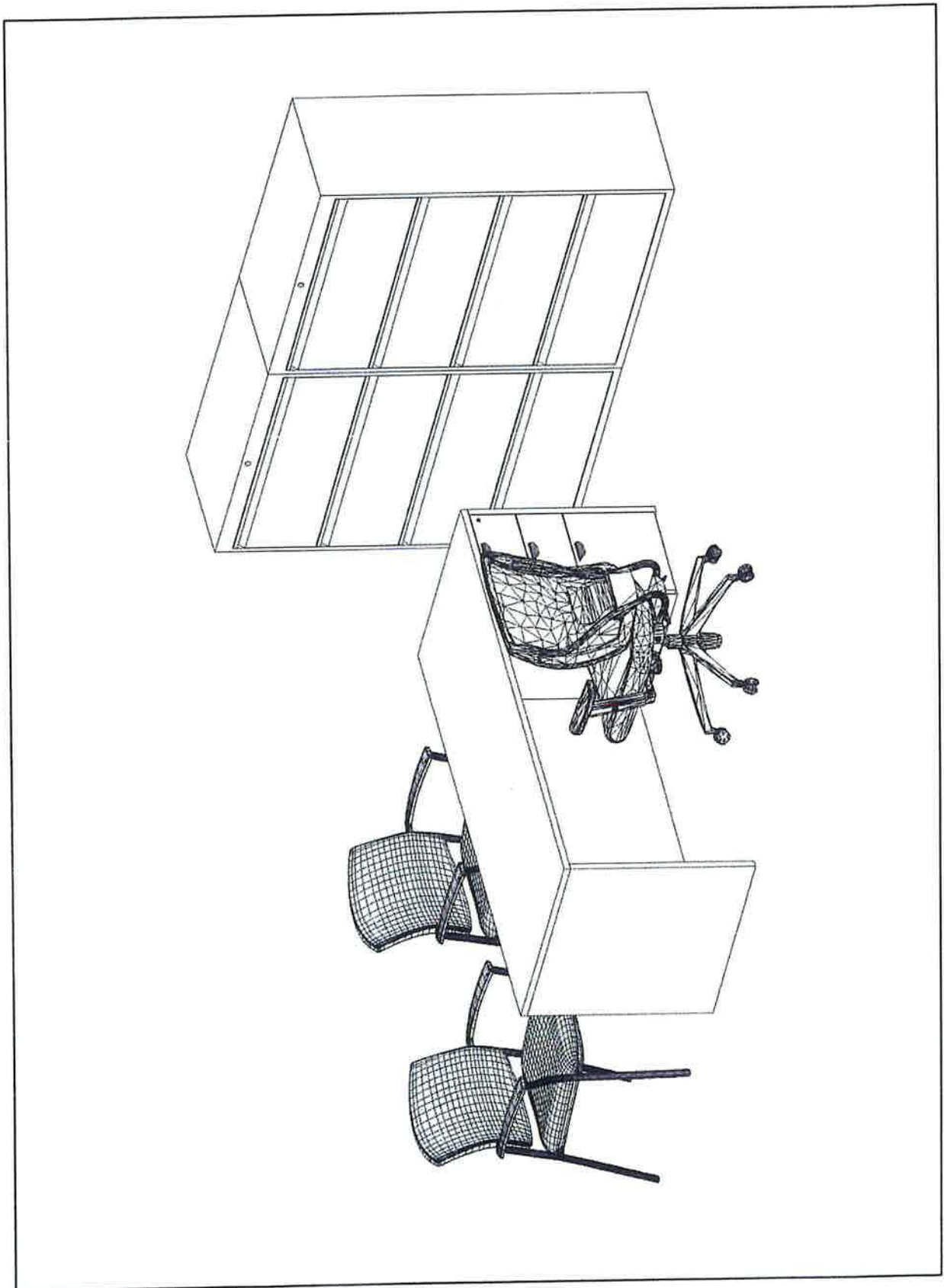



ERIC FOSTER, M.L.A.
(Vernon-Monashee)
Province of British Columbia

Constituency Office:
3209 - 31st Avenue
Vernon, B.C. V1T 2H2
Phone: 250 503-3600
Fax: 250 503-3603
Website:

Vernon June 20, 2019

To whom it may concern:

As the MLA for Vernon Monashee, I am pleased to provide this letter of support for the Schubert Centre Society's grant application.

The Schubert Centre, located in Vernon, BC is a social and recreational facility for seniors operating since 1984. The facility strives to help seniors maintain a good quality of life by providing services to foster a healthy lifestyle.

Schubert Centre is applying for this grant to replace and renovate the flooring, desks, filing cabinets, reception & office chairs which are in dire need of replacement and repair as they haven't been upgraded in over 15 years.

I am hoping that you will give favourable consideration to this grant application.
Thanking you in advance.

Sincerely,

Eric Foster MLA
Vernon -Monashee



The Corporation of the City of Vernon COUNCIL DISCRETIONARY GRANT APPLICATION FORM

IMPORTANT: The deadline for Council Discretionary Grant Applications are semi-annual being April 30 and October 31 each calendar year.

Applications will only be accepted during the intake periods of April 1 - April 30 and October 1 to October 31. Applications must be submitted to the Director of Financial Services no later than 4:00pm on the application deadline (April 30th and October 31st), if City Hall is closed that day, on the next working day that City Hall is open.

Applicants may run the risk of grant funding being depleted if waiting to apply until the October intake deadline.

If grant applications are received after the cut off periods they will be returned to the applicant and must be submitted at the next intake period.

Please note: Incomplete applications will not be considered

ORGANIZATION INFORMATION

NAME OF ORGANIZATION APPLYING FOR COUNCIL DISCRETIONARY GRANT:	Sovereign Lake Nordic Club - #S0014629
CONTACT PERSON:	Troy Hudson (or alternate, Hugh Hamilton)
ORGANIZATION MAILING ADDRESS:	Box 1231 Vernon, BC V1T 6N6
BUSINESS PHONE:	(250) 558-3036 [REDACTED]
EMAIL ADDRESS:	troy@sovereignlake.com
REGISTERED NON PROFIT SOCIETY INCORPORATION NUMBER (required):	50014629

"Personal information contained on this form is collected under the *Freedom of Information and Protection of Privacy Act* and will be used only for the purposes of responding to your request".

**City Hall Address: 3400 30th Street, Vernon BC, V1T 5E6
Inquiries: 250-545-1361
Web: www.vernon.ca**



The Corporation of the City of Vernon

COUNCIL DISCRETIONARY GRANT APPLICATION FORM

ORGANIZATION GOALS, OBJECTIVES AND ACTIVITIES:

Sovereign Lake Nordic Club (SLNC) is Canada's largest cross-country ski club with more than 1,800 members. Headquartered in Silver Star Provincial Park near Vernon, BC, SLNC is a community-based, not-for-profit club. Our mission is: "As stewards of the Silver Star Provincial Park, the Sovereign Lake Nordic Club operates a world-class cross-country ski venue for the recreational, social and economic benefit of Vernon and the North Okanagan Region." In addition to members' programs, SLNC operates the ski & snowshoe trails for BC Parks and typically hosts >50,000 visitor-days each year.

SERVICE PROVIDED TO THE COMMUNITY:

SLNC has a long track record of providing affordable winter sports for the Vernon community. The legacy of Nationals 2020 will include a higher profile for the Nordic skiing and for Vernon, based on the extensive media coverage that comes with a national championship. Nordic skiing is an active-for-life sport and raising the awareness of the excellent facilities at Sovereign Lake and adjacent Silver Star Resort (combined 105 km of trails groomed daily) will encourage participation at all levels. This is part of SLNC's ongoing commitment to build stronger community links including our S'Cool Ski Program which brings over 1700 Vernon area school kids to SLNC annually and our Jess4Kids Ski Foundation delivers programs to more than 250 children each season that have special needs, come from low income families, or attend local schools with few resources.

A PROFILE AND HISTORY OF THE ORGANIZATION AND ITS ACCOMPLISHMENTS:

SLNC (formerly the North Okanagan Cross-Country Ski Club) was founded in 1974 as a spin-off from the original 1939 Vernon Ski Club that had evolved to emphasize downhill skiing. Since then this Vernon-based club has grown to be Canada's largest Nordic skiing club (see <https://www.sovereignlake.com/>). We operate the ski & snowshoe trails in Silver Star Provincial Park on behalf of BC Parks and provide a range of programs for members and visitors, including the S'Cool Ski Program (see above), learn-to-ski programs for children and adults, racing, biathlon, and Canada's largest Master's ski program (>200 participants). SLNC has hosted many provincial, North American, and International races, including a World Cup Race in 2005 and the Master's World Championships in 2013. SLNC has made Vernon "the place to cross-country ski" in Western Canada, serving the local community and bring many visitors to Vernon.

PLEASE IDENTIFY THE STEPS YOUR ORGANIZATION HAS TAKEN TO ACQUIRE GRANTS FROM OTHER SOURCES:

The grant will help SLNC to host the 2020 Ski Nationals. We have applied for and successfully secured a Hosting Grant from ViaSport BC for \$7,500. We have also applied for a Canadian Experiences Fund (CEF) grant from the federal Western Economic Diversification agency.

To date we have also secured approximately \$35,000 in corporate sponsorship and approximately \$25,000 in in-kind support. The fund-raising effort is continuing. Please see the Ski Nationals 2020 web site for information on sponsors to date (<https://www.skinationals2020.ca/>)

City Hall Address: 3400 30th Street, Vernon BC, V1T 5E6

Inquiries: 250-545-1361

Web: www.vernon.ca



The Corporation of the City of Vernon

COUNCIL DISCRETIONARY GRANT APPLICATION FORM

GRANT REQUEST

(You may wish to provide attachments, please note below where these items can be found.)

<p><u>AMOUNT OF REQUEST:</u></p> <p>SLNC is requesting \$20,000 from the City of Vernon Council Discretionary Grant program.</p>
<p><u>IN-KIND SERVICES: (please describe and include cost)</u></p> <p>Not applicable.</p>
<p><u>PURPOSE OF GRANT AND PROPOSED ALLOCATION OF FUNDS:</u></p> <p>The grant will help support SLNC's hosting of the Canadian National Championships for Nordic skiing. The event will run from March 25 until April 2, 2020 and will include eight days of racing and a training day. It is sanctioned by FIS and racers earn points towards participation in World Cup and Olympic Games. The races will include sprints, middle and long distances, and relays for men and women aged 12 to 50+. Racers will range from up-and-coming young athletes to members of Canada's national and provincial teams, as well as some athletes from the US and Europe. We expect 650-800 athletes plus 400 coaches and support people. Approximately 80% will be from outside the Okanagan-Shuswap region. The funds from the City of Vernon will be allocated to the rental of tents and trailers from local suppliers to serve as shelters for ski waxing and servicing. This is a requirement imposed by the national (Nordiq Canada) and International (FIS) sporting authorities for our sport.</p>
<p><u>BENEFITS TO COMMUNITY RESULTING FROM GRANT OR CITY GOALS AND OBJECTIVES THAT WILL BE MET, IF THE GRANT IS APPROVED:</u></p> <p>The event will bring 1050-1200 people to Greater Vernon, with approximately 80% requiring overnight accommodation and meals for 6-10 days (about 7,200 person-days). The visitors are expected to generate significant business for local grocery stores, restaurants, gas stations, and sporting and specialty shops. In addition to the direct and indirect economic benefits of the 2020 Ski Nationals, the event will raise the tourism and business profile of Vernon by attracting visitors from across Canada and beyond. Our experience from hosting previous World Cup, Masters World Cup, and Nor-Am events is that many participants returned to the Okanagan for a vacation after having first visiting for our races.</p>
<p><u>DEGREE OF COMMUNITY FINANCIAL SUPPORT OR SPONSORSHIP:</u></p> <p>As noted above, we have secured about \$35,000 in community sponsorship funding plus an additional \$25,000 in local in-kind support. Confirmed local sponsors include Stussi Sport, Kal Tire, Associated Environmental, MQN Architects, Sproing Creative, Vernon Lodge, Paradigm Wellness, and the Kelowna International Airport (YLW). Our overall sponsorship plus grants target is \$90,000 and we are working hard towards this goal. However, business budgets are tight and the requested grant funds from the City of Vernon are needed to help make the event a success.</p>

City Hall Address: 3400 30th Street, Vernon BC, V1T 5E6
Inquiries: 250-545-1361
Web: www.vernon.ca

SOVEREIGN LAKE NORDIC CLUB
Financial Statements
Year Ended May 31, 2019
(Unaudited - See Notice To Reader)

SOVEREIGN LAKE NORDIC CLUB
Index to Financial Statements
Year Ended May 31, 2019
(Unaudited - See Notice To Reader)

	Page
NOTICE TO READER	1
FINANCIAL STATEMENTS	
Statement of Financial Position	2
Statement of Changes in Net Assets	3
Statement of Revenues and Expenditures	4
Notes to Financial Statements	5 - 6
Sales Schedule <i>(Schedule 1)</i>	7

ROMEI PLUMMER LLP

CHARTERED PROFESSIONAL ACCOUNTANTS

PARTNERS

MARIO E. ROMEI, B.B.A., C.P.A., C.A.*
C. OLAF PLUMMER, C.P.A., C.A., T.E.P.*

*INCORPORATED PROFESSIONALS

3202C - 32nd AVENUE
VERNON, B.C.
V1T 2M5
TELEPHONE: (250) 542-1336
FAX: (250) 542-3040

NOTICE TO READER

On the basis of information provided by management, we have compiled the statement of financial position of Sovereign Lake Nordic Club as at May 31, 2019 and the statements of changes in net assets and revenues and expenditures for the year then ended.

We have not performed an audit or a review engagement in respect of these financial statements and, accordingly, we express no assurance thereon.

Readers are cautioned that these statements may not be appropriate for their purposes.

Vernon, British Columbia
June 27, 2019

Romei Plummer LLP
CHARTERED PROFESSIONAL ACCOUNTANTS

SOVEREIGN LAKE NORDIC CLUB

Statement of Financial Position

May 31, 2019

(Unaudited - See Notice To Reader)

	2019	2018
ASSETS		
CURRENT		
Cash	\$ 283,088	\$ 228,538
Term deposits	72,784	101,539
Accounts receivable	3,623	14,397
Inventory	7,465	8,209
Prepaid expenses	8,870	7,495
Prepaid deposits	46,604	-
	422,434	360,178
EQUIPMENT <i>(Note 3)</i>	277,951	259,396
RESTRICTED CASH <i>(Note 4)</i>	467,680	137,785
	\$ 1,168,065	\$ 757,359
 LIABILITIES AND NET ASSETS		
CURRENT		
Accounts payable and accrued liabilities	\$ 5,062	\$ 2,818
Wages payable	9,946	2,468
Employee deductions payable	3,536	3,814
	18,544	9,100
DEFERRED CONTRIBUTIONS <i>(Note 5)</i>	249,770	-
LONG TERM DEBT	29,625	47,542
	297,939	56,642
 NET ASSETS		
Operating fund	387,286	351,078
Capital fund	482,823	348,648
Gaming fund	17	991
	870,126	700,717
	\$ 1,168,065	\$ 757,359

ON BEHALF OF THE BOARD

_____ Director

_____ Director

See notes to financial statements

SOVEREIGN LAKE NORDIC CLUB
Statement of Changes in Net Assets
Year Ended May 31, 2019
(Unaudited - See Notice To Reader)

	Operating Fund	Capital Fund	Gaming Fund	2019	2018
NET ASSETS - BEGINNING OF YEAR	\$ 351,078	\$ 348,648	\$ 991	\$ 700,717	\$ 526,901
Excess of revenues over expenses	222,643	(52,260)	(974)	169,409	173,816
Capital additions	(57,318)	57,318	-	-	-
Inter-fund transfers	(129,117)	129,117	-	-	(497)
Grant	-	-	-	-	21,400
Expenditures on restricted fund	-	-	-	-	(20,903)
NET ASSETS - END OF YEAR	\$ 387,286	\$ 482,823	\$ 17	\$ 870,126	\$ 700,717

SOVEREIGN LAKE NORDIC CLUB
Statement of Revenues and Expenditures
Year Ended May 31, 2019
(Unaudited - See Notice To Reader)

	2019	2018
SALES (Schedule 1)	\$ 894,369	\$ 781,585
COST OF SALES (Schedule 1)	<u>126,139</u>	<u>89,757</u>
GROSS PROFIT (86%; 2018 - 89%)	<u>768,230</u>	<u>691,828</u>
OTHER INCOME		
Donations	3,850	536
Grants	22,400	21,400
Interest	1,341	1,544
Memberships	35,160	33,540
Rentals	<u>66,029</u>	<u>56,315</u>
	<u>128,780</u>	<u>113,335</u>
	<u>897,010</u>	<u>805,163</u>
EXPENSES		
Accounting fees	22,625	25,003
Advertising and promotion	14,312	14,448
Business taxes and licences	102	1,025
Donations	2,605	1,397
Fuel	39,995	49,046
Insurance	12,797	15,851
Interest and bank charges	22,318	19,237
Interest on long term debt	2,277	3,006
Meetings and conventions	3,277	3,564
Office	12,552	9,283
Professional fees	1,931	3,564
Repairs and maintenance	144,141	84,069
Salaries and wages	369,239	323,545
Security	658	300
Telephone	8,015	9,392
Travel	221	3,001
Utilities	<u>19,212</u>	<u>16,904</u>
	<u>676,277</u>	<u>582,635</u>
Excess of sales over expenses from operations	<u>220,733</u>	<u>222,528</u>
Gain on disposal of equipment	<u>8,758</u>	<u>1,008</u>
Excess of revenue over expenses before amortization	<u>229,491</u>	<u>223,536</u>
Amortization	<u>60,082</u>	<u>49,720</u>
Excess of revenue over expenses for the year	<u>\$ 169,409</u>	<u>\$ 173,816</u>

See notes to financial statements

SOVEREIGN LAKE NORDIC CLUB

Sales Schedule

(Schedule 1)

Year Ended May 31, 2019

(Unaudited - See Notice To Reader)

	2019	%	2018	%
Ticket sales				
Sales	\$ 579,701		\$ 501,132	
Cost of sales	6,474		8,844	
Gross profit (% of sales)	<u>573,227</u>	<u>98.88</u>	<u>492,288</u>	<u>98.24</u>
Programs				
Sales	169,248		178,483	
Cost of sales	43,898		24,209	
Gross profit (% of sales)	<u>125,350</u>	<u>74.06</u>	<u>154,274</u>	<u>86.44</u>
Competition				
Sales	68,282		51,851	
Cost of sales	35,708		27,026	
Gross profit (% of sales)	<u>32,574</u>	<u>47.71</u>	<u>24,825</u>	<u>47.88</u>
Events				
Sales	22,762		-	
Cost of sales	6,662		-	
Gross profit (% of sales)	<u>16,100</u>	<u>70.73</u>	<u>-</u>	<u>-</u>
Food				
Sales	26,499		25,873	
Cost of sales	18,241		16,525	
Gross profit (% of sales)	<u>8,258</u>	<u>31.16</u>	<u>9,348</u>	<u>36.13</u>
Merchandise				
Sales	27,877		24,246	
Cost of sales	15,156		13,153	
Gross profit (% of sales)	<u>12,721</u>	<u>45.63</u>	<u>11,093</u>	<u>45.75</u>
Total of all Divisions				
Sales	894,369		781,585	
Cost of sales	126,139		89,757	
Gross profit (% of sales)	<u>\$ 768,230</u>	<u>85.90</u>	<u>\$ 691,828</u>	<u>88.52</u>

See notes to financial statements

SOVEREIGN LAKE NORDIC CLUB

Notes to Financial Statements

Year Ended May 31, 2019

(Unaudited - See Notice To Reader)

1. BASIS OF PRESENTATION

These financial statements are prepared for internal reporting purposes only and do not include all disclosures required under Canadian generally accepted accounting principles.

2. PURPOSE OF THE SOCIETY

Sovereign Lake Nordic Club is incorporated under the Society Act in the province of British Columbia. The purpose of the Society is to promote, train, educate, develop and support cross country skiing and related activities and participants and persons interested in cross country skiing and related activities. Also, to receive, invest, hold, spend and disburse funds and grants to hold and develop property and interest therein and to operate and maintain facilities for that purpose.

The Society is registered as a not-for-profit organization under the Income Tax Act and, accordingly, is exempt from income taxes, provided that certain requirements of the Income Tax Act are met.

3. EQUIPMENT

	Cost	Accumulated amortization	2019 Net book value	2018 Net book value
Equipment	\$ 448,524	\$ 215,955	\$ 232,569	\$ 218,564
Motor vehicles	18,382	4,890	13,492	13,731
Computer equipment	41,392	35,945	5,447	6,448
Rental equipment	45,697	19,880	25,817	19,931
Furniture and fixtures	294,448	293,822	626	722
	\$ 848,443	\$ 570,492	\$ 277,951	\$ 259,396

4. RESTRICTED CASH

Restricted cash consists of internally restricted cash that is for use towards capital expenditures, and the gaming account, which is restricted for use for coaching wages, programs and coaching expenses. Restricted cash also includes a term deposit that matures in November 2019 and is restricted for use as security against payroll overdraft.

	2019	2018
Restricted Cash		
Capital Account	\$ 437,663	\$ 136,794
Gaming Account	17	991
Payroll Overdraft Security Account	30,000	-
	\$ 467,680	\$ 137,785

SOVEREIGN LAKE NORDIC CLUB

Notes to Financial Statements

Year Ended May 31, 2019

(Unaudited - See Notice To Reader)

5. DEFERRED CONTRIBUTIONS

The Club has applied for and received a grant in the amount of \$230,000 from the BC Community Gaming Grants Branch towards purchase of a new PistenBully 400 snow groomer. The Club also received fundraising of \$19,770 (2018 - \$nil) towards the groomer. Contributions received have been deferred as the groomer has not yet been purchased. Deferred contributions will be brought into income over the useful life of the groomer beginning in the year when the groomer is brought into use.

6. FUNDS HELD IN TRUST

The Sovereign Lake Nordic Club is holding funds in trust in the amount of \$11,578 (2018 - \$12,734) for the Jessica Eaman Ski Scholarship Fund. These funds are not reflected in the financial statements.

7. COMPARATIVE FIGURES

Some of the comparative figures have been reclassified to conform to the current year's presentation.



ANNUAL GENERAL MEETING

Oct 17, 2018

NOTE:

OUR 2019 AGM
WAS HELD ON
OCT. 16, 2019. THE
MINUTES WILL BE
AVAILABLE SOON.

Location: Schubert Centre, Vernon BC

Meeting Called to Order: 7:05 pm.

In Attendance: Board of Directors, General manager, staff plus approximately 50 club members.

1. Minutes of Last AGM

- Motion by the Chair to approve Minutes of Oct 18, 2017 Annual General Meeting
- Carried

2. Report of the Chair (Brian Wills)

- review of the 2017-18 Season highlights.
- very successful season: record revenues, record day ticket sales, record membership numbers.
- noted that SLNC success is very weather dependent. Some years are above average some years average or below average.
- SLNC has high operating needs and is heavily capital dependent. SLNC requires strong revenues from above average years to meet our overall operating and capital planning needs

3. Report of the General Manager (Troy Hudson)

- SLNC has lots to be proud of for 2017-18
- success driven largely by our strong cadre of volunteers and excellence amongst our staff
- SLNC is now the largest Nordic Ski Club in North America
- record day ticket sales (over 26,000)
- largest masters Program in Canada (over 150 participants)
- 1700 kids in our S'kool Ski Program,
- strong participation and success in Competitiopns
- strong and growing Programs with new offerings for 2018

- highlighted New Initiatives for 2018
 - Family Snowshoe Pass - "gateway" to new memberships and new skiers.
 - new S'kool Ski base in refurbished Race Office building which will reduce congestion on weekdays.
 - New energies on biathlon
 - renewal of ski rental fleet with skin skis
 - award of host for 2020 Nationals by Cross Country Canada - will be a catalyst for revitalizing volunteerism and program registrations
 - strong competitions for 2018-19 including Dec Nor AM and February BC Winter Games/ Special Olympics
 - many more non-racing events forthcoming
 - special recognition to long-serving retiring staff Howard Maddox and Bill Pfiffer

4. Treasurers Report (Sandra Ecclestone)

- 2018 Year End Financial Reports prepared by Romei Plummer CA, to May 31, 2018 circulated
- recognition of Finance Committee: Troy Hudson, Brian Wills, Guy Morazain and Mike Pennock (Club Accountant)
- SLNC is modernizing business and financial systems
 - improvements in Zone 4 reporting
 - modernizing of accounting practices, streamlining payroll systems, generally tightening financial controls across the organization
- Season highlights
 - record membership numbers
 - strong and growing day ticket sales (\$52.0 - 73.0 K per month from Nov-Mar)
 - strong Supercamp Revenues - highly profitable and well managed
- 3 major revenue streams (Revenues have increase 30% in past 5 Years)
 1. Day Ticket Sales of \$305 K (34 % of total revenue)
 2. Season Passes of \$196 K (22% of total revenue)
 3. Supercamp of \$57 K revenue (6% of total revenue and up 500% since 2014)
- 3 major expense areas
 1. Wages & Salaries of \$324 K (56% of expenses)
 2. Repairs and Maintenance – Trails, Buildings and Equipment \$80 K (14% of expenses)
 3. Fuel for Grooming and other equipment of \$49 K (8% of total expenses)
- Additional comments
 - Balance Sheet is strong; \$48 K remaining on Long Term Debt for Piston Bully payable over the next 2.5 years
 - Total Revenue \$895 K and expenses \$583 K
 - Excess of Revenue over Expenses (after amortization) is \$174 K
 - \$100 K was moved to Capital Fund Account in May and \$40 K was moved in September. A total of \$140 K represents \$70 K for each 2017 and 2018 seasons.

- Summary
 - SLNC is a capital- intensive business. We require approximately \$70.0 K per year to be set aside for major equipment replacement such as Snow Groomers.
 - SLNC has established a Capital Budget which is on track and assisted by strong revenue years such as last season.

5. Lodge Project (Brent Ree)

- presentation on status of day lodge project
- started discussions with BC Parks in 2013
- 2014 - Concept Plan for New Day Lodge connected to Tech Building
 - 12,000 square feet, complete site redevelopment, new parking etc
 - 2013 price tag \$3.5 M
 - 2017 price tag \$4.2 M
 - now apparent that this is unlikely to be funded by BC Parks at that level
 - SLNC needs a "Plan B"

• Plan B -Renovation and Expansion of Existing Day Lodge

- 4000 square foot addition (2000 on each of 2 floors)
- complete renovation of existing lodge including structural, mechanical, as well as new reconfigured office, rental, retail space.
- Structural assessment of existing day lodge done in spring 2018. Determined that it is feasible to build off of existing infrastructure.
- Concept Plan Stage
 - \$2.9 M preliminary cost estimate
 - determined that this is feasible if cost-shared with BC Parks along with Fundraising initiated by SLNC
 - next steps to discuss concept and new funding scenarios with BC Parks.

6. Strategic Plan Review Update (Guy Morazain)

- member surveys and focus groups held in spring 2018
- Draft Plan Presented - available on website
- outlined Mission, Statement of Values
- outlined 5 Goal Areas and 11 Objectives

Building Facilities and Infrastructure

1. Develop site Plan
2. Build New Lodge

Growing Programs

3. Grow non-competitive skiing programs
4. Grow Skill Development Program

5. Grow Competitive Skiing Program

Addressing Climate Change

6. Build higher elevation trails

Enhancing Culture and Community

7. Generate more member involvement

8. Raise profile of Nordic skiing in Vernon

9. host more informal events to build community

Hosting Events

10. Build people capacity and expertise to host events

11. Host National Championships

Next Steps:

- flesh out strategies to meet outlined objectives
- report back to club on progress
- review progress on an annual basis

7. Election of Directors (Kim Taylor)

- Elections Committee Kim Taylor, Doug Geller, Randy Savoie
- recognition of Retiring Directors; Sharon Clarke, Bruce Sandilands
- 5 Directors continuing for 2nd year of 2-year term
 - Sandra Ecclestone, Sylvia Herchen, Mark Nichiporuk, Guy Morazain, Greg Sadesky
- 4 new Directors appointed by acclimation for a 2 year term
 - Lynn Algra, Pat Pearce, Brent Ree, Brian Wills
- Thank you to all returning Board members and those who have stepped up to fill vacancies

8. Club Award Recipients

- SLNC recognized the recipients of the 2017-18 Club Awards who were honoured at the April Final Day Celebration

Volunteer of the Year :	Dave Pearce
Volunteer Coach of the Year:	Avalon Richter
Skier(s) if the Year:	Kath and Jeff Ward
Above and Beyond Award;	George Hutchison
Lifetime Achievement Award:	Randy Shellenberg

Meeting Adjourned 8:10 pm



The Corporation of the City of Vernon COUNCIL DISCRETIONARY GRANT APPLICATION FORM



IMPORTANT: The deadline for Council Discretionary Grant Applications are semi-annual being April 30 and October 31 each calendar year.

Applications will only be accepted during the intake periods of April 1 - April 30 and October 1 to October 31. Applications must be submitted to the Director of Financial Services no later than 4:00pm on the application deadline (April 30th and October 31st), if City Hall is closed that day, on the next working day that City Hall is open.

Applicants may run the risk of grant funding being depleted if waiting to apply until the October intake deadline.

if grant applications are received after the cut off periods they will be returned to the applicant and must be submitted at the next intake period.

Please note: Incomplete applications will not be considered

ORGANIZATION INFORMATION

NAME OF ORGANIZATION APPLYING FOR COUNCIL DISCRETIONARY GRANT:	Upper Room Mission Society
CONTACT PERSON:	Cera Brown
ORGANIZATION MAILING ADDRESS:	3403 27 Avenue Vernon, BC V1T 1S2
BUSINESS PHONE:	250-549-1231
EMAIL ADDRESS:	cera.brown@vernonurm.org
REGISTERED NON PROFIT SOCIETY INCORPORATION NUMBER (required):	

"Personal information contained on this form is collected under the *Freedom of Information and Protection of Privacy Act* and will be used only for the purposes of responding to your request".

City Hall Address: 3400 30th Street, Vernon BC, V1T 5E6
Inquiries: 250-545-1361
Web: www.vernon.ca



The Corporation of the City of Vernon COUNCIL DISCRETIONARY GRANT APPLICATION FORM

ORGANIZATION GOALS, OBJECTIVES AND ACTIVITIES:

Upper Room Mission Society provides emergency services by means of food and basic needs to homeless and vulnerable individuals and families in our community. The Upper Room Mission's primary goal is to express love and care for the underprivileged in our community. We seek to meet their physical, emotional and spiritual needs.

On average, we serve 350 meals a day, 5 days a week. We assist low-income families, the disabled, seniors, and the homeless in our community. We provide a warm, safe environment for people to come in from the cold, enjoy a hot meal, and have their basic needs met in a respectful, welcoming manner.

SERVICE PROVIDED TO THE COMMUNITY:

The Upper Room Mission is a day shelter, dedicated to helping people less fortunate in our community. We provide meals, clothing and household needs, a listening ear when needed, day/short term storage as well we are hoping to be able to offer laundry services full time again. We work closely with other service providers to help our clients find housing, counselling services, medical and dental care, treatment centers, income assistance, court requirements, employment options and education opportunities.

A PROFILE AND HISTORY OF THE ORGANIZATION AND ITS ACCOMPLISHMENTS:

The Upper Room Mission has been serving those less fortunate in our community for close to 40 years now. We were founded in 1980, but actually started up in the early 1970's by a small group of Vernonites.

PLEASE IDENTIFY THE STEPS YOUR ORGANIZATION HAS TAKEN TO ACQUIRE GRANTS FROM OTHER SOURCES:

We applied to Vernon Rotary end of Summer 2019 to help with a temporary fix on the Washing Machine in which we were granted the Funds to help with the temporary fix which was \$1,500

We have recently applied to Kal Rotary Grant but have not heard back yet. We also have applied for the Rural/Reaching Home Grant and hope to hear back if it was granted sometime in the beginning of December.

City Hall Address: 3400 30th Street, Vernon BC, V1T 5E6

Inquiries: 250-545-1361

Web: www.vernon.ca



The Corporation of the City of Vernon

COUNCIL DISCRETIONARY GRANT APPLICATION FORM

GRANT REQUEST

(You may wish to provide attachments, please note below where these items can be found.)

<p><u>AMOUNT OF REQUEST:</u> \$10,376</p>
<p><u>IN-KIND SERVICES: (please describe and include cost)</u> We are in the process of seeking assistance from local appliance businesses to request a in-kind donation of installing our machines. We are also seeking assistance in the removal of the machines. We have been made aware that some plumbing will need to be updated in which we are hoping to receive this as an in kind service also. After research and speaking with businesses we believe we will need to seek out \$7500 in kind services to complete this project. We do not see a problem being able to obtain these services.</p>
<p><u>PURPOSE OF GRANT AND PROPOSED ALLOCATION OF FUNDS:</u> Re-Launch "Loads of Love-Laundry Services" The propose of this program is to offer free laundry services in safe inclusive environment to those in need. We currently have had this service but one of our washing machines is no longer working and our other one is almost dead. Dryers take longer than usual to dry due to them needing to be replaced. Some of the funds will be used to purchase new machines. Two washing machines at \$1839 each. Two Dryers at \$1299 each. Folding Table, Chair and 2 Laundry Hampers totally \$2100. Budget \$2000 for Laundry Soap and Dryer Sheets.</p>
<p><u>BENEFITS TO COMMUNITY RESULTING FROM GRANT OR CITY GOALS AND OBJECTIVES THAT WILL BE MET, IF THE GRANT IS APPROVED:</u> If we are able to relaunch our laundry services this will help us meet the need of clean belongings. These machines will provide those experiencing homelessness/poverty an opportunity to wash dirty clothes, bedding and towels. These machines will also give those a chance to wash/dry wet clothing/blankets for those sleeping rough. Currently there is no place for those experiencing homelessness to wash their belongings for no charge. Upper Room Mission already provides a safe place and by adding this additional service will benefit many.</p>
<p><u>DEGREE OF COMMUNITY FINANCIAL SUPPORT OR SPONSORSHIP:</u> The Upper Room Mission has a good relationship with many local community members/businesses in which will support us with this project. We have many that support us in which allows us to continue supporting those members in need in the Vernon Community.</p>



The Corporation of the City of Vernon

COUNCIL DISCRETIONARY GRANT APPLICATION FORM

DEGREE OF DEMONSTRATED ECONOMIC DEVELOPMENT, ENVIRONMENTAL STEWARDSHIP OR SOCIAL BENEFIT THAT MAY BE GENERATED BY THE AWARD OF A COUNCIL DISCRETIONARY GRANT:

The benefit of this award of a Council Discretionary Grant would be enormous. Being able to offer free laundry service would help so many. Especially a huge benefit to the two senior apartment buildings within walking distance of the Upper Room Mission. Most of those seniors rely on the laundry mat or family members - Laundry mat costs average \$6.50 a load providing only one drying cycle is needed.

Having this service will not only benefit seniors/low-income but also those that are homeless trying to get their life back as clean clothes can be a make or break for a job interview which could be employment and the chance for housing.

GRANT QUALIFICATION CHECKLIST (please check all that apply):

- Community Based
- Providing a service which is not provided by any other group or organization within the City or which is provided for in another municipality and used by residents
- Must only submit one application per calendar year
- Grant request is not to cover retroactive funding or to cover a deficit

Note: Organizations do not qualify for the discretionary grant program if they are in receipt of regional funding or are receiving grants or other assistance from the City of Vernon.

GRANT REQUIREMENTS (please attach to your grant application):

- Most Recent Set of Financial Statements
- Minutes of Most Recent Annual General Meeting
- List of Members of the Executive (including positions held, address and contact numbers)

In the case of newly formed groups, a budget and information regarding the organization purpose including list of Board of Directors will be sufficient.

Oct 30, 2019
Date

Signature

**Vernon Upper Room Mission
Balance Sheet As at 08/31/2019**

ASSET

Current Assest

Class D Equity Shares - Vantage One	6.71	
Vantage membership equity	25.00	
Operating Account	18,793.08	
Reserve Account	1,320.81	
Gaming Account	<u>33,333.33</u>	
Total Vantage One Savings		53,478.93
Petty Cash		502.18
Boutique Float		300.00
GIC #8	30,576.10	
GIC #9	20,384.07	
GIC #10	10,192.03	
GIC #5	40,770.02	
GIC #6	30,577.52	
GIC #7	<u>20,385.01</u>	
Total GIC		152,884.75
Undeposited funds		2,352.75
Credit card clearing account		<u>469.50</u>
Total Cash		<u>209,988.11</u>

Receivables

Receivables		2,512.00
Damage Deposit		<u>9,100.58</u>
Total Receivables		<u>11,612.58</u>

Prepaid Expenses

Insurance	Note 2	6,778.75	
Rent		<u>5,824.39</u>	
Total Prepaid Expenses			<u>12,603.14</u>
Total Current Assets			<u>12,603.14</u>

Other receivables

GST Input tax credit	<u>1,510.78</u>	
Total GST input tax credit		<u>1,510.78</u>
Total other receivables		<u>1,510.78</u>

Land and Buildings

Land		684,000.00
Mission Building		264,196.74
Lot		294,546.00
Accum. Depreciation - Building		<u>-61,631.51</u>
Total Land and Buildings		<u>1,181,111.23</u>

Furniture and Equipment	
Equipment	39,448.63
Furniture	59,433.74
Computers	15,066.80
Accum Depreciation - Equipment	<u>-99,242.65</u>
Net Equipment	<u>14,706.52</u>
Vehicles & Machinery	
Vehicles	33,650.00
Accum Depreciation Vehicles	<u>-31,258.30</u>
Net - Vehicle	<u>2,391.70</u>
Total Capital Assets	<u>2,391.70</u>
TOTAL ASSET	<u><u>1,433,924.06</u></u>
LIABILITY	
Current Liabilities	
Accounts Payable	4,505.39
Wages payables	5,324.08
Benefit Plan Payable	48.00
Vacation payables	11,974.66
Banked Time Payable	865.13
Suspense	612.71
Deferred Capital contributions	62,992.80
Accum.Amort.-Def Capitl Contribute	<u>-22,684.82</u>
Total Current Liabilities	<u>63,637.95</u>
Long Term Liabilities	
Deferred Revenue - BC Gaming Grant	<u>25,000.02</u>
Total Long Term Liabilities	<u>25,000.02</u>
TOTAL LIABILITY	<u>88,637.97</u>
EQUITY	
Owners Equity	
Retained Earnings - Previous Year	1,421,680.94
Current Earnings	<u>-76,394.85</u>
Total Owners Equity	<u>1,345,286.09</u>
TOTAL EQUITY	<u>1,345,286.09</u>
LIABILITIES AND EQUITY	<u><u>1,433,924.06</u></u>

**Vernon Upper Room Mission
Income Statement 11/01/2018 to 08/31/2019**

Actual 11/01/2018 to 08/31/2019

Actual 11/01/2017 to 08/31/2018

REVENUE

Donations

Cash Donations (receipt)	134,739.00	139,021.63
Cash Donations (no receipt)	24,890.46	38,035.98
Donations in Kind (receipt)	13,706.40	12,795.94
Operating Revenue from Fund Raising	<u>173,335.86</u>	<u>189,853.55</u>

Sales

Sales Boutique	311,430.87	338,952.89
Discount sales Boutique (bonuscard)	-1,741.00	-1,909.50
Discount sales Boutique (voucher)	-2,336.00	-2,321.87
Sales Boutique (50% off)	-59,991.25	-65,932.96
Net Sales	<u>247,362.62</u>	<u>268,789.04</u>

Grants

City of Vernon	0.00	1,798.68
BC Gaming	41,666.66	24,999.98
HRDC - Summer Job Grant	1,657.00	0.00
Other Grants	5,240.00	1,000.00
Total Grants	<u>48,563.66</u>	<u>27,798.66</u>

Other grants

Other Grants	16,540.02	0.00
Total other grants	<u>16,540.02</u>	<u>0.00</u>

Other Revenue

Rag Program	1,435.00	2,544.50
Coldest Night of the Year	8,663.36	23,809.19
Interest Revenue	3,263.67	674.33
Bottle Revenue	10,955.61	7,142.05
Other revenue	50,990.99	157.20
Gain/(Loss) on disposal of Asset	0.00	700.00
BC HPS	0.00	11,229.00
Total Other Revenue	<u>75,308.63</u>	<u>46,256.27</u>

Kitchen Contracts

Food Sales	25,994.96	32,493.70
Cook Services	45,188.75	68,559.75
Total Kitchen Contracts	<u>71,183.71</u>	<u>101,053.45</u>

TOTAL REVENUE

	<u>632,294.50</u>	<u>633,750.97</u>
--	-------------------	-------------------

EXPENSE

Cost of Goods Sold

Item Assembly Costs		0.00		181.14
Purchases food (kitchen)	15,763.67		8,455.72	
Donation in kind (food)	13,706.40		12,295.94	
Donation in kind (clothes)	0.00		500.00	
Materials & Supplies - Cleaning	11,485.22		15,727.45	
Purchase Returns	0.00		-124.78	
		<u>40,955.29</u>		<u>36,854.33</u>
Net Purchases		0.00		0.00
Freight Expense		<u>40,955.29</u>		<u>37,035.47</u>
Total Cost of Goods Sold				
Payroll Expenses				
Wages & Salaries		440,152.75		422,852.47
EI Expense		9,930.55		9,585.87
CPP Expense		19,319.15		18,249.94
WCB Expense		3,521.36		3,012.52
Benefits		7,379.28		9,885.54
		<u>480,303.09</u>		<u>463,586.34</u>
Total Payroll Expense				
General & Administrative Expenses				
Board Expenses		78.91		59.82
Advertising & Promotions		-110.53		3,004.03
Bad Debts		0.00		7.70
Business Fees & Licenses		266.50		509.48
Contracts & Consulting		0.00		500.00
Courier & Postage		0.00		511.54
Amortization building	11,008.20		9,907.38	
Amortization Equipment	9,675.98		17,688.30	
Amortization vehicle	1,708.30		1,667.96	
		<u>22,392.48</u>		<u>29,263.64</u>
Total amortization expense				
Fund Raising Costs		56.86		1,451.98
Insurance		6,887.06		6,787.10
Interest & Bank Charges	4,012.74		5,113.73	
Credit Card Charges	971.06		215.54	
Payroll Service Charges	1,963.84		191.25	
		<u>6,947.64</u>		<u>5,520.52</u>
Total Interest and Charges				4,312.96
Office Supplies		3,155.16		
Accounting	4,617.65		3,802.75	
Bookkeeping	9,184.78		9,112.32	
Legal	5,039.74		0.00	
		<u>18,842.17</u>		<u>12,915.07</u>
Total Professional Fees				
Fuel	2,340.45		2,348.19	
Maintenance & Repair	945.57		1,757.07	
Vehicle Insurance	4,012.09		13,934.89	
		<u>7,298.11</u>		<u>18,040.15</u>
Total Vehicle Expense				50,811.02
Rent		48,370.09		
Repair & Maintenance		25,001.75		20,089.55
Staff Appreciation		2,240.71		551.05

Training and Development	108.74	1,068.81
Telephone	4,719.97	5,837.22
Travel & Entertainment	293.43	25.66
Utilities	37,704.75	34,513.28
Misc. expenses	52.66	1,772.65
Computer Maintenance	<u>3,124.51</u>	<u>2,519.59</u>
Total Computer Expense	3,124.51	2,519.59
Gain/loss investment	0.00	0.00
Total General & Admin. Expenses	<u>187,430.97</u>	<u>200,072.82</u>
TOTAL EXPENSE	<u>708,689.35</u>	<u>700,694.63</u>
NET INCOME	<u><u>-76,394.85</u></u>	<u><u>-66,943.66</u></u>

**Upper Room Mission
Receivables
August 31, 2019**

Turning Point		
Cook	(receive in July for the June), estimate	-
Food	(receive in July for the June), estimate	-
		<hr/>
	Balance at August 31, 2019	-
		<hr/>

Contract ended April 1, 2019

Upper Room Mission

Insurance

August 31, 2019

Johnsone Meier	-
Johnsone Meier	5,092.50
ICBC	1,686.25
	<hr/>
	6,778.75

	Total	Expenses by Period			Net
		Prior	Current	Total	
Johnson Meier					
Renewal April 1, 2018 - March 31, 2019	7,799.00	7,799.00	-	7,799.00	-
Renewal April 1, 2019 - March 31, 2020	8,730.00	2,910.00	727.50	3,637.50	5,092.50
ICBC Van					
White Dodge Caravan	4,047.00	2,023.50	337.25	2,360.75	1,686.25
<i>February 1, 2019 - January 31, 2020</i>					
	<hr/>				
	20,576.00	12,732.50	1,064.75	13,797.25	6,778.75



**"I was hungry and you fed me..."
-Matthew 25:35**

MINUTES

Upper Room Mission Annual General Meeting - May 13, 2019 [2019-5]

- 1- Call to order – by Chair at 5:30 PM
- 2- Before we begin we acknowledge that we are gathered in the northern part of the unceded Okanagan First Nation territory - many descendants of the Suqnaquinx (Suk-anok-can) still live here."
- 3- Prayer – Joe
- 4- Quorum – Dustin advised we have a quorum present
- 5- Voting Members Present – Sandra, Harold, Joe, Maggie, Randel, Dustin, Linda Y, Cherie H, Cera & Nicole
- 6- 2018 AGM minutes – MOTION to Approve Harold\Randel CARRIED
- 7- Bd of Directors Ann. Report - verbal by Chair – MOTION to receive Maggie/Joe CARRIED
 - a- Coldest Night – to be replaced with another fundraiser for next year
 - b- Nicole has been hired as our new Executive Director -
 - c- Alpha course was well received
 - d- Dustin has "retired" from Board service - after serving 2 terms of 3 years each
- 8- Financial Report – Joe H highlighted MOTION to adopt Dustin\Patty CARRIED
 - a. Income was down,
 - b. Expenses up – wages increased due to minimum wage...
 - c. BDO Engagement Review reports our procedures are in order
 - d. The Boutique is our main source of revenue
 - e. High ICBC vehicle expense has now been lowered
- 9- Director Nominations – The Board nominated Trevor Cairns of A1 Bus
- 10- Election - no additional nominations - Chair declared him elected by ACCLAMATION.
- 11- Other Business – no matters were raised
- 12- MOTION to Adjourn Dustin\Randel CARRIED 5:55 PM

THANKS TO THOSE ATTENDING

Respectfully Submitted – Harold young, Sec.

The Board then held the normal organizational meeting.



STATEMENT OF DIRECTORS AND REGISTERED OFFICE

BC Society • Societies Act

CERTIFIED COPY
Of a document filed with the
Province of British Columbia
Registrar of Companies

Albert
CAROL PREST

NAME OF SOCIETY: VERNON UPPER ROOM MISSION SOCIETY

Incorporation Number: S0015964
Business Number: 10816 3320 BC0001
Filed Date and Time: May 28, 2019 02:48 PM Pacific Time

REGISTERED OFFICE ADDRESS INFORMATION

Delivery Address:
3403 27TH AVE
VERNON BC V1T 1S2

Mailing Address:
3403 27TH AVE
VERNON BC V1T 1S2

DIRECTOR INFORMATION

Last Name, First Name Middle Name:
CAIRNS, TREVOR

Delivery Address:
[REDACTED]

Last Name, First Name Middle Name:
ERBACKER, RANDEL

Delivery Address:
[REDACTED]

Last Name, First Name Middle Name:
HOUTMAN, JOE

Delivery Address:
[REDACTED]

Last Name, First Name Middle Name:
METZ, MAGGIE

Delivery Address:
[REDACTED]



STATEMENT OF DIRECTORS AND REGISTERED OFFICE

BC Society - Societies Act

Last Name, First Name Middle Name:

SIMAO, SANDRA

Delivery Address:

[REDACTED]

Last Name, First Name Middle Name:

YOUNG, HAROLD

Delivery Address:

[REDACTED]



The Corporation of the City of Vernon

COUNCIL DISCRETIONARY GRANT APPLICATION FORM



IMPORTANT: The deadline for Council Discretionary Grant Applications are semi-annual being April 30 and October 31 each calendar year.

Applications will only be accepted during the intake periods of April 1 - April 30 and October 1 to October 31. Applications must be submitted to the Director of Financial Services no later than 4:00pm on the application deadline (April 30th and October 31st), if City Hall is closed that day, on the next working day that City Hall is open.

Applicants may run the risk of grant funding being depleted if waiting to apply until the October intake deadline.

If grant applications are received after the cut off periods they will be returned to the applicant and must be submitted at the next intake period.

Please note: Incomplete applications will not be considered

ORGANIZATION INFORMATION

NAME OF ORGANIZATION APPLYING FOR COUNCIL DISCRETIONARY GRANT:	Vernon Concert Band Society
CONTACT PERSON:	Shirley Blatchford
ORGANIZATION MAILING ADDRESS:	[REDACTED]
BUSINESS PHONE:	[REDACTED]
EMAIL ADDRESS:	[REDACTED]
REGISTERED NON PROFIT SOCIETY INCORPORATION NUMBER (required):	50054339

"Personal information contained on this form is collected under the Freedom of Information and Protection of Privacy Act and will be used only for the purposes of responding to your request".

City Hall Address: 3400 30th Street, Vernon BC, V1T 5E6
Inquiries: 250-545-1361
Web: www.vernon.ca



The Corporation of the City of Vernon

COUNCIL DISCRETIONARY GRANT APPLICATION FORM

ORGANIZATION GOALS, OBJECTIVES AND ACTIVITIES:

The goal of the Vernon Concert Band Society is to provide a venue for people of all ages and abilities to get together and play in a concert band and to share that love of music with others by playing concerts and providing music for community events.

SERVICE PROVIDED TO THE COMMUNITY:

We provide music for public events. Some examples are: Remembrance Day ceremonies, City of Vernon Bike to Work Week, City of Vernon celebration of first air mail delivery, opening and closing ceremonies for the 2012 Winter Games and Polson Park events such as the Womens Auxiliary Garden Fair, Vernon Jubilee Hospital Hip Hip Hooray and Vernon Lions Club Ducks for Dogs fund raisers.

A PROFILE AND HISTORY OF THE ORGANIZATION AND ITS ACCOMPLISHMENTS:

See attached profile.

PLEASE IDENTIFY THE STEPS YOUR ORGANIZATION HAS TAKEN TO ACQUIRE GRANTS FROM OTHER SOURCES:

We will apply for the BC Gaming grant. This last year we were able to obtain \$2000 that went towards our operating expenses.

City Hall Address: 3400 30th Street, Vernon BC, V1T 5E6
Inquiries: 250-545-1361
Web: www.vernon.ca



The Corporation of the City of Vernon

COUNCIL DISCRETIONARY GRANT APPLICATION FORM

GRANT REQUEST

(You may wish to provide attachments, please note below where these items can be found.)

AMOUNT OF REQUEST:

\$800

IN-KIND SERVICES: (please describe and include cost)

n/a

PURPOSE OF GRANT AND PROPOSED ALLOCATION OF FUNDS:

To cover some of the operating expenses that allow the band to practice and perform. For example, we require liability insurance to rent space to practice at Seaton School as well as to perform concerts at such venues as Polson Park.

BENEFITS TO COMMUNITY RESULTING FROM GRANT OR CITY GOALS AND OBJECTIVES THAT WILL BE MET, IF THE GRANT IS APPROVED:

The Vernon Community Band can continue to provide music for the City of Vernon and other community events in the Greater Vernon area.

DEGREE OF COMMUNITY FINANCIAL SUPPORT OR SPONSORSHIP:

Membership dues: \$2350
Gaming Grant: \$2000
Personal donations: \$1837
Fundraising: \$1321
Performances: \$1000

There is no sponsorship received.

City Hall Address: 3400 30th Street, Vernon BC, V1T 5E6
Inquiries: 250-545-1361
Web: www.vernon.ca



The Corporation of the City of Vernon

COUNCIL DISCRETIONARY GRANT APPLICATION FORM

DEGREE OF DEMONSTRATED ECONOMIC DEVELOPMENT, ENVIRONMENTAL STEWARDSHIP OR SOCIAL BENEFIT THAT MAY BE GENERATED BY THE AWARD OF A COUNCIL DISCRETIONARY GRANT:

A community music band such as The Vernon Community Band, provides a social benefit to the community and for the musicians within the band. Music has been shown to be beneficial for health (emotional and physical) both for those that listen and those that play. By providing funding, the band can continue to practice weekly and then provide music for the community.

GRANT QUALIFICATION CHECKLIST (please check all that apply):

- Community Based
- Providing a service which is not provided by any other group or organization within the City or which is provided for in another municipality and used by residents
- Must only submit one application per calendar year
- Grant request is not to cover retroactive funding or to cover a deficit

Note: Organizations do not qualify for the discretionary grant program if they are in receipt of regional funding or are receiving grants or other assistance from the City of Vernon.

GRANT REQUIREMENTS (please attach to your grant application):

- Most Recent Set of Financial Statements
- Minutes of Most Recent Annual General Meeting
- List of Members of the Executive (including positions held, address and contact numbers)

In the case of newly formed groups, a budget and information regarding the organization purpose including list of Board of Directors will be sufficient.

October 7, 2019

Date



Signature

City Hall Address: 3400 30th Street, Vernon BC, V1T 5E6
Inquiries: 250-545-1361
Web: www.vernon.ca

History, Profile and Accomplishments : Vernon Community Band

The Vernon Community Band started as the Second Wind Community Band in the mid-late 1980's. Originally it was composed of a few musicians wanting to learn a new instrument or to brush off that high school instrument and return to band. As a small group, the band played around the various retirement homes such as Vernon Restholm, Canterbury Court, Carrington Place, Noric House, Gateby, and Orchard Valley, for the outdoor Remembrance Day ceremonies at Cenotaph Park and for the Winter Carnival.

Over the years, the band has increased in size to its current 30 member status and includes adults of all ages with a variety of abilities including some from professional backgrounds. For several years, the band combined with a credit course "Instrumental Music – Concert Band 11 and 12" from Vernon Senior Secondary School in which the high school students could help develop their musical skills and be mentored by accomplished adult players. Currently there are 2 students from the Seaton Secondary band that are helping out by playing instruments not covered by members. Under the direction of Toni Rose, the band has continued to grow and increase the level of music performed.

The Vernon Community band currently meets once a week during the school year at Seaton Secondary School to practice and prepare for concerts. We have provided music for community events such as:

- City of Vernon Remembrance Day ceremonies.
- The City of Vernon Bike to Work week.
- Vernon Jubilee Hospital Ladies Auxiliary Garden Fair.
- Christmas and Spring concerts at Vernon Senior Secondary School with the VSS high school band.
- Hip Hip Hooray fundraiser for the orthopedic department at Vernon Jubilee Hospital.
- The opening and closing ceremonies for the 2012 B.C Winter Games.
- 2019 Ducks for Dogs event held in Poson Park by the Vernon Lions Club.

The Vernon Community band has combined with other bands in performances in and around Vernon. We have played with the Kalamalka Highlanders Pipe band, the Mark Rose Swing Band, commuted to Kamloops to play on stage for a street fair and hosted the Dawson Creek community band. In 2005, the Vernon band combined with the Kelowna City band and the Salmon Arm Community band to celebrate Shakespeare's birthday with a performance at the Vernon Performing Arts centre. All proceeds were donated to the Stephen Lewis Foundation to help with the AIDS/HIV epidemic in Africa. In 2017 and 2018 we participated in the Okanagan Military Tattoo at Kal Tire Place.

Vernon Community band competed in our very first competition in 2015 at the Kiwanis Music festival in Lake Country. Not only did we win our division, we obtained the top overall score of 92%. To hone our musical skills, we attended a non-adjudicated Salmon Arm music festival in 2016 and in 2017, had Rosemary Thompson of the Okanagan Symphony attend a practice session.



2018 BC SOCIETY ANNUAL REPORT

BC Society • Societies Act

NAME OF SOCIETY: **VERNON CONCERT BAND SOCIETY**
Incorporation Number: S0054339
Business Number: 83219 3221 BC0001
Filed Date and Time: January 28, 2019 02:53 PM Pacific Time
Annual General Meeting (AGM) Date: December 12, 2018

REGISTERED OFFICE ADDRESS INFORMATION

Delivery Address: [Redacted] Mailing Address: [Redacted]

DIRECTOR INFORMATION AS OF December 12, 2018

Last Name, First Name Middle Name:
BAUML, CORRIE

Delivery Address:
[Redacted]

Last Name, First Name Middle Name:
BEXTON, STEWART

Delivery Address:
[Redacted]

Last Name, First Name Middle Name:
BLATCHFORD, SHIRLEY

Delivery Address:
[Redacted]

Last Name, First Name Middle Name:
KANESTER, ANNE-MARIE

Delivery Address:
[Redacted]

Last Name, First Name Middle Name:

LISSAU, JULIA

Delivery Address:



Last Name, First Name Middle Name:

REIM, DAVID

Delivery Address:



Last Name, First Name Middle Name:

ROOKS, SUE

Delivery Address:



Last Name, First Name Middle Name:

SPEARING, DIANE

Delivery Address:



Last Name, First Name Middle Name:

WITT, TJANA

Delivery Address:



CERTIFICATION

I, Corrie Bauml, certify that I have relevant knowledge of the society, and that I am authorized to make this filing.



STATEMENT OF DIRECTORS AND REGISTERED OFFICE

BC Society • Societies Act

CERTIFIED COPY
Of a document filed with the
Province of British Columbia
Registrar of Companies

Albert

CAROL PREST

NAME OF SOCIETY: VERNON CONCERT BAND SOCIETY

Incorporation Number: S0054339
Business Number: 83219 3221 BC0001
Filed Date and Time: January 28, 2019 02:53 PM Pacific Time

REGISTERED OFFICE ADDRESS INFORMATION

Delivery Address:

Mailing Address:



DIRECTOR INFORMATION

Last Name, First Name Middle Name:

BAUML, CORRIE

Delivery Address:



Last Name, First Name Middle Name:

BEXTON, STEWART

Delivery Address:



Last Name, First Name Middle Name:

BLATCHFORD, SHIRLEY

Delivery Address:



Last Name, First Name Middle Name:

KANESTER, ANNE-MARIE

Delivery Address:





STATEMENT OF DIRECTORS AND REGISTERED OFFICE

BC Society • Societies Act

Last Name, First Name Middle Name:

LISSAU, JULIA

Delivery Address:



Last Name, First Name Middle Name:

REIM, DAVID

Delivery Address:



Last Name, First Name Middle Name:

ROOKS, SUE

Delivery Address:



Last Name, First Name Middle Name:

SPEARING, DIANE

Delivery Address:



Last Name, First Name Middle Name:

WITT, TJANA

Delivery Address:

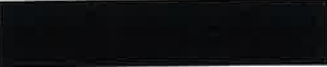

**Financial Statement
Vernon Community Band Society
Statement of Revenues and Expenses
for the year ended June 30, 2019**

Revenues	General Fund	Gaming Fund	Total
• Community Gaming Grant	-	\$2,000.00	\$2,000.00
• Membership fees	\$2,350.00	-	\$2,350.00
• Interest and other	\$54.88	-	\$54.88
• Fundraiser	\$1,321.00	-	\$1,321.00
• Donations	\$1,837.25	-	\$1,837.25
• Performances	\$1,000.00	-	\$1,000.00
	\$6,563.13	\$2,000.00	\$8,563.13
EXPENSES			
• Insurances (Note 1)	\$713.00	\$39.00	\$752.00
• Depreciation (Drum Kit) (Note 2)	\$67.28	-	\$67.28
• Rehearsal and venue rentals	\$1,325.76	\$1,500.00	\$2,825.76
• Honorariums	\$1,150.00	\$700.00	\$2,350.00
• BC Registry Services	\$55.00	-	\$55.00
TOTALS	\$3,350.04	\$2,239.00	\$6,050.04
Excess of Revenue over Expenses	\$3,213.09	-\$239.00	\$2,513.09

Approved by

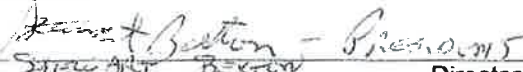
 Stewart Berton - President
 Director

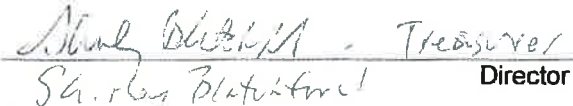
 Sheryl Blumenthal - Treasurer
 Director

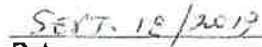
 Date

 Date

Note 1: Prepaid insurance \$713 from fiscal 2018 + \$39 in 2019

Note 2: Drum kit straight line depreciation over 20 years, purchased 2018 fiscal (\$67.28/year)

**Vernon Community Band Association
Balance Sheet
As at June 30, 2019**

	General Fund	Gaming Fund	Total
Current Assets			
Cash in Bank	\$2,591.54	\$2,000.12	\$4,591.66
Prepaid Expenses – Insurance	\$0.00	\$749.00	\$749.00
	<u>\$2,591.54</u>	<u>\$2,749.12</u>	<u>\$5,340.66</u>
Capital Assets			
Timpani (x2)	\$6,176.80	-	\$6,176.80
Drum Kit <small>Note 1</small>	\$1,278.22	-	\$1,278.22
	<u>\$7,455.02</u>	<u>-</u>	<u>\$7,455.02</u>
Total Assets	<u>\$10,046.56</u>	<u>\$2,749.12</u>	<u>\$12,795.68</u>
Current Liabilities			
Accounts Payable and Accruals	-	\$1,488.00	\$1,488.00
Instrument Depreciation (Drum Kit) <small>Note 2</small>	\$67.28	-	\$67.28
	<u>\$67.28</u>	<u>\$1,488.00</u>	<u>\$1,555.28</u>
Fund balances			
Externally Restricted	\$0.00	\$0.00	\$0.00
Internally Restricted -for purchase of instruments (bells, congas, timpani, baritone saxophone) <small>Note 3</small>	\$1,500.00	\$0.00	\$1,500.00
Unrestricted	\$8,479.28	\$1,261.12	\$9,740.40
	<u>\$9,979.28</u>	<u>\$1,261.12</u>	<u>\$11,240.40</u>
Total Liabilities and fund balances	<u>\$10,046.56</u>	<u>\$2,749.12</u>	<u>\$12,795.68</u>

Approved by

Stewart Deffen - PRESIDENT
STEWART DEFFEN
Director

Sept 18/2019
Date

Shirley Blakford Treasurer
Shirley Blakford
Director

Sept 18/19
Date

Note 1: Drum kit less accumulated depreciation (year1)
 Note 2: Percussion depreciation calculated straight line over 20 years.
 Note 3: Directors meeting June 19, 2019 – Restricted \$1500 for instruments

**Operating Budget
Vernon Community Band Society
Projected Revenues and Expenses
for the year ending June 30, 2020**

Revenues

	General Fund	Gaming Fund	Total
City of Vernon Discretionary Grant	\$500.00		\$500.00
British Columbia Community Gaming Grant		\$3,000.00	\$3,000.00
Membership fees	\$3,000.00		\$3,000.00
Interest and other	\$100.00		\$100.00
Donations	\$500.00		\$500.00
Performances	\$500.00		\$500.00
Fundraising	\$1,500.00		\$1,500.00
Inkind – Labour	\$1,500.00		\$1,500.00
Inkind – Materials	\$100.00		\$100.00
Inkind – Equipment Storage	\$1,200.00		\$1,200.00
Sub Totals – Revenues	\$8,900.00	\$3,000.00	\$11,900.00

Expenses

	General Fund	Gaming Fund	Total
Advertising	\$250.00		\$250.00
Legal	\$900.00		\$900.00
Bank charges/ Admin	\$60.00		\$60.00
Insurances	\$750.00		\$750.00
Music	\$1,000.00		\$1,000.00
Contingency fund	\$500.00		\$500.00
Rent, Venue rentals	\$1,000.00	\$2,000.00	\$3,000.00
Honorarium – Band Conductor	\$1,000.00	\$1,000.00	\$2,000.00
Honorarium – Guest Conductor	\$300.00		\$300.00
BC Registry Services	\$40.00		\$40.00
BC Band Association fees	\$50.00		\$50.00
Transportation	\$150.00		\$150.00
Repairs	\$100.00		\$100.00
Inkind – Labour	\$1,500.00		\$1,500.00
Inkind – Materials	\$100.00		\$100.00
Inkind – Equipment Storage	\$1,200.00		\$1,200.00
Sub Totals – Expenses	\$8,900.00	\$3,000.00	\$11,900.00

Excess of revenues over expenses	\$0.00	\$0.00	\$0.00
---	---------------	---------------	---------------

*Shirley Blackford
Vernon Community Band Society
06/22/20*

*Shirley Blackford
Vernon Community Band Society
06/22/20*

**Capital Budget
 Vernon Community Band Society
 Projected Revenues and Expenses
 for the year ending June 30, 2020 and 5 year Plan**

	<u>2020</u>	<u>5 year</u>
REVENUES		
Restricted revenue/capital savings from 2019	\$1,500.00	
Fundraising	\$500.00	\$2,000.00
City of Vernon Discretionary Grant	\$500.00	
Performances	\$500.00	\$2,000.00
SUB TOTALS – Revenues	<u>\$3,000.00</u>	<u>\$4,000.00</u>
 EXPENSES		
Bells	\$800.00	
Tympani Drum		\$4,000.00
Congas (pair)		\$1,800.00
Baritone Saxophone (used)		\$6,000.00
SUB TOTALS – Expenses	<u>\$800.00</u>	<u>\$11,800.00</u>
 EXCESS REVENUE OVER EXPENSES	 \$2,200.00	 -\$5,600.00

[Faint signature] *SECRET* *June 26/2019*

Stirley Blanton
Stirley Blanton - Treasurer *Jun 26/19*

VERNON CONCERT BAND SOCIETY
ANNUAL GENERAL MEETING
December 12, 2018 at 7:00 PM
Seaton Secondary School
MINUTES

CALL TO ORDER: **7 PM**

CHAIR: Meeting chaired by President, S. Bexton

CONFIRMATION OF QUORUM: - 22 member present, (sign in sheet attached).
- a quorum of members was present

ADOPTION OF AGENDA : - Move/ P. Wagner, Seconder/ S. Bexton **Carried**

ADOPTION OF MINUTES of the 2017 AGM held on November 15, 2017:

-errors or omissions **None**

MOTION: To approve the Minutes as circulated. M/ A. Kanester S/ J. Lissau **Carried**

TREASURER'S REPORT: **-Corrie Bauml, Treasurer (2018-19 Budget attached)**

Corrie Bauml, Treasurer, presented and explained the 2018-19 Budget as previously approved by Directors. Throughout the year funds were acquired from a successful fundraiser concert and silent auction, City of Vernon Grant, BC Gaming Grant, payments for playing at civic and community concerts, and donations from band members.

It is recommended that we keep our annual membership fees at \$100 per person.

A portion of the money that was set aside in our Restricted Capital Savings Fund was used to purchase a drum kit. More percussion equipment will be purchased as our Capital Savings Fund grows and more funds become available.

Due to the new mandatory insurance requirements for the rental of any rehearsal space, this year was the first time insurance was purchased, thus increasing our operating costs.

it is recommended that we continue to seek out donations, municipal support as well as government grants.

MOTION: To approve Treasurer's Report as presented. M/ C. Bauml, S/ D. Reim. **Carried**

MUSIC DIRECTOR'S REPORT: -Toni Rose, Conductor

Toni Rose gave an oral report highlighting our activities and successes this year. She thanked donors and the Directors. Our goals are to purchase new music, update the inventory of our music, expand on the number of performances, and encourage more players to join the band.

MOTION: To approve Music Director's report as presented. M/ T Rose, S/ S Rook **Carried**

PRESIDENT'S REPORT -Stewart Bexton, President

Stew Bexton thanked the Directors and commented on the activities and successes of our busy year. He discussed some of the challenges changing rehearsal venues. Fundraising and purchasing more percussion instruments will remain our primary goal next year.

MOTION: To approve President's report as presented. M/ S. Bexton, S/ A. Kanester **Carried**

ELECTION OF DIRECTORS:

Outgoing President thanked the Directors and explained that Directors are elected for a one year term. Members and outgoing Directors may be nominated for a one year term for the coming year. The following were nominated.

- | | |
|---------------------|----------------|
| Shirley Blatchford | David Reim |
| Sue Rook | Diane Spearing |
| Corrie Bauml | Tjana Witt |
| Julia Lissau | Stewart Bexton |
| Anne-Marie Kanester | |

Chair asked for further nominations from the floor three times. No further nominations were proposed.

Motion to close nominations. M/ J Paas S/ S Rook **Carried**

Motion: That the 9 nominees be elected as Directors for the next year.

M/ J. Nielsen S/ L. Leonard **Carried**

ADJOURNMENT: Meeting adjourned at 7:30

Recording Secretary: Anne-Marie Kanester



The Corporation of the City of Vernon COUNCIL DISCRETIONARY GRANT APPLICATION FORM



IMPORTANT: The deadline for Council Discretionary Grant Applications are semi-annual being April 30 and October 31 each calendar year.

Applications will only be accepted during the intake periods of April 1 - April 30 and October 1 to October 31. Applications must be submitted to the Director of Financial Services no later than 4:00pm on the application deadline (April 30th and October 31st), if City Hall is closed that day, on the next working day that City Hall is open.

Applicants may run the risk of grant funding being depleted if waiting to apply until the October intake deadline.

If grant applications are received after the cut off periods they will be returned to the applicant and must be submitted at the next intake period.

Please note: Incomplete applications will not be considered

ORGANIZATION INFORMATION

NAME OF ORGANIZATION APPLYING FOR COUNCIL DISCRETIONARY GRANT:	Vernon Homeless Outreach Team Association
CONTACT PERSON:	Jeanne Arcand
ORGANIZATION MAILING ADDRESS:	[REDACTED]
BUSINESS PHONE:	[REDACTED]
EMAIL ADDRESS:	Homelessoutreachteamvernon@gmail.com
REGISTERED NON PROFIT SOCIETY INCORPORATION NUMBER (required):	50071551

"Personal information contained on this form is collected under the *Freedom of Information and Protection of Privacy Act* and will be used only for the purposes of responding to your request".



The Corporation of the City of Vernon COUNCIL DISCRETIONARY GRANT APPLICATION FORM

ORGANIZATION GOALS, OBJECTIVES AND ACTIVITIES:

Our main goal is to offer compassion to those living on the streets in Vernon BC and to let them know that someone does care.

Another goal is to provide essentials like warm blankets, clothing, toiletries and harm reduction to anyone living on the streets in Vernon.

SERVICE PROVIDED TO THE COMMUNITY:

Our service provides our homeless population of Vernon support for living on the streets. We offer compassion and care without judgement to those who for whatever reason ended up homeless.

A PROFILE AND HISTORY OF THE ORGANIZATION AND ITS ACCOMPLISHMENTS:

We have been providing outreach on our own for about a year. There are 5 of us that go out regularly on Thursday nights. We have funded this from our own funds and donations from our friends and family so far. We supply food- (yogurt, bananas, fresh homemade baking, biscuits, bottled water, hot chocolate in the winter and freezies in the summer. Toiletries for both men and women- bandaides, wet wipes, kleenex, toothbrushes and paste, hair ties, brushes, combs, shampoo and conditioner, chapstick, pads/tampons for the ladies, and condoms and pregnancy tests. We also supply warm clothing, socks, jackets, boots, scarves, hats, gloves and blankets etc for the colder weather. We are all trained to administer Narcan and some of us have actually had to use our training while out on the street. We also give out Narcan kits and harm reduction kits.

Our first official event was at the Overdose Awareness Day where we had a table set up to introduce our team to Vernon.

We organized a fund raiser to get one of our men help with vet bill for his little dog. We have purchased reading glasses for a few people. We do take requests for small items and if able we will try to get them what they need. We are very passionate about what we do. We would like to go out more nights, but until we secure some funding, this just isn't feasible.

PLEASE IDENTIFY THE STEPS YOUR ORGANIZATION HAS TAKEN TO ACQUIRE GRANTS FROM OTHER SOURCES:

We have applied for Walmart Community Grant of \$1000. We have a raffle starting Oct 26th. Because we are not a Registered Charity yet, we are limited to what we can apply for. Application for Registered Charity has been sent but it may take up to 10 months for approval. We are new at this so we are looking into grants we can apply for.

City Hall Address: 3400 30th Street, Vernon BC, V1T 5E6

Inquiries: 250-545-1361

Web: www.vernon.ca



The Corporation of the City of Vernon

COUNCIL DISCRETIONARY GRANT APPLICATION FORM

GRANT REQUEST

(You may wish to provide attachments, please note below where these items can be found.)

AMOUNT OF REQUEST:

\$2500

IN-KIND SERVICES: (please describe and include cost)

We receive all of our clothing, blankets, boots, gloves, scarves, etc. from donations from various people. This keeps our costs down so we can purchase the supplies we carry.

PURPOSE OF GRANT AND PROPOSED ALLOCATION OF FUNDS:

We would use the funds for supplying our carts with food and essentials.

BENEFITS TO COMMUNITY RESULTING FROM GRANT OR CITY GOALS AND OBJECTIVES THAT WILL BE MET, IF THE GRANT IS APPROVED:

This grant would mean we could continue to offer our outreach to the homeless population in Vernon for another year.

DEGREE OF COMMUNITY FINANCIAL SUPPORT OR SPONSORSHIP:

All of our funding so far has come from community members. We are continuing our fundraising efforts with a few community groups. The Girl Guides and Pathfinders have been a wonderful support for us. Currently the Lumby Girl Guides and Pathfinders are doing a sock, mitts, scarves and jacket drive for us. Last year they supplied us with Christmas goodie bags for about 30 people. The Medicine Shoppe Pharmacy has recently offered their support with pharmacy related items that we may need. We also work with Cammy LaFleur Street Clinic who provides us with harm reduction and Narcan.

City Hall Address: 3400 30th Street, Vernon BC, V1T 5E6

Inquiries: 250-545-1361

Web: www.vernon.ca



The Corporation of the City of Vernon

COUNCIL DISCRETIONARY GRANT APPLICATION FORM

DEGREE OF DEMONSTRATED ECONOMIC DEVELOPMENT, ENVIRONMENTAL STEWARDSHIP OR SOCIAL BENEFIT THAT MAY BE GENERATED BY THE AWARD OF A COUNCIL DISCRETIONARY GRANT:

Our outreach program provides the homeless community with a little bit of compassion, something that these people rarely see. We try to keep tabs on people, to make sure they are safe and warm. We refer new people to the Mission or to services that are available to them. We work together with other community groups to help let these people know that they are not alone and we do what we can to make their nights a little warmer, less hungry and safe.

GRANT QUALIFICATION CHECKLIST (please check all that apply):

- Community Based
- Providing a service which is not provided by any other group or organization within the City or which is provided for in another municipality and used by residents
- Must only submit one application per calendar year
- Grant request is not to cover retroactive funding or to cover a deficit

Note: Organizations do not qualify for the discretionary grant program if they are in receipt of regional funding or are receiving grants or other assistance from the City of Vernon.

GRANT REQUIREMENTS (please attach to your grant application):

- Most Recent Set of Financial Statements
- Minutes of Most Recent Annual General Meeting
- List of Members of the Executive (including positions held, address and contact numbers)

In the case of newly formed groups, a budget and information regarding the organization purpose including list of Board of Directors will be sufficient.

Oct 1/19

Date

Jeanne Arcand

Signature

**Vernon Homeless Outreach Team Association
2019-2020 Annual Budget**

INCOME	
Walmart Donation	\$1,000.00
Raffle proceeds	\$2,000.00
Misc. Donations	\$500.00
City of Vernon	\$2,500.00
Website/Facebook Donations	\$500.00
TOTAL	\$6,500.00
EXPENSES	
Website	\$140.00
Bank Charges	\$80.00
Supplies	\$3,755.00
Food	\$1,600.00
Bottled Water	\$500.00
Advertising/Brochures	\$200.00
Insurance	\$160.00
licenses/Fees	\$25.00
Annual Report Filing	\$40.00
TOTAL	\$6,500.00

g

GENERAL MEETING: VERNON HOMELESS OUTREACH TEAM ASSEMBLY 09

Thursday, June 27th, 2019, 5pm- Kal Hotel

IN ATTENDANCE:

Jeanne Arcand

Anita Clifford

Robyn Thurston

Laura Stamnes Heggenstaller

Jennifer Monteith

Treasurer's report: We currently have \$1083.06 in cash

Appointment/election of officers:

President- B. Jeanne Arcand

Vice-President- Anita Clifford

Secretary/Treasurer- Robyn Thurston

We will have Jeanne and Anita as signors. Each one can sign a check and have access to online banking. We will make an apt at Valley First Credit Union in Vernon and open a proper bank account

Meeting adjourned 6:30pm

Minutes approved by:



Jeanne Arcand



Anita Clifford



STATEMENT OF DIRECTORS AND REGISTERED OFFICE

BC Society • Societies Act

CERTIFIED COPY
Of a document filed with the
Province of British Columbia
Registrar of Companies

CAROL PREST

NAME OF SOCIETY: **VERNON HOMELESS OUTREACH TEAM ASSOCIATION**

Incorporation Number: S0071551
Business Number: 78576 4879 BC0001
Filed Date and Time: June 23, 2019 12:56 PM Pacific Time

REGISTERED OFFICE ADDRESS INFORMATION

Delivery Address:

Mailing Address:

[Redacted address information]

DIRECTOR INFORMATION

Last Name, First Name Middle Name:

ARCAND, BETTY (JEANNE)

[Redacted name information]

Delivery Address:

[Redacted address information]

Last Name, First Name Middle Name:

CLIFFORD, ANITA

[Redacted name information]

Delivery Address:

[Redacted address information]

Last Name, First Name Middle Name:

THURSTON, ROBYN JEAN

[Redacted name information]

Delivery Address:

[Redacted address information]



BRITISH
COLUMBIA

Number: S0071551

Societies Act
CERTIFICATE OF INCORPORATION

VERNON HOMELESS OUTREACH TEAM ASSOCIATION

I Hereby Certify that ~

VERNON HOMELESS OUTREACH TEAM ASSOCIATION was incorporated under the
Societies Act on June 23, 2019 at 12:56 PM Pacific Time.

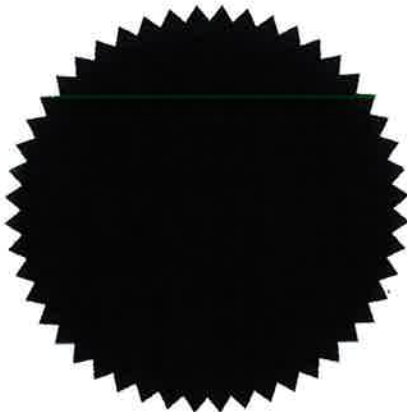

*Issued under my hand at
Victoria, British Columbia*

Albert

CAROL PREST

REGISTRAR OF COMPANIES
PROVINCE OF BRITISH COLUMBIA
CANADA

'They trust us': New homeless outreach team formed in Vernon

The group offers food, clothing and supplies to people in need

Dominika Lirette · CBC News · Posted: Aug 27, 2019 7:02 PM PT | Last Updated: August 27



Members of the Vernon Homeless Outreach Team Association hand out supplies to people in need one night a week. (Submitted by Jeanne Arcand)

A group of volunteers has banded together in the north Okanagan to form the Vernon Homeless Outreach Team Association. Every Thursday night, they pull carts around the city carrying food, hygiene products, Narcan and other supplies, offering assistance to people who are homeless.

"[We] just let people know that we're out there and we care about them," said Jeanne Arcand, the President of the association. The team has been working together for the past year but only recently officially registered as a society.

"So, we decided to form our own group that serves both the men and the women."

there's a lot of men out there," she said.

"I loved it, except for we found it very hard because H.O.P.E. is for women, so, you know,

and exploited men in Kalamazoo and Vernon.

Arcand used to be a member of another outreach organization, H.O.P.E., which helps homeless

winter. (Submitted by Jasmine Arcand)

Team members Anita Clifford and Jeanne Arcand hand out supplies in downtown Vernon in the

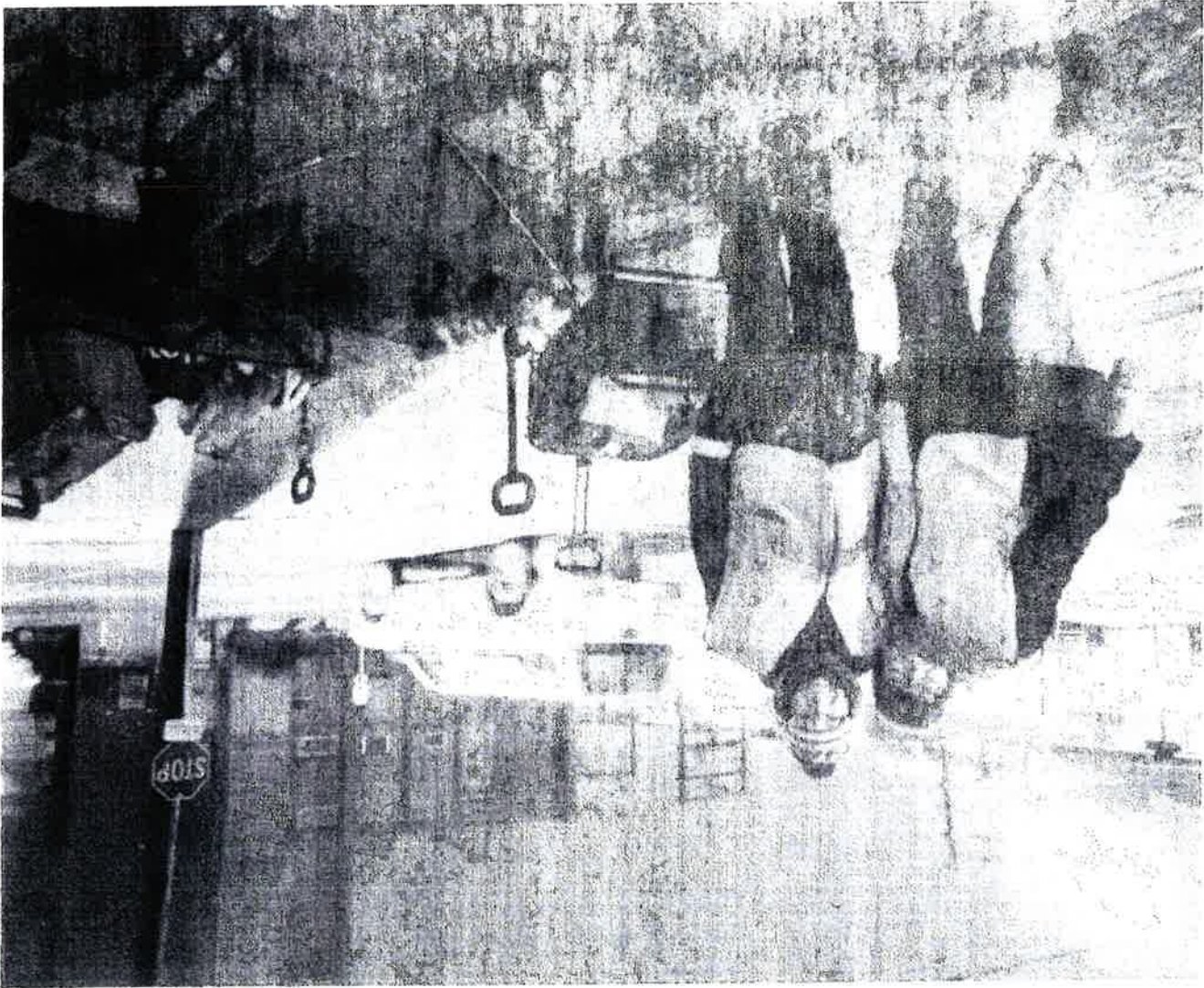

Community reception

So far, the reception they have received in the community has been both "good and bad," Arcand told *Daybreak South* host Chris Walker. Homelessness and addiction have been a point of contention in Vernon. Plans to open an overdose prevention site this summer were halted in April to allow time for further consultation, and in June, more than 40 people attended an emotional town hall meeting, sharing their frustrations in relation to crime, homelessness and drug use in the downtown core.

- 'Our town has turned into a hellhole': Emotions run high at Vernon town hall on downtown issues

Last week, Vernon city council directed staff to prepare a zoning bylaw amendment with additional development regulations for future emergency shelters built in the city. Some of the requested development regulations include setbacks to reduce congregation on the sidewalk, exterior lighting and designated onsite smoking areas.

"We never know what we're going to get," said Arcand. "We get someone coming up and you know, handing us a \$100 bill, or we get someone that's ranting and raving about how we're enabling [the homeless]."

- Interior Health puts Vernon overdose prevention site on hold for further consultation

Many of the people the group helps have addiction issues, but there are also lots who don't, she added. The group has formed strong relationships with many of the people they assist, but the crowd has changed over the past year, due to the opening of the new emergency shelter, Our Place, funded by B.C. Housing.

"We had about 46 of our homeless people go into Our Place housing. So that's good," said Arcand. "So now, we have a whole new crew that we're getting to know. They're very nice to us. You know, they trust us. They come running when they see us, so that we're welcomed."

With files from Daybreak South

Community reception

So far, the reception they have received in the community has been both "good and bad," Arcand told Daybreak South host Chris Walker. Homelessness and addiction have been a point of contention in Vernon. Plans to open an overdose prevention site this summer were halted in April to allow time for further consultation, and in June, more than 40 people attended an emotional town hall meeting, sharing their frustrations in relation to crime, homelessness and drug use in the downtown core.

- 'Our town has turned into a hellhole': Emotions run high at Vernon town hall on emergency issues

Last week, Vernon city council directed staff to prepare a zoning bylaw amendment with additional development regulations for future emergency shelters built in the city. Some of the requested development regulations include setbacks to reduce congregation on the sidewalk, exterior lighting and designated onsite smoking areas.

"We never know what we're going to get," said Arcand. "We get someone coming up and you know, handing us a \$100 bill, or we get someone that's ranting and raving about how we're enabling [the homeless]."

- Interior Health puts Vernon overdose prevention site on hold for further consultation

Many of the people the group helps have addiction issues, but there are also lots who don't, she added. The group has formed strong relationships with many of the people they assist, but the crowd has changed over the past year, due to the opening of the new emergency shelter, Our Place, funded by B.C. Housing.

"We had about 46 of our homeless people go into Our Place housing. So that's good," said Arcand. "So now, we have a whole new crew that we're getting to know. They're very nice to us. You know, they trust us. They come running when they see us, so that we're welcomed."

With files from Daybreak South

VERNON MORNING STAR
NEWSPAPER ARTICLE

outreach team

The Vernon Homeless Outreach Team makes its first formal appearance Aug. 28 at Upper Room Mission.

- BRENDAN NHYKOBA
- Aug. 24, 2019 4:00 p.m.
- LOCAL NEWS
- NEWS

Vernon has a new team going to bat for the city's homeless population.

Introducing the Vernon Homeless Outreach Team, a group of eight locals who formerly worked with HOPE Outreach – a late-night outreach for homeless and exploited women in the downtown cores of Kelowna and Vernon.

The group registered as a non-profit society after splitting off from HOPE about a year ago, when they decided it was too difficult to turn down the men who ask for help on their night time walks.

"HOPE is awesome, but we just felt that we needed to service the men too. They're cold and hungry just like the women are," said Outreach Team member Jeanne Arcand.

Local News: Services provided at night, naloxone kits save thousands of lives in B.C.

Arcand says they see about 50 people every night on their circuit around the Gateway Homeless Shelter and the People Place downtown, where they hand out food, water, clothes and hygiene products. The group has also administered naloxone – a life preserving antidote to opioid overdoses – multiple times already.

"At first we just did it on our own, supplied by our own friends and family. We did a couple Facebook fundraisers but now we've actually formed our own society, so we're going to start looking for fundraising and grants to help," Arcand said.

The outreach team will make its first formal public appearance on Wednesday, Aug. 28 at the International Overdose Awareness Day event hosted by Upper Room Mission. There, they'll be one of dozens of groups with information booths, spreading awareness of the resources that are available in the community.

About a month ago, the group started noticing new – and rougher – faces on the streets.

"Every time we go out there's more people who we haven't seen before," Arcand said. "Every day you hear people who have had their bikes and their tools stolen and their vehicles broken into. That's all part of it unfortunately.

"I was born and raised in Vernon, so to me this is just not where I grew up."

Meanwhile, the City of Vernon is working on guidelines for new emergency shelters and overdose prevention sites. Council is preparing to adjust a zoning bylaw to include more regulations on these types of structures. The added requirements will include screened outdoor storage, setbacks to reduce congregation on or near sidewalks, designated on-site smoking areas and exterior lighting. Plans are also in the works for a new community consultation process for any new shelters and overdose prevention sites, according to the Greater Vernon Chamber of Commerce.

Until those developments come to pass, the Vernon Homeless Outreach Team will have its work cut out for it. Arcand explains that dealing with the ongoing opioid crisis is relatively new territory for the group.

"We were not familiar with the drug scene. We are now obviously, but in the beginning, I think we were very naive and we've lost a few people who we've been quite close to and that's been tough," she said.

"But we're doing what we can. We all love it, and we try our best to help the people who are really struggling."

Report on the 2023 Annual Meeting of the Board of Directors, June 13, 2023

Item 10: Board of Directors, 2023 Annual Meeting, Board of Directors, 2023

HOMELESS SURVEY- 2018

- 161 people were counted as homeless in our community on Oct 18/2018
- 31% were female and 65% were male, 4% indicated transgender/other
- Average age for sleeping outside was 43 (men) and 34 (women)
- Average age in the shelters was 47 (for both men and women)
- 30% of respondents indicated that they had been in foster care system
- 34% identified as having indigenous ancestry
- 38% had lived in Vernon for less than 1 year
- 50% indicated that they had grown up in Vernon or had family connections

MAIN CAUSES OF HOMELESSNESS IN VERNON

- The main cause of homelessness in Vernon is low income, high rents and lack of available rentals
- When rental vacancy rates are low, people with barriers (such as mental health and substance use issues) are pushed out of the rental market. Although for many people with multiple barriers, supported housing is more appropriate than a private rental.
- There is not enough supported housing in Vernon to accommodate the number of people who are currently homeless or at risk of homelessness.

**
TURNING POINTS COLLABORATIVE
 102 3301 24 Ave
 Vernon, BC, V1T 9S8
 Phone: (250) 542-3555
SOCIAL PLANNING COUNCIL
 3105 33 Street
 Vernon BC, V1T 9P7
 Phone: (250) 540-8572

COOL Team

Vernon Homeless Outreach Team



it is in your hands to create a better world for all who live in it.

NELSON MANDELA

VERNON HOMELESS OUTREACH TEAM

Compassion without judgement



250-503-7680
homelessoutreachteamvernon@gmail.com



Find us on Facebook



We are a group of caring women who offer outreach to the homeless men and women of Vernon, BC.

We offer hygiene supplies, clothing, blankets, food and water to those living on the street.



We form relationships with the street population and offer emotional support as well as providing assistance with harm reduction (clean needles, antiseptic wipes and tinfoil) and Naloxone.

We are on the street at night, always at least 2 at a time for safety reasons.

We are always looking for new volunteers and provide training. Please give us a call if you are interested in joining our group.



*Together we CAN
make a difference*

OUTREACH SUPPLIES

**DONATIONS ARE GRATEFULLY
ACCEPTED**

- Hairbrushes**
- Makeup, nail polish**
- Tooth paste, tooth brushes**
- Dental floss**
- Shampoo and conditioner (hotel size)**
- Lotion (hotel size)**
- Shoes/sandals**
- Chapstick**
- Deodorant**
- Tampons/pads**
- Hand sanitizers (hotel size)**
- Wet wipes (individually wrapped)**
- Underwear**
- Bras**
- Purses**
- Clothes**
- Band aides**
- Chocolate**
- backpacks**
- pkg Kleenex (little ones)**
- bottled water**
- juice boxes**
- granola bars**
- disposable razors**
- Batteries (all sizes)**

- (For winter)**
- Blankets/sleeping bags**
- Hand/Foot warmers**
- Gloves**
- Scarves**
- toques**
- warm jackets**
- sweaters**
- boots**
- socks**



The Corporation of the City of Vernon COUNCIL DISCRETIONARY GRANT APPLICATION FORM



IMPORTANT: The deadline for Council Discretionary Grant Applications are semi-annual being April 30 and October 31 each calendar year.

Applications will only be accepted during the intake periods of April 1 - April 30 and October 1 to October 31. Applications must be submitted to the Director of Financial Services no later than 4:00pm on the application deadline (April 30th and October 31st), if City Hall is closed that day, on the next working day that City Hall is open.

Applicants may run the risk of grant funding being depleted if waiting to apply until the October intake deadline.

If grant applications are received after the cut off periods they will be returned to the applicant and must be submitted at the next intake period.

Please note: Incomplete applications will not be considered

ORGANIZATION INFORMATION

NAME OF ORGANIZATION APPLYING FOR COUNCIL DISCRETIONARY GRANT:	Vernon Paddling Centre Society
CONTACT PERSON:	Chris Hodgkinson
ORGANIZATION MAILING ADDRESS:	[REDACTED]
BUSINESS PHONE:	[REDACTED]
EMAIL ADDRESS:	[REDACTED]
REGISTERED NON PROFIT SOCIETY INCORPORATION NUMBER (required):	5-0030871

"Personal information contained on this form is collected under the *Freedom of Information and Protection of Privacy Act* and will be used only for the purposes of responding to your request".

City Hall Address: 3400 30th Street, Vernon BC, V1T 5E6
Inquiries: 250-545-1361
Web: www.vernon.ca



The Corporation of the City of Vernon COUNCIL DISCRETIONARY GRANT APPLICATION FORM

ORGANIZATION GOALS, OBJECTIVES AND ACTIVITIES:

The club is a not-for-profit organization devoted to the promotion of safe and skillful paddling. The Vernon Paddling Centre Society (VPCS) is a club of independent paddlers who enjoy outrigger canoeing and other paddling sports.

VPCS's mission is to promote a diverse paddling community, safety, and foster paddling to the community at large. We are always looking for new members.

SERVICE PROVIDED TO THE COMMUNITY:

We are trying to expand our equipment to provide inclusive outdoor recreational paddling for all abilities by providing adaptive equipment, opportunities, education and resources.

A PROFILE AND HISTORY OF THE ORGANIZATION AND ITS ACCOMPLISHMENTS:

For 2 years, VPCS has provided access to adaptive paddling. Adaptive paddling is empowering people within our community living with disabilities, the opportunity to access Okanagan Lake and enjoy water activities such as stand up paddle boarding, canoeing and kayaking. We are looking to continue expanding this program.

PLEASE IDENTIFY THE STEPS YOUR ORGANIZATION HAS TAKEN TO ACQUIRE GRANTS FROM OTHER SOURCES:

We have recently been provided a grant from BC Gaming for a new stand-up paddle board system, roll-out access mat and floatable wheelchair which is fantastic news.

The funds we would be requesting would go towards other required equipment for the program.

City Hall Address: 3400 30th Street, Vernon BC, V1T 5E6

Inquiries: 250-545-1361

Web: www.vernon.ca



The Corporation of the City of Vernon COUNCIL DISCRETIONARY GRANT APPLICATION FORM

GRANT REQUEST

(You may wish to provide attachments, please note below where these items can be found.)

AMOUNT OF REQUEST:

We have been quoted a total of \$1,405.60 for the required equipment.

IN-KIND SERVICES: (please describe and include cost)

At the moment, our services of the members are voluntary. We provide assistance to members who are disabled when they would like to paddle. It could be estimated that at \$20/hour x 3 hours x 6 members per session x 4 sessions per year, an in-kind services cost would be \$1,440 - This is on-water services and does not include voluntary hours spent developing the programs and administration services such as writing grant applications.

PURPOSE OF GRANT AND PROPOSED ALLOCATION OF FUNDS:

The Duo-Flo Stabilizers will allow us to modify 2 custom built wheelchair paddle boards and a kayak so that we can safely take our users out on the water. They are easy to assemble and add to our equipment and would greatly enhance our ability to expand our programs and opportunities.

BENEFITS TO COMMUNITY RESULTING FROM GRANT OR CITY GOALS AND OBJECTIVES THAT WILL BE MET, IF THE GRANT IS APPROVED:

Due to our limited adaptive paddling equipment at the moment, we only have a few craft available. By purchasing these stabilizers, we will now be able to offer a wider variety of paddling opportunities to our adaptive persons and allow groups to participate in this activity several at a time, instead of currently having to wait on-shore for their turn.

DEGREE OF COMMUNITY FINANCIAL SUPPORT OR SPONSORSHIP:

Our new program will be facilitated by a skilled Therapeutic Recreation Practitioner and paddling instructor. We have the support of a number of disability and seniors service organizations who are looking forward to accessing our adaptive opportunities when we officially launch, this coming spring 2020.

City Hall Address: 3400 30th Street, Vernon BC, V1T 5E6

Inquiries: 250-545-1361

Web: www.vernon.ca



The Corporation of the City of Vernon

COUNCIL DISCRETIONARY GRANT APPLICATION FORM

DEGREE OF DEMONSTRATED ECONOMIC DEVELOPMENT, ENVIRONMENTAL STEWARDSHIP OR SOCIAL BENEFIT THAT MAY BE GENERATED BY THE AWARD OF A COUNCIL DISCRETIONARY GRANT:

The social benefit provided to our adaptive paddlers is incredible. For them to be able to participate in an activity they thought they would never be able to due to them being wheelchair bound or living with another form of disability is such an uplifting experience. We want to be the leaders in this program in the Okanagan and be proud to support our adaptive paddling community by providing them with the opportunity to experience the abundant nature resources we have access to here in Vernon.

GRANT QUALIFICATION CHECKLIST (please check all that apply):

- Community Based
- Providing a service which is not provided by any other group or organization within the City or which is provided for in another municipality and used by residents
- Must only submit one application per calendar year
- Grant request is not to cover retroactive funding or to cover a deficit

Note: Organizations do not qualify for the discretionary grant program if they are in receipt of regional funding or are receiving grants or other assistance from the City of Vernon.

GRANT REQUIREMENTS (please attach to your grant application):

- Most Recent Set of Financial Statements
- Minutes of Most Recent Annual General Meeting
- List of Members of the Executive (including positions held, address and contact numbers)

In the case of newly formed groups, a budget and information regarding the organization purpose including list of Board of Directors will be sufficient.

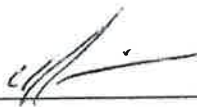
Oct 30, 2019

 Date Signature

City Hall Address: 3400 30th Street, Vernon BC, V1T 5E6
Inquiries: 250-545-1361
Web: www.vernon.ca

Vernon Paddling Centre Sociey
Balance Sheet As at 10/29/2019

ASSET**Current Assets**

Gaming Bank Account	13.78	
Chequing Bank Account	2,770.35	
Member Reward & Equity Shares	73.45	
Total Cash		2,857.58
Total Current Assets		2,857.58

Other Non-Current Assets

Boats	117,049.34	
Accum Deprec. Boats	-82,241.41	
Buildings	24,328.42	
Accum Deprec. - Buildings	-7,120.71	
Trailers	21,500.00	
Accum Deprec. - Trailers	-6,500.00	
Equipment	7,576.60	
Accum Deprec. - Equipment	-6,956.60	
Total Other Non-Current Assets		67,635.64

TOTAL ASSET 70,493.22

LIABILITY**Current Liabilities**

Trailer Loan	15,000.00	
Ultra light boat loan	10,000.00	
Total Current Liabilities		25,000.00

TOTAL LIABILITY 25,000.00

EQUITY**Owners Equity**

Retained Earnings - Previous Year	34,827.34	
Current Earnings	10,665.88	
Total Owners Equity		45,493.22

TOTAL EQUITY 45,493.22

LIABILITIES AND EQUITY 70,493.22

Vernon Paddling Centre Sociey
Income Statement 01/01/2019 to 10/29/2019

REVENUE

Sales Revenue		
Membership Dues	15,630.00	
Storage Rental Income	100.00	
Drop In Paddle Fee	80.00	
Interest Income	3.76	
Film Festival Income	3,239.00	
Film Festival Sponsorships	1,500.00	
Net Sales	<u>20,552.76</u>	
Other Revenue		
T-Shirt Sales	150.00	
Total Other Revenue	<u>150.00</u>	
TOTAL REVENUE		<u>20,702.76</u>

EXPENSE

Cost of Goods Sold		
Film Festival Expenses	1,937.25	
Net Purchases		1,937.25
Total Cost of Goods Sold		<u>1,937.25</u>
General & Administrative Expe...		
Business Fees & Licenses		40.00
CORA Club Fees		150.00
Coaching Programs		2,200.00
Insurance		3,071.00
Interest & Bank Charges		36.00
Zone 4 Processing Fees		588.90
Office Supplies		545.63
Repair & Maintenance		114.47
T Shirts		653.59
Supplies		210.00
Social Events & Entertainment		106.38
Website		383.66
Total General & Admin. Expen...		<u>8,099.63</u>
TOTAL EXPENSE		<u>10,036.88</u>
NET INCOME		<u>10,665.88</u>

Vernon Paddling Meeting AGM Oct. 15, 2019, 7:30- 8:30 pm

NEXT Meeting: Thursday Nov. 14 7:00pm at Marten's Brew Pub.

Meeting held at the Outboard Pub, Okanagan Landing Road, Vernon BC

VPC Board Attendees; Chris Hodgkinson, Bob Woodman, Anne-Marie Tosse, Patty Ellis, Lorelei Sullivan, David Chambers

VPC Member Attendees: 16 members attending

Meeting called to order by the Chair (Chris Hodgkinson)

Approval of Agenda: Motion to accept by Marcus Boyle , 2nd by Anne-Marie Tosse, all in favour no opposition, motion approved

Reflections of last year:

New Boat: Chris reported:

- Chris reported the new 6 man boat has gone to races, being used on regular bases, and is being paid off. Approx. \$10,000.00 left to be paid off.
- These new boats are light weight and easy to handle weight of boat is 160 lbs versus 400lbs that VPC has now.
- Cost of one boat is 30 thousand dollars

GRANTS: Chris reported:

- BC gaming grant is usually decided by this time, but the web site indicates that the decision is still in progress.
- A grant from Cora was awarded for \$1000.00.
- Vernon Council Grant is being applied for.

Film Festival: Chris reported

- Anne reported that the Film Festival in 2019 made 2,165.25, in 2018 income was \$ 3878.82.
- The organizing of the film festival takes time to knock on door and get door prizes and sponsorship as well as coordinating films, location etc. Bob has suggested not getting door prizes this year and increasing the ticket prices from the early bird \$12.00 and at door \$15.00 to \$17.00.
- Patty is unable to be the lead on this in 2020.
- The number of sponsors for the film festival in 2019 was 10 and a dedicated number of sponsors from year to year have made this possible.
- Deb Hunter has agreed to carry on this worthwhile fund raiser. Diana and Patty have templates etc. that can be passed onto this committee. Patty willing to help out but not as lead organizer.

SOCIAL EVENTS: Anne reported

- Laura Fowler had a summer party, and was well attended and wine won from the previous year was well appreciated.
- David Chambers had an end of season party at his mountain retreat was well attended in spite of the weather. Thank you to both members for hosting.
- Huli Party was well attended and organized by Marcus and then a great pizza feast afterwards.
- Thanks to all these wonderful members for taking on these fun filled events.

Website and on-line registration: Chris reported:

- The new website and online registration is fabulous. Big thank you to Glenn for taking the lead on this. Glenn can also have the new code for the locks on the website registration form for 2020. Once people register they will get the new code as well.
- CORA registration will need to be paid separately, if you are racing and cost is approximately \$25.00.
- Chris is available to any members who are having issues with online registration.

ACTION ITEM: New code on Locks to be changed prior to 2020 registration? WHO will do this? Discussion of Membership fees to be determined at November meeting

MEMBERSHIP: Lorelei reported:

- VPC has 76 members Versus 68 last year. Goal for 2019 year was better tracking of boats that are being stored. Lorelei reported there are 26 boats being stored in compound

Coaching: Glenn Reported:

- Key events that were attended by VPC members were Penticton Dual in the Desert Race. Kelowna Race father's day weekend (3 boats) Harrison Lake VPC had crew in each race that was participated in and medalled in two of the three races. One brave soul did an OC 1 race on the Sunday and another in an OC2. Congrats Karin and Randy.
Length of the Lake Sept. long weekend

Learn to Paddle: Glenn reported:

- Small participation approx. ½ a dozen people were met ½ hour before regular practise and were given an orientation and then brought out in the 6 man boats
- New Members also utilized the OC 1 and OC 2 and paddle boards.
- Recommendation is to have more recreation nights during the week and to recruit or train up a steersperson to assist with this. Marcus Boyle will assist with this along with Wendy and Patty.
- Marcus along with Patty to set up specific dates and times for recreation paddlers, Wendy suggested bringing together race and recreation paddlers together for fun paddles for cohesion.
- Marcus is willing to do a steering clinic to assist with getting members comfortable for taking new folks out in 6 man boats.

ACTION ITEM: Board to send out a survey asking recreation paddler what their needs are etc. to be discussed at November meeting.

COMPOUND MOVE/ New Storage: Bob reported:

- Nut hut has been moved (craned) so that Access Revolution can use that space.
- Racks have been built, and in the future could see about 60 boats being stored in the new storage area.
- Bob planning on Revamping storage and go back to cubbyhole type of system to slide boats in and out of
- There is a lot of interest from people re storing boats. Need to promote Boat Storage more.
- Bob will be working on getting siding for the new storage building to fit in with the rest of Paddlewheel Park.

TO DO in spring of 2020: carry on with this initiative.

- Put stickers on boats and numbers to keep track of boats and who they belong to. Bob said that Kelowna paddling Centre has a system that does this.

Access Revolution: Sonja reported:

- There were 4 1:1 adaptive paddling sessions over the summer at VPC. Three large adaptive paddling events at Fintry, Shuswap Lake, Lac Le Jeune. VPC also assisted with getting Sonja out in the OC6 on Thanksgiving weekend in a 6 man boat.

- Sonya and Jordan are asking for donations from Home Hardware but need assistance with making sure they get the proper material for Ramp and Racks on outside of Nut Hut.
- Marcus and Bob can assist with this
- **ACTION:** Sonja to give Marcus specific measurements for ramp etc. and let Marcus know so materials can be ordered.

FINANCIALS REPORT:

Anne and Chris signed off on the 2018 financials. Signed and approved 1st by Bob and 2nd by Deb, all in favour, motion approved

Correctness of accounts for 2019, Chris to certify, with Anne, Marcus motioned to pass Judy 2nd all in favour.

Directors Election:

Motion to accept directors at large, 1st by Wendy, 2nd by Kim, all in favor, motion approved:

- ***Patty Ellis***
- ***Bob Woodman***
- ***Lorelei Sullivan***
- ***Anne Tosse***
- ***Christopher Hodgkinson***
- ***Diana Wilson resigned from board***
- ***Sonja nominated 1st by Anne 2nd by Patty all in favour***
- ***Sonja Gaudet***

OPEN FORUM:

- Murray interested in getting SUP paddlers together to train for the race on Kalamalka Lake that takes place in August. Suggestion was 6 weeks out to have a training session on tactics and form etc.
- Nominated for 2021 for VPC to host Fresh Water Challenge Change Race on the August long weekend. (Approx. 43 km) will need all hands on deck to organize and volunteer for the day.
- Glenn asked re time line to pay off the new boat. Target for boat paid off 2020. Chris is working on grants etc. Time line is August- September 2020.

- Work Party Oct. 27th at 10am. Lorelei will send out to membership to assist.
- Other events that took place that VPC were involved with was the Yacht Club Boat show, not very well attended not sure how much interest there was for VPC, we do this for the neighbourly aspect
- VPC volunteered for the Kal triathlon where approx. 6 members assisted with watching the swimmers.

Meeting adjourned

Motioned by Anne 2nd by Wendy all in favor.

(http://www2.gov.bc.ca/) **Societies Online**

Patricia Ellis | Log Out (https://www.bcregistry.ca/societies/regi_logout)

LIST OF DIRECTORS



Loading...

VERNON PADDLING CENTRE SOCIETY

Incorporation Number	S0030871
Business Number	84717 6088 BC0001
Status	ACTIVE
Member Funded	No

Annual Report (https://www.bcregistry.ca/societies/S0030871/filing/annual_report?year=2019)	\$40.00
Change of Directors (https://www.bcregistry.ca/societies/S0030871/filing/changeOfDirectors)	\$15.00
Change of Address (https://www.bcregistry.ca/societies/filing/changeOfAddress?corpNum=S0030871)	\$15.00
Change to Bylaws (https://www.bcregistry.ca/societies/filing/bylawAlteration?corpNum=S0030871)	\$50.00
<input type="checkbox"/> More Options (https://www.bcregistry.ca/societies/S0030871/dashboard#sm)	

Society's Registered Office Address

(<https://www.bcregistry.ca/societies/filing/changeOfAddress?corpNum=S0030871>)

Address Requirements

Delivery Address

Mailing Address



Society's Email Address

Why is an Email Address requested?

Edit (<https://www.bcregistry.ca/societies/S0030871/dashboard#>)

Primary Email





The Corporation of the City of Vernon

COUNCIL DISCRETIONARY GRANT APPLICATION FORM

IMPORTANT: The deadline for Council Discretionary Grant Applications are semi-annual being April 30 and October 31 each calendar year.

Applications will only be accepted during the intake periods of April 1 - April 30 and October 1 to October 31. Applications must be submitted to the Director of Financial Services no later than 4:00pm on the application deadline (April 30th and October 31st), if City Hall is closed that day, on the next working day that City Hall is open.

Applicants may run the risk of grant funding being depleted if waiting to apply until the October intake deadline.

If grant applications are received after the cut off periods they will be returned to the applicant and must be submitted at the next intake period.

Please note: Incomplete applications will not be considered

ORGANIZATION INFORMATION

NAME OF ORGANIZATION APPLYING FOR COUNCIL DISCRETIONARY GRANT:	VERNON PICKLEBALL ASSOC
CONTACT PERSON:	MYRON HOCEVAR
ORGANIZATION MAILING ADDRESS:	P.O. BOX 844 VERNON BC V1T 6M8
BUSINESS PHONE:	—
EMAIL ADDRESS:	VERNONPICKLEBALL@GMAIL.COM
REGISTERED NON PROFIT SOCIETY INCORPORATION NUMBER (required):	S-006337

"Personal information contained on this form is collected under the *Freedom of Information and Protection of Privacy Act* and will be used only for the purposes of responding to your request".

City Hall Address: 3400 30th Street, Vernon BC, V1T 5E6
 Inquiries: 250-545-1361
 Web: www.vernon.ca



The Corporation of the City of Vernon
COUNCIL DISCRETIONARY GRANT APPLICATION FORM

ORGANIZATION GOALS, OBJECTIVES AND ACTIVITIES:

TO PROMOTE THE DEVELOPMENT AND GROWTH OF ALL ASPECTS OF THE GAME OF PICKLEBALL - SOCIAL, RECREATIONAL AND COMPETITIVE - TO INDIVIDUALS OF ALL AGES AND ABILITIES IN GREATER VERNON

SERVICE PROVIDED TO THE COMMUNITY:

PROVIDE A SAFE, WELL MAINTAINED AND OPERATED FACILITY TO PLAY OUTDOOR PICKLEBALL FOR BOTH THE CLUB AND PUBLIC ALIKE.

A PROFILE AND HISTORY OF THE ORGANIZATION AND ITS ACCOMPLISHMENTS:

THE ORGANIZATION WAS CREATED NOVEMBER 2015 BY MERGING TWO DIFFERENT PICKLEBALL CLUBS. IT HAS SPEARHEADED THE MARSHALL FIELDS DEDICATED PICKLEBALL COURTS FACILITY BEING BUILT AND TOGETHER WITH \$300K OF CITY/GVAC FUNDING, BUILT A \$1.4 MILLION FACILITY THAT WAS OPERATIONAL AUGUST 2018

PLEASE IDENTIFY THE STEPS YOUR ORGANIZATION HAS TAKEN TO ACQUIRE GRANTS FROM OTHER SOURCES:

SOLICITATION OF GRANTS HAS SO FAR ONLY HAD 2 SUCCESSES: 1) \$2500 GAMING GRANT & 2) \$5000 55+ GAME1 LEGACY GRANT. PART OF OUR CHALLENGE IS THE CITY OWNS THE LAND AND WILL TAKE BACK THE FACILITY WHEN OUR LEASE EXPIRES



The Corporation of the City of Vernon

COUNCIL DISCRETIONARY GRANT APPLICATION FORM

GRANT REQUEST

(You may wish to provide attachments, please note below where these items can be found.)

<u>AMOUNT OF REQUEST:</u> \$3000												
<u>IN-KIND SERVICES: (please describe and include cost)</u> VOLUNTEERS WILL BE USED TO TRENCH THE DITCH WHERE THE WIRING FOR THE NIGHT LIGHTING POLES AND CAMERAS WILL BE INSTALLED, SAVINGS TO COST OF SECURITY SYSTEM ESTIMATED TO BE \$8000												
<u>PURPOSE OF GRANT AND PROPOSED ALLOCATION OF FUNDS:</u> TO ACQUIRE AND INSTALL SECURITY CAMERAS AT THE MARSHALL FIELDS PICKLEBALL FACILITY, COST OF CAMERAS, MONITOR, DVR + SET-UP ESTIMATED TO BE \$4000												
<u>BENEFITS TO COMMUNITY RESULTING FROM GRANT OR CITY GOALS AND OBJECTIVES THAT WILL BE MET, IF THE GRANT IS APPROVED:</u> THE MARSHALL FIELDS PICKLEBALL FACILITY WILL BE MUCH LESS PRONE TO VANDALISM AND ENHANCE ITS ABILITY TO KEEP PUBLIC AND CLUB USERS SAFE												
<u>DEGREE OF COMMUNITY FINANCIAL SUPPORT OR SPONSORSHIP:</u> <table style="margin-left: auto; margin-right: auto; border-collapse: collapse;"> <tr> <td style="padding: 5px; text-align: right;">25 %</td> <td style="padding: 5px; text-align: right;">3000</td> <td style="padding: 5px;">GRANT</td> </tr> <tr> <td></td> <td style="padding: 5px; text-align: right;">1000</td> <td style="padding: 5px;">VPA CASH</td> </tr> <tr> <td></td> <td style="padding: 5px; text-align: right;">8000</td> <td style="padding: 5px;">IN-KIND VOLUNTEER LABOR</td> </tr> <tr> <td></td> <td style="padding: 5px; text-align: right; border-top: 1px solid black;">12,000</td> <td></td> </tr> </table>	25 %	3000	GRANT		1000	VPA CASH		8000	IN-KIND VOLUNTEER LABOR		12,000	
25 %	3000	GRANT										
	1000	VPA CASH										
	8000	IN-KIND VOLUNTEER LABOR										
	12,000											



The Corporation of the City of Vernon

COUNCIL DISCRETIONARY GRANT APPLICATION FORM

DEGREE OF DEMONSTRATED ECONOMIC DEVELOPMENT, ENVIRONMENTAL STEWARDSHIP OR SOCIAL BENEFIT THAT MAY BE GENERATED BY THE AWARD OF A COUNCIL DISCRETIONARY GRANT:

VPA CLUB MEMBERSHIP CONTINUES TO GROW (430 AS OF AUGUST 2019) YOUTH GROUPS ARE BEING INTRODUCED TO THE GAME BY VPA MEMBERS. GROWING PUBLIC USE - ACTIVATE THEIR

LIFESTYLE

GRANT QUALIFICATION CHECKLIST (please check all that apply):

- Community Based
- Providing a service which is not provided by any other group or organization within the City or which is provided for in another municipality and used by residents
- Must only submit one application per calendar year
- Grant request is not to cover retroactive funding or to cover a deficit

Note: Organizations do not qualify for the discretionary grant program if they are in receipt of regional funding or are receiving grants or other assistance from the City of Vernon.

GRANT REQUIREMENTS (please attach to your grant application):

- Most Recent Set of Financial Statements
- Minutes of Most Recent Annual General Meeting
- List of Members of the Executive (including positions held, address and contact numbers)

In the case of newly formed groups, a budget and information regarding the organization purpose including list of Board of Directors will be sufficient.

OCT 4, 2019

Date

Myron Hocovar

Signature

MYRON HOCEVAR

VERNON PICKLEBALL ASSOCIATION

Financial Statements

Year Ended August 31, 2019

(Unaudited - See Notice To Reader)

VERNON PICKLEBALL ASSOCIATION
Index to Financial Statements
Year Ended August 31, 2019
(Unaudited - See Notice To Reader)

	Page
NOTICE TO READER	1
FINANCIAL STATEMENTS	
Statement of Financial Position	2
Statement of Changes in Net Assets	3
Statement of Revenues and Expenditures	4
Notes to Financial Statements	5

NOTICE TO READER

On the basis of information provided by management, I have compiled the statement of financial position of Vernon Pickleball Association as at August 31, 2019 and the statements of changes in net assets and revenues and expenditures for the year then ended.

I have not performed an audit or a review engagement in respect of these financial statements and, accordingly, I express no assurance thereon.

Readers are cautioned that these statements may not be appropriate for their purposes.

Robin D. Bristow Ltd.

Vernon, BC
September 11, 2019

CHARTERED PROFESSIONAL ACCOUNTANT

VERNON PICKLEBALL ASSOCIATION
Statement of Financial Position
August 31, 2019
(Unaudited - See Notice To Reader)

	2019	2018
ASSETS		
CURRENT		
Cash	\$ 25,652	\$ 22,118
Restricted cash - new courts	36,425	31,207
Restricted cash - gaming	-	2,500
Goods and services tax recoverable	1,393	26,256
	63,470	82,081
PROPERTY AND EQUIPMENT (Note 2)	635,179	583,853
	\$ 698,649	\$ 665,934
LIABILITIES AND NET ASSETS		
CURRENT		
Accounts payable	\$ 1,500	\$ 1,500
Current portion of long term debt (Note 3)	14,500	-
	16,000	1,500
LONG TERM DEBT (Note 3)	130,500	145,000
DEFERRED INCOME	413,612	447,659
	560,112	594,159
NET ASSETS		
Unrestricted net assets	75,988	53,177
Equity in property and equipment	62,549	18,598
	138,537	71,775
	\$ 698,649	\$ 665,934

VERNON PICKLEBALL ASSOCIATION
Statement of Changes in Net Assets
Year Ended August 31, 2019
(Unaudited - See Notice To Reader)

	Unrestricted Net Assets	Equity in Property and Equipment	2019	2018
NET ASSETS - BEGINNING OF YEAR	\$ 53,177	\$ 18,598	\$ 71,775	\$ 52,447
EXCESS OF REVENUES OVER EXPENSES	66,762	-	66,762	19,328
AMORTIZATION	44,214	(44,214)	-	-
TRANSFERS	(88,165)	88,165	-	-
NET ASSETS - END OF YEAR	\$ 75,988	\$ 62,549	\$ 138,537	\$ 71,775

VERNON PICKLEBALL ASSOCIATION
Statement of Revenues and Expenditures
Year Ended August 31, 2019
(Unaudited - See Notice To Reader)

	2019	2018
REVENUES		
Session passes	\$ 53,625	\$ 54,354
Deferred capital contributions	34,047	-
Membership dues	33,846	11,100
Fundraising	13,354	-
Tournament fees	13,072	7,287
Sponsorship - Hollis Wealth	12,000	12,000
Donations	8,325	-
Sponsorships - others	5,762	-
Lessons and clinics	2,294	3,766
Apparel (net)	21	30
Gaming income	-	2,500
	176,346	91,037
EXPENSES		
Amortization	44,214	-
Fundraising expenses	3,715	-
Insurance	2,817	3,245
Lessons and clinic	-	1,253
Office	4,091	2,904
Pickleball Canada	2,080	1,925
Professional fees	1,737	12,193
Rental	36,709	42,881
Repairs and maintenance	4,199	-
Small equipment	2,717	2,168
Tournament costs	6,223	4,055
Website	1,082	1,085
	109,584	71,709
EXCESS OF REVENUES OVER EXPENSES	\$ 66,762	\$ 19,328

See notes to financial statements

VERNON PICKLEBALL ASSOCIATION

Notes to Financial Statements

Year Ended August 31, 2019

(Unaudited - See Notice To Reader)

1. PURPOSE OF THE ORGANIZATION

Vernon Pickleball Association (the "Association") is a not-for-profit organization incorporated provincially under the Societies Act of British Columbia on November 27, 2014. The purpose of the Association is to promote and manage the sport of pickleball in the greater Vernon area.

2. PROPERTY AND EQUIPMENT

	Cost	Accumulated amortization	2019 Net book value	2018 Net book value
Marshall Fields Pickleball Courts	\$ 679,393	\$ 44,214	\$ 635,179	\$ 583,853

The Marshall Fields pickleball courts are on land leased from the City of Vernon for \$1 per year. The original lease has a 5 year term, with two 5-year renewal options. Amortization of the courts began in fiscal 2019 over 14 years using the declining balance method.

3. LONG TERM DEBT

	2019	2018
City of Vernon, non-interest bearing, repayable at \$14,500 per year starting in December 2019	\$ 145,000	\$ 145,000
Amounts payable within one year	(14,500)	-
	\$ 130,500	\$ 145,000

4. REMUNERATION OF OFFICERS, DIRECTORS, EMPLOYEES AND SUPPLIERS

The Societies Act of British Columbia requires that all not-for-profit organizations incorporated under its statutes report the following:

Remuneration to Officers and Directors during the year: \$nil

Remuneration to employees greater than \$75,000 during the year: \$nil

Payments to suppliers greater than \$75,000 for the year: \$nil



2019 BC SOCIETY ANNUAL REPORT

BC Society • Societies Act

NAME OF SOCIETY: **VERNON PICKLEBALL ASSOCIATION**

Incorporation Number:

S0063337

Business Number:

82274 3589 BC0001

Filed Date and Time:

September 20, 2019 06:24 PM Pacific Time

Annual General Meeting (AGM) Date:

September 19, 2019

REGISTERED OFFICE ADDRESS INFORMATION

Delivery Address:

DELIVER TO POST OFFICE MAIL BOX
PO BOX 844 PO VERNON
VERNON BC V1T 6M8

Mailing Address:

DELIVER TO POST OFFICE MAIL BOX
PO BOX 844 PO VERNON
VERNON BC V1T 6M8

DIRECTOR INFORMATION AS OF September 19, 2019

Last Name, First Name Middle Name:

ELLINGSEN, CARRIE

Delivery Address:

[REDACTED]

Last Name, First Name Middle Name:

HOCEVAR, MYRON

Delivery Address:

[REDACTED]

Last Name, First Name Middle Name:

IRVING, ROB

Delivery Address:

[REDACTED]

Last Name, First Name Middle Name:

MARX, RYNETTE

Delivery Address:

[REDACTED]

Last Name, First Name Middle Name:

PADULA, DARELL

Delivery Address:



Last Name, First Name Middle Name:

PIPER, SCOTT

Delivery Address:



Last Name, First Name Middle Name:

STAUB, RICK

Delivery Address:



CERTIFICATION

I, Myron Hocevar, certify that I have relevant knowledge of the society, and that I am authorized to make this filing.



**Vernon Pickleball Annual General Meeting 2019
MINUTES**

Date: Thursday September 19, 2019

Location: Marshall Fields Soccer Center 6601 25 Ave

Presiding chairman Rob Irving called the AGM to order at 7:30 pm

Rob reported that 64 verified members were present of the official membership of 430 and that the quorum of 43 members had been met.

It is noted that 2018/2019 Board Members were all present: Rick Sluggett, Rob Irving, Shannon McClean, Rick Wadsworth, Myron Hocevar, Ian Phillips, Rick Staub

Motion:

To approve the agenda as circulated by email notice to all members.

Moved: Abe Pettyjohn Seconded: Peter McClean Motion: Carried

Motion:

To receive the officer's reports as circulated by email notice to all members.

- President – Rob Irving
- Treasurer – Rick Sluggett
- Vice President – Ian Phillips
- Secretary – Myron Hocevar
- Director at Large – Shannon McClean
- Director at large – Rick Wadsworth
- Director at Large – Rick Staub

Moved: Abe Pettyjohn Seconded: Rynette Marx

Motion: Carried

Motion:

To approve the September 20, 2018 AGM Minutes

Moved: Gerry Forcier Seconded: Rod Townsley Motion: Carried

The chairman introduced Robin Bristow CPA, CA CFE, the Financial Accountant who was engaged by the Board of Directors to complete a financial compilation of the fiscal year Sept 1, 2018 to August 31, 2019

The completed official financial statements, approved as indicated by the Board of Directors September 18, 2019 meeting minutes, were presented by Robin Bristow on a screen for the members to review. The chairman opened the floor for discussion. No questions were asked by the membership regarding the financial statements.

Motion:

To waive the audit requirement as per our bylaws and accept instead the 2018- 2019 financial compilation report as presented by Robin Bristow

Moved: Abe Pettyjohn Seconded: Nancy Aggasiz Motion: Carried

The chairman introduced Rick Sluggett who presented the Board approved 2019/20 Budget on a screen for the members to review.

Motion:

To approve the 2019/20 Budget

Moved: Gerry Forcier Seconded: Marv Friesen Motion: Carried

The chairman indicated that there were five accepted nominations for Board of Director positions that had summaries of their experience and anticipated contribution emailed to members

- Rob Irving
- Rick Staub
- Carrie Ellingsen
- Myron Hocevar
- Darell Padula

The chairman then opened the floor for additional nominations. Ian Phillips nominated Scott Piper who accepted the nomination and Abe Pettyjohn nominated Rynette Marx who accepted the nomination. The chairman then asked three times for any further nominations. There being none, the new Board was accepted by acclamation as there were only seven nominees for the seven available positions.

Motion:

To adjourn the AGM Meeting

Moved: Eva Hambley Seconded: Pat Andrews

Motion: Carried

The chairman adjourned the meeting at 8:32 pm.



The Corporation of the City of Vernon

COUNCIL DISCRETIONARY GRANT APPLICATION FORM

IMPORTANT: The deadline for Council Discretionary Grant Applications are semi-annual being April 30 and October 31 each calendar year.

Applications will only be accepted during the intake periods of April 1 - April 30 and October 1 to October 31. Applications must be submitted to the Director of Financial Services no later than 4:00pm on the application deadline (April 30th and October 31st), if City Hall is closed that day, on the next working day that City Hall is open.

Applicants may run the risk of grant funding being depleted if waiting to apply until the October intake deadline.

If grant applications are received after the cut off periods they will be returned to the applicant and must be submitted at the next intake period.

Please note: Incomplete applications will not be considered

ORGANIZATION INFORMATION

NAME OF ORGANIZATION APPLYING FOR COUNCIL DISCRETIONARY GRANT:	VERNON SKI CLUB
CONTACT PERSON:	Bridget Grant
ORGANIZATION MAILING ADDRESS:	PO Box 135, Vernon, BC V1T 6M1
BUSINESS PHONE:	[REDACTED]
EMAIL ADDRESS:	[REDACTED]
REGISTERED NON PROFIT SOCIETY INCORPORATION NUMBER (required):	50040792

"Personal information contained on this form is collected under the *Freedom of Information and Protection of Privacy Act* and will be used only for the purposes of responding to your request".

City Hall Address: 3400 30th Street, Vernon BC, V1T 5E6
Inquiries: 250-545-1361
Web: www.vernon.ca



The Corporation of the City of Vernon

COUNCIL DISCRETIONARY GRANT APPLICATION FORM

ORGANIZATION GOALS, OBJECTIVES AND ACTIVITIES:

Our programs prepare athletes for competition in Slalom, Giant Slalom, Super G & Downhill alpine disciplines. We are members and affiliates of BC Alpine and Alpine Canada. Vernon Ski Club (VSC) is lead by 100% volunteer parents and only coaches are compensated. Alpine skiing is a technical sport with strict rules & regulations requiring higher qualified coaching and officials than typical youth sports. Our head coach is a professional Level 4 Ski Instructor (highest certification possible) & Canadian Ski Coaches Federation 'Development Level Coach' certified and our youngest athlete coaching requires a minimum 'Entry level trained'. Each race requires an impartial (ie. out of town) Technical Director to supervise and control the event ensuring national and provincial rules & regulations are followed. *MISSION STATEMENT attached

SERVICE PROVIDED TO THE COMMUNITY:

SKI SWAP

- annual Ski Swap is planned, setup, executed and dismantled by Vernon Ski Club (VSC)
- over 1200 volunteer hrs documented (this year alone) for this event not including considerable planning hours
- promote a better quality of life by encouraging beginner, unsure or financially restricted skiers, snowboarders & cross-country skiers to start a healthy, outdoor sport by providing discounted new and used ski equipment
- approx. 4500 pieces were exchanged on consignment in 2019

SHARING IS CARING

- VSC shares race timing equipment and volunteers with non-member organizations/races typically open to the public such as: National Longboard Championships (on Middleton Mtn), Canada Cup and BC Cup Downhill Mountain Bike races, BC High School Alpine Ski Races, Over-the-Hill Downhill, Carter Classic (fundraiser for Silverstar Adaptive Snowsports School), National Telemark Championships, Silverstar Snowsports School races, BC Cup Frost-bike (mtn bike race on snow), Silver Star Mountain Resort's Seismic Festival, BC Special Olympics Provincials 2019, Hill Climb Snowmobile event, BC Winter Games 2022, U14 Provincials 2021

A PROFILE AND HISTORY OF THE ORGANIZATION AND ITS ACCOMPLISHMENTS:

- Built great skiers since 1935
- parents and coaches raised funds and built a club cabin in early 1990s
- VSC has always aimed to provide high level, quality coaching at an affordable cost to families (2018/19 COST PER DAY in VSC's U8-U12 Program = \$31-\$51/day, Silver Star Ski School = \$89/day)
- having a rich history in the ski industry has developed generations of ski families who graciously return to become the volunteers of our club and continue on the legacy
- skills like commitment, focus, discipline and composure developed with VSC are appreciated throughout our athletes entire lives on snow and at work with many athletes achieving the ranks of the BC Provincial Alpine Ski Team and Canadian National Alpine Ski Team as well as achieving excellence in their professional careers
- 231 members in 2019 (includes parents)
- VSC collaborates with Silver Star Adaptive Snowsports and BC Adaptive to integrate competitive para-skiers into their regular programs. Benefits include age specific programming and the added benefits of social/emotional growth and para-athlete retention skiing alongside non-para-athlete peers of the same age. Our visually impaired skier won several GOLD medals at Canadian Nationals in 2018/2019. More visually impaired and para skiers are expected this season.

PLEASE IDENTIFY THE STEPS YOUR ORGANIZATION HAS TAKEN TO ACQUIRE GRANTS FROM OTHER SOURCES:

BC Gaming Grant = \$5,000

Our board of directors recently formed a Grant Committee to apply for grants and funding to help offset the cost of timing equipment and upcoming capital expenditures. Future grants will be solicited from local and provincial not-for-profits like BC Capital Project Grant, Funtastic Community Grant, Kal Rotary Club, Kal Tire, ViaSport, Foord Family Foundation, etc.

City Hall Address: 3400 30th Street, Vernon BC, V1T 5E6

Inquiries: 250-545-1361

Web: www.vernon.ca



The Corporation of the City of Vernon

COUNCIL DISCRETIONARY GRANT APPLICATION FORM

GRANT REQUEST

(You may wish to provide attachments, please note below where these items can be found.)

<p><u>AMOUNT OF REQUEST:</u> \$5,000 * Official quote and equipment details attached</p>
<p><u>IN-KIND SERVICES: (please describe and include cost)</u> N/A</p>
<p><u>PURPOSE OF GRANT AND PROPOSED ALLOCATION OF FUNDS:</u> New Race Timing Equipment - wireless, modern timing technology designed to accurately measure the time from when wand is activated in start gate to breach of laser at finish</p> <ul style="list-style-type: none"> -100% of funds will be allocated to the purchase of new race timing equipment - \$5,000 grant would bring us to complete our fundraising goal
<p><u>BENEFITS TO COMMUNITY RESULTING FROM GRANT OR CITY GOALS AND OBJECTIVES THAT WILL BE MET, IF THE GRANT IS APPROVED:</u></p> <ul style="list-style-type: none"> - keep all athletes engaged in the sport by eliminating the frequent malfunctions associated with outdated equipment thereby maximizing ski time and limiting negative experiences from waiting, boredom, getting cold during races - ability to host dual slalom (2 skiers race on parallel and equal courses and are timed independently requiring a 2nd timing device) races increases the fun for kids and spectators as seen in World Cup racing events - share race timing gear with other not-for-profit groups within our community and reduce their expense related to renting race timing equipment and thereby reinvesting these savings into our community - purchasing expensive race timing equipment becomes cost prohibitive if there is only one race yearly partly due to capital cost and partly due to training long-term volunteers to use the equipment - demonstrated community need for race timing equipment and skilled timing operators by the extensive list of supported events as noted under 'SERVICE PROVIDED TO THE COMMUNITY'
<p><u>DEGREE OF COMMUNITY FINANCIAL SUPPORT OR SPONSORSHIP:</u> BC Gaming Grant = 50% Vernon Discretionary Fund = 50%</p>



The Corporation of the City of Vernon

COUNCIL DISCRETIONARY GRANT APPLICATION FORM

DEGREE OF DEMONSTRATED ECONOMIC DEVELOPMENT, ENVIRONMENTAL STEWARDSHIP OR SOCIAL BENEFIT THAT MAY BE GENERATED BY THE AWARD OF A COUNCIL DISCRETIONARY GRANT:

- upgrading to a wireless timing system keeps volunteer race crews from running wire through the forest and disrupting BC Parks vegetation thereby reducing our environmental footprint
 - wireless offers VSC mobility and flexibility when race venue is very long (ie. downhill) or changed by host mountain last minute
 - offering a smooth, accurate & efficient race experience keeps participants engaged, leaving with positive memories and encouraging future participation translating to favorable outcomes for Vernon tourism
 - faster setup/take down gives volunteers more energy to focus on the race and helps with volunteer burnout
 - data transfer is faster & easier leading to less stress on volunteers in timing booth & race office, fast results for athletes & coaches
 - fewer timing delays mean shorter wait times, more accurate results, shorter race days (positive for athletes & volunteers), and more time skiing/biking/snowmobiling to keep the passion alive
 - more reliable timing system provides opportunity to offer higher level races like PROVINCIALS and NATIONALS
- *see Estimate of Economic Impact for 2019 attached

GRANT QUALIFICATION CHECKLIST (please check all that apply):

- Community Based
- Providing a service which is not provided by any other group or organization within the City or which is provided for in another municipality and used by residents
- Must only submit one application per calendar year
- Grant request is not to cover retroactive funding or to cover a deficit

Note: Organizations do not qualify for the discretionary grant program if they are in receipt of regional funding or are receiving grants or other assistance from the City of Vernon.

GRANT REQUIREMENTS (please attach to your grant application):

- Most Recent Set of Financial Statements
- Minutes of Most Recent Annual General Meeting
- List of Members of the Executive (including positions held, address and contact numbers)

In the case of newly formed groups, a budget and information regarding the organization purpose including list of Board of Directors will be sufficient.

October 28, 2019

Date

Bridget Hunt

Signature

Vernon Ski Club

MISSION STATEMENT:

"Excellence in Skiing and in Life"

Our commitment to achieving this mission:

- build the best downhill technical skiers by offering fun, safe skill progression in an appropriate group with maximum time skiing
- learn how to ski the whole mountain: powder, bumps, ice, groomer, and gates - family orientated fun with parents strongly engaged in the organization
- keep group sizes small and coaches consistent each week - building respectful and gracious athletes who focus on individualized progression
- encourage friendships, positive social connections and leadership within the teams
- athlete retention through the critical development phase especially for females



SPORTS TIMING INTERNATIONAL
 7946 Hamilton Blvd., POB 774
 Trexlertown PA 18087
 Tel: 610/398-3977 Fax: 610/398-8406
 Email: info@phoenix-sports.com

Official Quote

NUMBER: 9779 REV A
 DATE : 7/10/19
 CLIENT NO. :
 REFERENCE : fkp

Customer:

Ship to:

Name: VERNON SKI CLUB
 Address: SILVER STAR RESORT
 Address: 1008 32ND AVE, UNIT 5
 City: VERNON
 PROV: BC
 PC: V1T 7X5
 Tel:
 Email:

Rod Williams, P.Gec

*includes the start gates,
 finish eyes, transmitters.

ORDER NO	ORDERED BY	TERMS	
EMAIL	Rod Williams	NET usd CHEQUE	
DATE ORDERED	SHIP VIA	SPECIAL CONDITIONS	
october 7 2019	UPS standard	N/A	
QTY	DESCRIPTION	UNIT PRICE	AMOUNT
			USD
2	AUTO CLOSE START GATES WITH JUMPER CABLES TO TRANSMITTERS		\$ 1,350.00
1	500MW ENC RADIO SF1 AND SF2 TRANSMITTERS WITH CLEAR HOLDERS FOR INDEPENDENT ATHLETE / STARTER INPUT		\$ 2,000.00
1	REI PRO DUAL TIMER WITH BATTERY CHARGER, 5 ROLLS THERMAL PAPER PC DATA CABLE, JUMPER CABLES, CASE		\$ 3,500.00
2	POLIFEMO RADIO PHOTOCELLS SF1 AND SF2 WITH WOODEN POSTS		\$ 1,950.00
1	DEC RADIO SF 1 AND SF2 RECIEVERS		\$ 940.00
1	CARRY BAG FOR ALL FINISH EQUIPMENT		\$ 350.00
2 YEAR WARRANTY			
PAYMENT & BILLING ADDRESS			
Phoenix Sports Technology, LLC			
POB 774 Trexlertown PA 18087-0774			
			USD
15% RESTOCKING FEE 18% INTEREST ON OUTSTANDING BALANCES 3% SURCHARGE FOR CREDIT CARD PURCHASES		Subtotal:	\$ 10,090.00
		Sales tax:	
		Shipping:	\$ 145.00
		CC fee 3%:	
		Total:	\$ 10,235.00

www.vernonskiclub.com

SALES TAX RATE	0.06
CC SURCHARGE 2.5%	
SHIPPING CHARGE	0.00

**if applicable, copy to invoice field
 surcharge includes sales tax & shipping**

America's most innovative timing & technical services provider

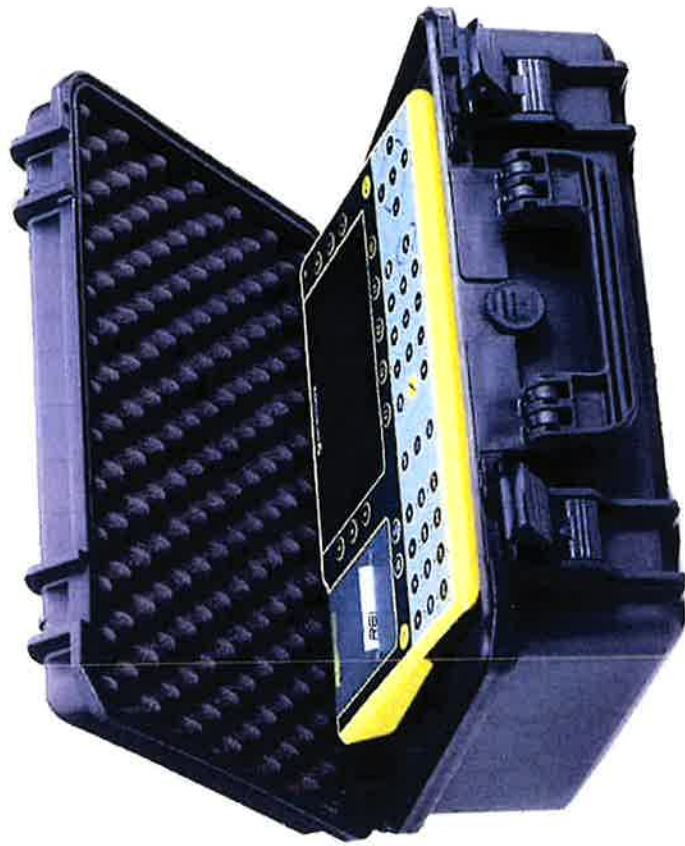

Estimate of Economic Impact for 2019

Data from Races Hosted by Vernon Ski Club in 2019

	Speed Camp	Zone Finals	Speed Camp Spending				Zone Final Spending			
	Jan	April	Pass	Accom	Meals	Total	Pass	Accom	Meals	Total
Apex	19	23	\$ 7,980	\$ 8,550	\$ 5,700	\$ 22,230	\$ 6,440	\$ 6,900	\$ 5,175	\$ 18,515
Big White	30	38	\$ 12,600	\$ 13,500	\$ 9,000	\$ 35,100	\$ 10,640	\$ 11,400	\$ 8,550	\$ 30,590
Revelstoke	5	13	\$ 2,100	\$ 2,250	\$ 1,500	\$ 5,850	\$ 3,640	\$ 3,900	\$ 2,925	\$ 10,465
Sun Peaks		30					\$ 8,400	\$ 9,000	\$ 6,750	\$ 24,150
Whistler		1					\$ 280	\$ 300	\$ 225	\$ 805
Yukon	8		\$ 3,360	\$ 3,600	\$ 2,400	\$ 9,360	\$ 0	\$ 0	\$ 0	\$ 0
Vernon	38	59								
	100	164	\$ 26,040	\$ 27,900	\$ 18,600	\$ 72,540	\$ 29,400	\$ 31,500	\$ 23,625	\$ 84,525
Event Days	3	2								
Meals/Day	\$75	\$75								
Athlete Pass/Day	\$50	\$50								
Adult Pass/Day	\$90	\$90								
Accommodation/Night	\$150	\$150								
Adult Passes/Athlete	1	1								
Nights Accom/Athlete	1	1								

Not included in estimate:

- economic impact related to non-VSC events from lending out timing equipment

Vernon Ski Club
Comparative Income Statement for the years ended May 31

	2019	2018
Revenue		
Program fees and memberships	\$144,785	\$112,381
Gaming funds	30,000	30,000
Fundraising	59,050	45,187
Ski swap	33,619	34,472
Race events	13,734	8,042
Total revenue	\$281,188	\$230,082
Expenses		
Association fees and dues	\$11,024	\$13,980
Building repairs and maintenance	3,695	12,866
Coaching	174,896	168,380
Equipment	2,417	15,272
Insurance	2,939	2,996
Uniforms - coaches and other	2,226	-
Office and general	4,834	3,862
Okanagan zone FIS team	5,000	5,000
Promotion and sponsor recognition	1,835	2,000
Radios and timing supplies	369	369
Utilities	4,265	6,601
Van operating costs	16,952	15,538
Total expenses	\$230,452	\$246,864
Excess (deficiency) of revenues over expenses	\$50,736	(\$16,782)
Net assets (deficiency), opening	(\$17,528)	(\$746)
Net assets (deficiency), closing	\$33,208	(\$17,528)

**Vernon Ski Club
Comparative Balance Sheet As At May 31**

	2019	2018
Assets		
Cash	\$38,487	\$18,259
Accounts Receivable	7,652	1,967
Supplies	-	2,744
Total assets	\$46,139	\$22,970
Liabilities		
Accounts Payable and Accrued Liabilities	\$12,931	\$40,498
Total liabilities	\$12,931	\$40,498
Net assets (deficiency)		
Unrestricted surplus (deficiency)	33,208	(17,528)
Total liabilities and net assets (deficiency)	\$46,139	\$22,970

On behalf of the Board:

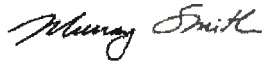

Director



Director

Minutes

Vernon Ski Club Annual General Meeting

Monday June 24, 2019, 7:00 PM

Marten's Brew Pub

7:05pm -call AGM to Order

For the purpose of this Annual General Meeting:

Aaron Robinson, Chairperson and President

Kurt Lahey, Treasurer and Director

Jeremy Guild, Secretary and Director

Present: Michael Milne; Kim Nasipayko; Lauren Carr; Marty Steele; James Phair; Steve Russell; Eiko Wada; Karen Ree; Franz Fux; Carrie Greene; Tyler Ferguson; Shawna Green; Roger Green; Ross Blankley; Adam White; Kurt Lahey; Murray Smith; Aaron Robinson; Jeremy Guild; Rodger Poole[Program Director].

1. Chairperson calls meeting to order
 2. Treasurer presents the financial statements for consideration as at and for the year ended May 31, 2019
 - See Financial statements, attached
 - Accounts receivables are up mostly for 2 sponsors; supplies down; accounts payable down due to repay loans from members;
 - Profit loss: more athletes in higher cost programs and increase costs for U12 and older; fundraising up approximately \$14,000 due to raffle proceeds and alumni donation ; ski swap is most significant fundraiser; speed camp = \$6,200; 43% of VSC funds come from fundraising: Q: does \$15,000 impact gaming grant? Murray – no; Kurt - we will likely have enough money to last through the summer when no funds come in. Expect approximately \$2,000 in cash by the end of September. Mike: grant from alumni was private.
 - FIS team donation (\$5,000) matches what all clubs contribute so they don't have to fund their own teams
 - \$40,000 cash balance is in effect keeping us neutral.
- No Questions
Murray points out that fundraising and sponsorships are fundamental to keeping the club fees affordable.
Thanks to Kurt and Murray

Resolution to accept the financial statements as presented

- Move: Carrie

- Second: Michael
- Vote: carried, 0 Nays

3. Report of Directors presented by the Chairperson
 - see report by Aaron, attached. Thanks to Aaron Marty – how many open spots for directors? Maximum 12, prefer 10, 9 former directors are willing to continue so would like 1 more
4. Report by Program Director, Rodger Poole
 - Thanks to Kim for sponsorship and promotion ideas and Aaron for leadership. For next year he would like to have more on snow options; improve coach to athlete ratios; perhaps expand a pilot project to manage splits more effectively, i.e. working with athletes of different ability who are the same age; mentorship of staff- want more formal coaches meetings on weekends, opportunities to set courses together and otherwise share and improve; dryland will continue with Fast and Fit into November; Trampoline is lined up with freestyle; academy will go to 11 athletes this year, 3 international: Italian, Spanish and German. One is 18 and two are 16; could have 2 more but van limitations mean at this point we can't meet the demand. Academy will continue to work with cross-fit. Volunteer parents help keep costs down. Cost for international athletes is \$7,000, which includes Snowsports Academy dryland and on snow training. That is approximately double the cost for non-international athletes to account for the considerable volunteer hours put in by parents in those programs.
 - Club is considering club wide fitness testing. Alpine Canada has guidelines and expectation of where athletes should be if they want to be on track for the National Team. Rodger thinks it is a good idea to give athletes a sense of fitness. It is not intended to be decisive, but a guideline, starting at U14. Aerobic fitness is not as good as Rodger would like to see. Next year he will try to go to May snow camps because weather issues lately (past two years) have resulted in cancellations so on-snow training is becoming a challenge. Also looking at diversifying to other camps for summer.
 - Other athlete numbers for next year are not clear. Overall numbers are stable, but there has been a drop in girls staying in club. Most coaches are returning.
 - Some discussion about MOU history and current process and goal of creating more certainty and rebuilding good will.
 - Key points are U7 numbers, grooming and reciprocal respect to not encroach on our respective programs. Jeremy: another factor is the SSSR promoting racing and VSC; and also wanting quality not quantity. Kim raises concerns about whether there are enough younger people. Other clubs have different models. There are other trade offs as well – cost of grooming and support of other parts of program. There is also other work like Lauren and communication committee to get out the message about our club being different from a common public perception of a ski club that exclusively trains gates/races.
 - A suggestion made by Eiko was to try to get feedback on why ski racing wasn't as much of an interest for those who are not continuing in the club.
 - In answer to a question regarding what programs will look like this year, Rodger said that most programs are going to be similar to last year, although he will try to get more skier days in with an earlier start to the season for younger athletes. There was some discussion about trying to accommodate single or half day programs and balancing that with ensuring participants get

sufficient on-snow days to improve. The club focus has recently been to improve athletes skills which takes time on snow. Athletes who may be reluctant rise to meet the challenge. They learn from and are pushed by their peers more than adults. Still there is value to a family skiing together, so pricing for the middle ages (U12-14) is set so that the second day is significantly less than one day.

- James asks to consider doing ½ day programmes to keep numbers up as well as looking at [per Rodger] having a girls group to keep interest. Discussion about direction of club and goal – to maintain interest for new members and at same time promote development of Alpine racing.

5. Election of Directors

The following people served as Directors as of the date and time of this Annual General meeting and were thanked for their service. They retire in accordance with 5.5 and 5.10 of the Vernon Ski Club's By-Laws:

1. Aaron Robinson, President
2. Murray Smith, Past President
3. Kurt Lahey, Treasurer
4. Jeremy Guild, Secretary
5. Lauren Carr
6. James Phair
7. Ross Blankley
8. Marty Steele
9. Michael Milne
10. Brady Young
11. Natalie Wilson
12. Rod Williams

The following individuals indicated their willingness to serve in the following capacity until the next Annual General Meeting:

1. Aaron Robinson, President
2. Murray Smith, Past President

Board positions by Acclamation: As noted above.

Vice president – TBA at next Board meeting which will be scheduled for late July.

- 6. Other business that ought to be transacted or brought under consideration by the report of the Directors.**
 - none**
- 7. Meeting adjourned, 8:34pm – Moved: Murray. Second: Jeremy – Carried.**



The Corporation of the City of Vernon

COUNCIL DISCRETIONARY GRANT APPLICATION FORM

IMPORTANT: The deadline for Council Discretionary Grant Applications are semi-annual being April 30 and October 31 each calendar year.

Applications will only be accepted during the intake periods of April 1 - April 30 and October 1 to October 31. Applications must be submitted to the Director of Financial Services no later than 4:00pm on the application deadline (April 30th and October 31st), if City Hall is closed that day, on the next working day that City Hall is open.

Applicants may run the risk of grant funding being depleted if waiting to apply until the October intake deadline.

If grant applications are received after the cut off periods they will be returned to the applicant and must be submitted at the next intake period.

Please note: Incomplete applications will not be considered

ORGANIZATION INFORMATION

NAME OF ORGANIZATION APPLYING FOR COUNCIL DISCRETIONARY GRANT:	Vernon Youth Triathlon Society
CONTACT PERSON:	Nan Kersey
ORGANIZATION MAILING ADDRESS:	[REDACTED]
BUSINESS PHONE:	[REDACTED]
EMAIL ADDRESS:	[REDACTED]
REGISTERED NON PROFIT SOCIETY INCORPORATION NUMBER (required):	

"Personal information contained on this form is collected under the *Freedom of Information and Protection of Privacy Act* and will be used only for the purposes of responding to your request".

City Hall Address: 3400 30th Street, Vernon BC, V1T 5E6
Inquiries: 250-545-1361
Web: www.vernon.ca



The Corporation of the City of Vernon

COUNCIL DISCRETIONARY GRANT APPLICATION FORM

ORGANIZATION GOALS, OBJECTIVES AND ACTIVITIES:

The Vernon Youth Triathlon Society exists to support youth triathlon and multi-sport initiatives in the Greater Vernon area. The society was formed to ensure the sustainability of the annual youth triathlon event and multi-sport and triathlon opportunities for youth in Vernon.

SERVICE PROVIDED TO THE COMMUNITY:

The annual youth triathlon event provides youth with the opportunity to participate in a fun and safe triathlon event. It encourages kids to stay active by swimming, biking and running. We have kept the event low cost to encourage participation. The event is primarily funded through sponsorship so the event gives organizations in our community an opportunity to support kids in sport. We also require over 100 volunteers on race day so Vernon residents have an opportunity to get involved.

A PROFILE AND HISTORY OF THE ORGANIZATION AND ITS ACCOMPLISHMENTS:

The first youth triathlon event in Vernon was held in 2013 and organized by the triathlon community (parents, volunteers, masters triathletes). There were 178 participants and it was a great event. The triathlon has been held every year since and has been growing in popularity along with the sport of triathlon. In 2019, we had 255 registrants, hosted a recreation and competitive stream of events, hosted the provincial junior championship race, the final Triathlon BC Super Series race and a Triathlon Canada youth/junior mixed team relay.

The triathlon event takes a great deal of work to host so to ensure the longevity of the event in 2017 the Vernon Youth Triathlon Society was formed.

PLEASE IDENTIFY THE STEPS YOUR ORGANIZATION HAS TAKEN TO ACQUIRE GRANTS FROM OTHER SOURCES:

In 2017 we received a \$1,500 ViaSport Grant.

We also receive significant community sponsorship and support each year. See notes under the section on sponsorship.

City Hall Address: 3400 30th Street, Vernon BC, V1T 5E6

Inquiries: 250-545-1361

Web: www.vernon.ca



The Corporation of the City of Vernon

COUNCIL DISCRETIONARY GRANT APPLICATION FORM

GRANT REQUEST

(You may wish to provide attachments, please note below where these items can be found.)

<p><u>AMOUNT OF REQUEST:</u></p> <p>\$3,300.00 plus GST = \$3,696.00</p>
<p><u>IN-KIND SERVICES: (please describe and include cost)</u></p> <p>We would like to request the following:</p> <ol style="list-style-type: none"> 1. The City cover the permitting costs for our event. (Park, road & sign permits = \$328.77 for our 2019 event). 2. The City provide us with 2 RCMP officers for the morning of the event. We have had some issues with traffic around our road closures and having an RCMP presence would be a huge help to ensure the safety of our volunteers and participants. 3. The City assist us with some site preparation at Kin Beach prior to our event. If the City could do a clean up (i.e., mow the grass, pick up goose poop, check for needles, sweep out the shelter, etc.) it would really help with the safety and overall experience of the 250 youth running around in bare feet.
<p><u>PURPOSE OF GRANT AND PROPOSED ALLOCATION OF FUNDS:</u></p> <p>For next year's event the City's permit requirements have changed for our venue (Kin Beach) and we will no longer be able to put rebar into the ground to hold up our fencing. The means that we will need to rent fencing which can stand up on its own and the quote which we received for this is \$3,696.00. This a new cost that we will need to incur for next year's event.</p>
<p><u>BENEFITS TO COMMUNITY RESULTING FROM GRANT OR CITY GOALS AND OBJECTIVES THAT WILL BE MET, IF THE GRANT IS APPROVED:</u></p> <p>The new requirements to get a permit for our event at Kin Beach will put a significant financial burden on our organization. If the City could cover the cost of this it would help ensure that we can continue to host the event which encourages kids and families to swim, bike and run in our community and showcases Vernon's ability to host provincially and nationally recognized triathlon events.</p>
<p><u>DEGREE OF COMMUNITY FINANCIAL SUPPORT OR SPONSORSHIP:</u></p> <p>Fifty three percent of our revenue in 2019 came from sponsorship. In addition to this we also received in kind sponsorship from many organizations (ie., hotel rooms, snacks, water, coffee, equipment donation, discounts on products, etc.). A total of 31 organizations provided us with cash or in kind sponsorship for the 2019 event.</p>



The Corporation of the City of Vernon

COUNCIL DISCRETIONARY GRANT APPLICATION FORM

DEGREE OF DEMONSTRATED ECONOMIC DEVELOPMENT, ENVIRONMENTAL STEWARDSHIP OR SOCIAL BENEFIT THAT MAY BE GENERATED BY THE AWARD OF A COUNCIL DISCRETIONARY GRANT:

Economic Impact - In 2019, 98 registrants for the youth triathlon were local, 101 from elsewhere in the Okanagan and 56 were from outside the Okanagan. The event brought 157 youth and their families as visitors to Vernon. In addition, the event encouraged families to support local businesses by purchasing equipment to swim, bike and run.

Social Benefit - encouraging kids to be active promotes physical and mental wellbeing and makes our community stronger.

GRANT QUALIFICATION CHECKLIST (please check all that apply):

- Community Based
- Providing a service which is not provided by any other group or organization within the City or which is provided for in another municipality and used by residents
- Must only submit one application per calendar year
- Grant request is not to cover retroactive funding or to cover a deficit

Note: Organizations do not qualify for the discretionary grant program if they are in receipt of regional funding or are receiving grants or other assistance from the City of Vernon.

GRANT REQUIREMENTS (please attach to your grant application):

- Most Recent Set of Financial Statements
- Minutes of Most Recent Annual General Meeting
- List of Members of the Executive (including positions held, address and contact numbers)

In the case of newly formed groups, a budget and information regarding the organization purpose including list of Board of Directors will be sufficient.

Date

Signature



The Corporation of the City of Vernon

COUNCIL DISCRETIONARY GRANT APPLICATION FORM

DEGREE OF DEMONSTRATED ECONOMIC DEVELOPMENT, ENVIRONMENTAL STEWARDSHIP OR SOCIAL BENEFIT THAT MAY BE GENERATED BY THE AWARD OF A COUNCIL DISCRETIONARY GRANT:

Economic Impact - In 2019, 98 registrants for the youth triathlon were local, 101 from elsewhere in the Okanagan and 58 were from outside the Okanagan. The event brought 157 youth and their families as visitors to Vernon. In addition, the event encouraged families to support local businesses by purchasing equipment to swim, bike and run.

Social Benefit - encouraging kids to be active promotes physical and mental wellbeing and makes our community stronger.

GRANT QUALIFICATION CHECKLIST (please check all that apply):

- Community Based
- Providing a service which is not provided by any other group or organization within the City or which is provided for in another municipality and used by residents
- Must only submit one application per calendar year
- Grant request is not to cover retroactive funding or to cover a deficit

Note: Organizations do not qualify for the discretionary grant program if they are in receipt of regional funding or are receiving grants or other assistance from the City of Vernon.

GRANT REQUIREMENTS (please attach to your grant application):

- Most Recent Set of Financial Statements
- Minutes of Most Recent Annual General Meeting
- List of Members of the Executive (including positions held, address and contact numbers)

In the case of newly formed groups, a budget and information regarding the organization purpose (including list of Board of Directors) will be sufficient.

February 21, 2020 [Signature]
Date Signature

City Hall Address: 3400 30th Street, Vernon BC, V1T 5E6
Inquiries: 250-545-1361
Web: www.vernon.ca

vernon youth triathlon society
 financial report October 4, 2019

	Year To Date	Forecast For Year End	Budget
Revenue			
Race Registrations (CCN)	\$8,176.47	\$8,176.47	\$6,075.00
Sponsorships	\$9,400.00	\$9,400.00	\$8,500.00
Grants	\$0.00	\$0.00	\$0.00
Fundraising	0	0	\$ 1,000.00
Other	\$100.00	\$100.00	\$0.00
Total Revenue	\$17,676.47	\$17,676.47	\$15,575.00
Race Expenses			
Permits	\$328.77	\$328.77	\$350.00
Radio Promotion	\$0.00	\$0.00	\$0.00
Print Promotion	\$738.21	\$738.21	\$650.00
Newspaper Ads	\$428.93	\$428.93	\$750.00
Facebook Ads	\$220.00	\$220.00	
Signage	\$332.64	\$332.64	\$450.00
Sanctioning	\$250.00	\$250.00	\$415.00
Timing	\$2,272.41	\$2,272.41	\$2,200.00
Traffic Control	\$1,306.90	\$1,306.90	\$1,500.00
Food/Beverages	\$76.82	\$76.82	\$0.00
Awards	\$1,389.13	\$1,389.13	\$615.00
Swim Caps	\$455.04	\$455.04	\$0.00
Shirts	\$0.00	\$3,800.00	\$3,800.00
Backpacks	\$0.00	\$550.00	\$550.00
First Aid	\$300.00	\$300.00	\$300.00
Other Supplies	\$378.02	\$378.02	\$500.00
Race Director	\$2,000.00	\$2,000.00	\$2,000.00
Tri BC Officials	\$0.00	\$0.00	\$125.00
Security	\$200.00	\$200.00	\$200.00
Total race expenses	\$10,676.87	\$15,026.87	\$14,405.00

Society Expenses			
Director Tri BC Memerships	\$221.34	\$221.34	\$375.00
Annual Filing	\$40.00	\$40.00	\$40.00
Office Supplies	\$0.00	\$100.00	\$100.00
Prof Development	\$304.71	\$304.71	\$300.00
Bank Charges	\$16.50	\$25.00	\$25.00
Room rental	\$133.41	\$175.00	\$175.00
Total Society Expenses	\$715.96	\$866.05	\$1,015.00
Race and Society Expenses	\$11,392.83	\$15,892.92	\$15,420.00
Balance	\$6,283.64	\$1,783.55	\$155.00

Vernon Youth Triathlon Society

Annual General Meeting

March 7, 2019

Vernon Athletic Park Meeting Room

Present:

Directors - Laura Medcalf, Dana Hudson, Lisa Johnson, Jason McIntyre, Nan Kersey, Todd Benson

Members - Gillian Acton, Mark Wehner, Carey Keith, Anna Vandevoss, Randy Wilson, Ginny Sellers, Warren MacDougal, Warren Campbell

1. Call to Order at 7:01pm
2. Welcome and Introductions
 - a. Introduction of the board of directors & Role definitions
 - i. Jason McIntyre - President (Signing Authority)
 - ii. Lisa Johnson - Vice-President
 - iii. Todd Benson - Treasurer (Signing Authority)
 - iv. Dana Hudson - Secretary
 - v. Nan Kersey - Director at Large
 - vi. Laura Medcalf - Director at Large (Signing Authority)
3. Message from the President
 - a. History of race event
 - b. Culture of Triathlon in the city of Vernon
 - c. Formalization of Society
 - d. Support for Race Director
 - e. Development of event
4. Treasurer's Report (Todd)
 - a. See attached for written report
 - b. Introduction of role
 - c. Ended fiscal year with more money in the bank then when we started

- d. Some issues with accounting that need to be examined
 - e. \$6, 238.38 in race revenue in 2018
 - f. \$8, 250.00 in sponsorships in 2018
 - g. Treasurer's report made available for attendees
 - h. Goal is to have 1 year of race expenses in the bank at all times
5. Race Director's Report (Laura)
- a. History of race event and acknowledgement of key players
 - b. Presentation of slide show
 - c. Explanation of LTAD pathway
 - d. Outline of series championships, provincial championships, and Western Canadian Championships - retention of athletes and increase relevance in local/provincial/national market
 - e. Opportunities for branding, community engagement and leading industry
 - f. Updates:
 - i. Event date - September 8 2019
 - ii. Triathlon Canada National Development Tier 2 Race
 - iii. Mandatory Project 2024 Team Event
 - iv. MTR - Mixed Team Relay
 - v. Open Water Swim Event June 15
 - vi. 2019 Lead Team (Race Event) Introduction and role definitions
 - vii. 2019 Race Event timelines and dates
6. Volunteer Coordinator Report - Nan
- a. Discussion of challenges and successes in past with communication
 - b. Discussion of volunteer positions - diversity
 - c. Recruitment starting soon
7. Introduction of Gillian Acton as new treasurer
- a. Thank you to Todd Benson for all of his hard work over the past year
 - b. Todd Benson and Virginia Sellers will be removed from our bank account as signing authority and Gillian Acton will be added to our account with signing authority.
8. Questions from the floor
- a. None

9. Motion to adjourn at 7:41pm

- a. Motion - Todd
- b. Second - Laura
- c. Carried - Unanimous



FINANCIAL REPORT BY DIVISION - CONSOLIDATED

September 30, 2019

Division/Department	Amended Net Budget	YTD Actual Net Results	Available Budget
OPERATING RESULTS ONLY			
Administration	\$ (890,120)	\$ (635,214)	\$ (254,906)
Community, Infrastructure & Development	(2,630,136)	(1,883,104)	(747,032)
Public Transit	(1,945,665)	(763,172)	(1,182,493)
Corporate Services	(2,453,603)	(2,135,399)	(318,204)
RCMP Municipal Support	(1,755,625)	(1,436,785)	(318,840)
Bylaw Compliance & Community Safety	(122,659)	(49,984)	(72,675)
Financial Services	(535,455)	199,681	(735,136)
Grants	(180,500)	(174,606)	(5,894)
Fiscal Services - General	2,855,819	6,573,778	(3,717,959)
Fire Rescue Services	(5,874,482)	(4,470,052)	(1,404,430)
Human Resources	(1,569,180)	(826,272)	(742,908)
Operations	511,700	533,211	(21,511)
Airport	(107,937)	(6,643)	(101,294)
Public Works	(5,686,150)	(4,334,932)	(1,351,218)
Parks Maintenance	(2,099,676)	(1,677,361)	(422,315)
Fleet Operation	-	(110,584)	110,584
Facilities	(1,477,250)	(1,207,524)	(269,726)
Storm Drainage	(297,142)	(197,039)	(100,103)
Water Contract Services	-	(1,104,071)	1,104,071
Sewer (including Fiscal Services)	-	(1,157,033)	1,157,033
RCMP Contract Services	(9,446,088)	(4,193,310)	(5,252,778)
Recreation Services	(2,439,789)	(1,496,299)	(943,490)
NET OPERATING RESULTS	\$ (36,143,938)	\$ (20,552,714)	\$ (15,591,224)
NET INFRASTRUCTURE PROJECTS	(4,396,870)	(2,569,756)	(1,827,114)
NET OPERATING & PROJECTS RESULTS	\$ (40,540,808)	\$ (23,122,470)	\$ (17,418,338)

REVENUE	Amended Budget	YTD Actual	Available Budget	YTD % Spent	Variance Explanations & Notes
					<i>Q3 range should be 60% to 75%</i>
1% Utility, Local Area Service & Grants In Lieu	\$ 2,038,863	\$ 2,067,966	\$ (29,103)	101.4%	Taxation revenues collected midway through year. Grants in Lieu collected higher than budgeted.
Sales of Services	15,532,527	10,824,743	4,707,784	69.7%	Within acceptable range.
Sanitary Sewer Fees	9,661,056	4,729,788	4,931,268	49.0%	3rd quarter sewer fees billed in October.
Government Transfers	14,879,445	8,727,264	6,152,181	58.7%	Additional Gas Tax grant received offset by multi-million dollar capital grants not received (30 St & Lakeview wading pool).
Services Provided to Other Governments	3,052,873	2,217,675	835,198	72.6%	Within acceptable range.
Fiscal Services	9,548,139	2,410,625	7,137,514	25.2%	McMechon Reservoir land sale proceeds not received.
Transfers From Reserves	41,331,348	1,703,892	39,627,456	4.1%	Reserve funding for one-time projects are predominately recorded at year-end.
Contribution From Developers	5,759,097	-	5,759,097	0.0%	Developer Contributed Capital (DCC) related to one-time project funding are recorded at year-end.
Natural Gas System	2,316,000	916,102	1,399,898	39.6%	Annual Fortis BC franchise fee (\$442K) and second bi-annual operating payment (\$916K) will be received in late Fall.
Total Revenue	104,119,348	33,598,054	70,521,294	32.3%	
EXPENSES					
Salaries, Wages & Benefits	31,959,048	23,451,878	8,507,170	73.4%	Within acceptable range.
Supplies, Materials & Others	10,258,973	6,290,867	3,968,106	61.3%	Within acceptable range.
Contracted Services	25,353,028	19,445,517	5,907,511	76.7%	Contract costs for projects recorded here but budgeted in last row below. With Infrastructure projects removed, Contracted Services is 60.2% spent.
Fiscal Services	2,980,661	1,652,835	1,327,826	55.5%	Debt payments semi-annual. Second payments made in October and December.
Utilities, Communication & Insurance	4,379,945	2,819,984	1,559,961	64.4%	Within acceptable range.
Cost of Goods Sold	685,707	749,068	(63,361)	109.2%	Airport fuel purchases higher than budgeted.
Transfers to Reserves	17,117,338	1,674,161	15,443,177	9.8%	Most transfers to reserves are recorded at year end.
Internal Charges	482,052	636,213	(154,161)	132.0%	Common Service Allocations between General and Sewer funds already booked. Some fleet charges related to one-time projects recorded here but budgets in row below.
Project Budgets Only	51,443,404	-	51,443,404	0.0%	All actual costs for projects are recorded to the appropriate object codes.
Total Expenses	144,660,156	56,720,524	87,939,632	39.2%	
Overall Results	\$ (40,540,808)	\$ (23,122,470)	\$ (17,418,338)	57.0%	Note: 2019 Total Tax Requirement = \$40,540,808

Division/Department	Amended Budget	Year-to-Date Actuals	Difference from Budget*	% Diff	Variance Explanations & Notes
					<i>Q3 range should be 60% to 75%</i>
Administration	\$ 8,432	\$ -	\$ 8,432	0.0%	Project funding recorded at year end.
Community, Infrastructure & Development	4,953,165	2,573,413	2,379,752	52.0%	Reserve funding for projects not recorded until year-end.
Public Transit	3,520,215	1,981,935	1,538,280	56.3%	Third quarter transit revenues not received.
Corporate Services	8,013,042	328,110	7,684,932	4.1%	McMechan Reservoir land sale proceeds not received.
RCMP Municipal Support	621,467	194,275	427,192	31.3%	RCMP Detachment building rental revenue, support services and Keep of Prisoner recoveries below budget.
Bylaw Compliance & Community Safety	1,551,209	1,189,184	362,025	76.7%	Annual internal recovery from Parks fully recorded related to parking lot coin collection and inspection.
Financial Services	2,023,578	2,012,704	10,874	99.5%	Higher than budgeted revenues received related to penalties on taxes and return on short term investments.
Grants	102,014	75,296	26,718	73.8%	Within acceptable range.
Fiscal Services - General	9,363,178	7,628,953	1,734,225	81.5%	Unbudgeted additional Federal Gas Tax grant received.
Fire Rescue Services	2,972,783	314,387	2,658,396	10.6%	Reserve funding for projects not recorded until year-end.
Human Resources	414,018	401,894	12,124	97.1%	Reserve funding for temporary talent acquisition relief and final MSP payment already recorded.
Operations	262,157	155,739	106,418	59.4%	GVW Admin fee not received for quarter 3.
Airport	1,017,998	1,097,959	(79,961)	107.9%	Hanger lease revenue received equals annual budget with fuel sales surpassing the annual budget.
Public Works	3,716,757	1,852,859	1,863,898	49.9%	Solid Waste and Recycling fees not billed for quarter 3.
Parks Maintenance	1,054,778	136,491	918,287	12.9%	Reserve funding for one-time Parks projects not recorded until year-end. Balance represents Park booking admin fees and cost recoveries.
Fleet Operation	1,225,224	-	1,225,224	0.0%	Reserve funding for fleet replacements recorded at year-end.
Facilities	556,311	25,261	531,050	4.5%	Reserve funding for one-time facilities projects recorded at year-end.
Storm Drainage	45,000	59,095	(14,095)	131.3%	Storm service connection fees higher than budgeted.
Water Contract Services	3,143,292	1,456,681	1,686,611	46.3%	Contract revenues for water distribution and maintenance not billed for quarter 3.
Sewer (including Fiscal Services)	25,062,010	5,304,915	19,757,095	21.2%	Sewer fees and charges not billed for quarter 3. Reserve funding for one-time sewer projects recorded at year-end.
RCMP Contract Services	489,790	475,490	14,300	97.1%	Traffic Fine Revenue grant received in June.
Recreation Services	5,421,461	3,874,278	1,547,183	71.5%	Within acceptable range.
TOTAL OPERATING REVENUES	\$ 75,537,879	\$ 31,138,919	\$ 44,398,960	41.2%	

* Difference from budget is calculated as "Budget" less "YTD Actuals"

Division/Department	Variance Explanations & Notes				
	Amended Budget	Year-to-Date Actuals	Difference from Budget*	% Diff	Q3 range should be 60% to 75%
Administration	\$ 898,552	\$ 635,214	\$ 263,338	70.7%	Within acceptable range.
Community, Infrastructure & Development	7,583,301	4,456,517	3,126,784	58.8%	One-time projects not completed and include Silver Star Rd MUP purchase, Flood Plain mapping, Drainage Plan OK Lake, Climate Action planning and Village Green transit exchange contribution.
Public Transit	5,465,880	2,745,108	2,720,772	50.2%	Transit expenses for quarter 3 not invoiced.
Corporate Services	10,466,645	2,463,509	8,003,136	23.5%	McMechon Reservoir land sale proceeds not received.
RCMP Municipal Support	2,377,092	1,631,059	746,033	68.6%	Within acceptable range.
Bylaw Compliance & Community Safety	1,673,868	1,239,169	434,699	74.0%	Within acceptable range.
Financial Services	2,559,033	1,813,023	746,010	70.8%	Within acceptable range.
Fiscal Services - General	6,507,359	1,055,175	5,452,184	16.2%	Grant monies received are transferred to reserves at year-end.
Grants	282,514	249,902	32,612	88.5%	Grants are paid intermittently throughout the year.
Fire & Rescue	8,847,265	4,784,439	4,062,826	54.1%	One-time projects related to Ladder Truck and Fire Engine purchases not made in quarter 3.
Human Resources	1,983,198	1,228,165	755,033	61.9%	Within acceptable range.
Operations	(249,543)	(377,472)	127,929	151.3%	Common Service Allocation from Sewer fund fully recorded.
Airport	1,125,935	1,104,602	21,333	98.1%	Higher than budgeted purchases of aviation fuel. Corresponds with higher than budgeted fuel sales.
Public Works	9,402,907	6,187,791	3,215,116	65.8%	Within acceptable range.
Parks Maintenance	3,154,454	1,813,853	1,340,601	57.5%	One-time projects related to Turtle Mtn boulevard and Marshall Field fencing not started. Kin Race Track demolition significantly underbudget.
Fleet Operation	1,225,224	110,584	1,114,640	9.0%	Fleet operations have resulted in realized net recovery and only approximately a third of the planned fleet replacements have been made.
Facilities	2,033,561	1,232,785	800,776	60.6%	Within acceptable range.
Storm Drainage	342,142	256,134	86,008	74.9%	Within acceptable range.
Water Contract Services	3,143,292	2,560,752	582,540	81.5%	Unbudgeted expenses related to water service installations, motor vehicle accidents, meter installation and replacements. All expenses incurred will be recovered from third parties.
Sewer (including Fiscal Services)	25,062,010	6,461,948	18,600,062	25.8%	Sanitary sewer one-time projects not started. Projects include Septage land purchase and sale, pre-treatment facility and chemical dosing construction.
RCMP Contract Services	9,935,878	4,668,800	5,267,078	47.0%	Third quarter invoice for contract RCMP services received October.
Recreation Services	7,861,250	5,370,577	2,490,673	68.3%	Within acceptable range.
TOTAL OPERATING EXPENSES	\$ 111,681,817	\$ 51,691,633	\$ 59,990,184	46.3%	

* Difference from budget is calculated as "Budget" less "YTD Actuals"